



Company Policies & Information

Ordering

All moulding are priced by the linear foot - For customized lengths of any of our mouldings, we recommend putting your orders through our order form. One of our members will reach out to you to discuss your order and what we can supply. Even though we always do our best to match our customers' expectations, we always advise not to order exact amounts due to imperfections on lumber.

i.e an 8ft board could potentially be as short as 7.5 feet due to splits in the lumber ends.

Set-Up Charges

Set-up pricing revolves around quantity ordered and volume purchased per profile of each species. Any high volume, starting at 250' per profile ordered leads to bulk production that eliminates the set up fee. We encourage customers who are doing bulk orders to contact us so that we can adjust the surcharges accordingly.

Custom Mouldings

With many pre-designed options to pick from, we often are in a position to accommodate your next project. At times there maybe a profile needed that we have not yet used but we are flexible and can accommodate all of our customer's needs. All we need in this case is a sample board or a drawing of the molding and we'll produce custom tooling for your molding. A one-time tooling fee may be charged but this may be voided depending on the volume ordered. All custom tooling is manufactured in house and therefore helps us keep the tooling cost low and efficient. Unlike the standard market timing, we can do custom work in as short as one day. (Refer to our quotes for lead times).

Production Time

Our delivery times revolve around key factors such as; wood species availability, standard vs custom molding profiles, and more. Depending on the moulding specifications, the lead time can vary but still be delivered within a reasonable time period. Our Oak, Maple and Paint Grade moldings take an estimated 4 working days to produce while all other profiles can be processed within the same time period as cabinet doors where customers have the option to choose the lead time. A realistic lead time is best given during ordering and we advise our customers to always check the lead times per individual order.

Drawings

We have done our best to make drawings to scale, but we cannot guarantee them to be exact.

All Terms and Conditions are subject to www.rbmillwork.com. The catalogue is intended to be used as a guide and will be subject to revisions/corrections as we deem necessary. We reserve the right to change without notice.

Wood Types

Hard Maple	Clear Pine	Walnut - Clean no Knots
Soft Maple	Knotty Pine	Fir
Brown Maple (Character Maple)	Birch	Knotty Fir
Red Oak Flat Cut - Normal	Ash	Poplar - Paint Grade
Red Oak - Rift Cut	Elm	Aspen
White Oak Flat Cut - Normal	Calico Hickory - Clean no Knots	Knotty Alder
Whit Oak Rift Cut	Rustic Hickory	Clear Alder
Cherry	Rustic Walnut	

Don't see the wood type you're looking for? Contact us!

Measurements

Please refer to the following diagram to interpret moulding measurements stated on the quote/confirmation.

Our standard moulding capabilities is from 20mm wide to 230mm (y) and from 8mm thickness - 160mm (z)

Contact us if you need oversized/undersized mouldings or parts.

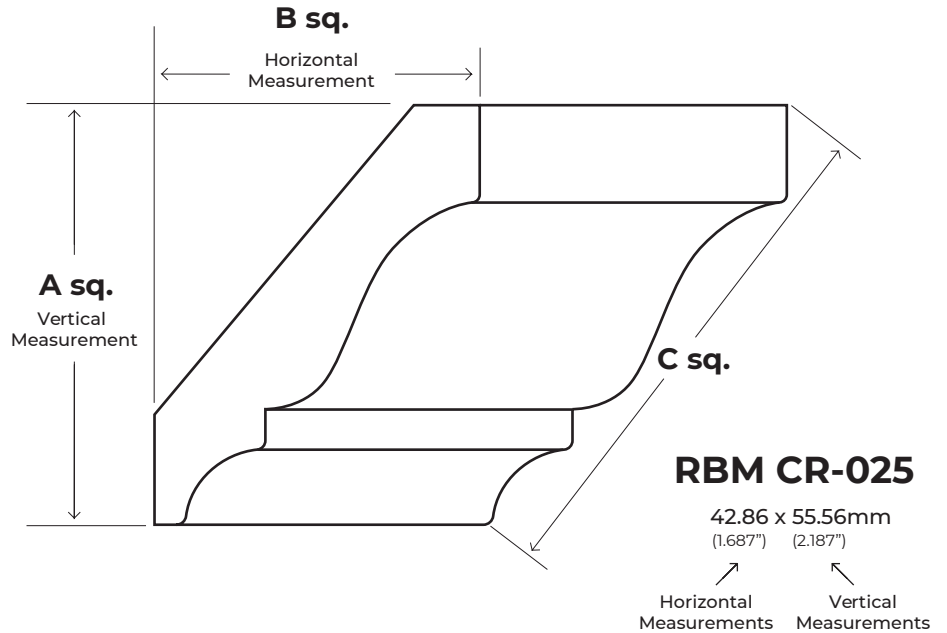

How to figure out the square root on a crown moulding

You have to go $A^2 + B^2 = C^2$.

If a crown is 2.312 up (Vertical) and 2.79 across (Horizontal)

$$2.79 \times 2.79 = 7.78$$

$$2.312 \times 2.312 = 5.345$$

$$7.78 + 5.345 = 13.125$$

Press the square root button ($\sqrt{\quad}$) on the calculator = **3.62"**

Remember

When doing the square root calculation you cannot go $2.312 \times 2 = 4.624$, you have to go $2.312 \times 2.312 = 5.345$

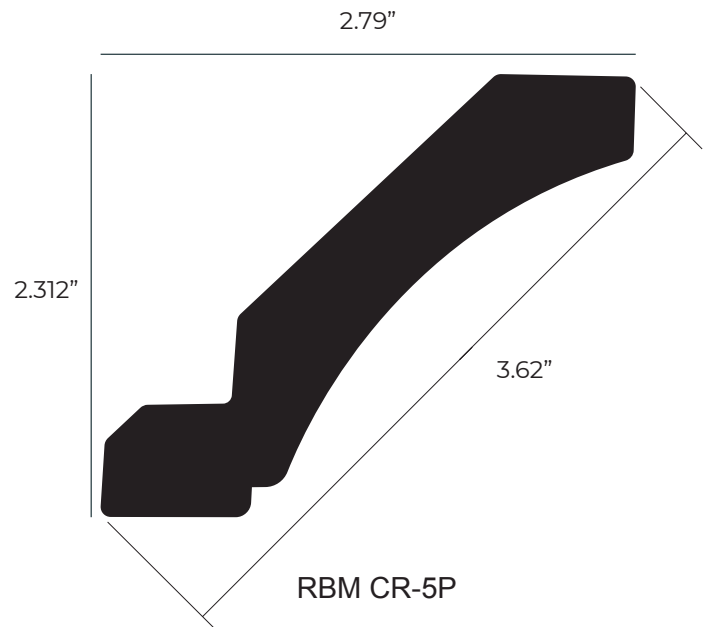

Moulding Index

Code	Page	Code	Page	Code	Page	Code	Page	Code	Page
MOST POPULAR									
RBM CR-1P	7	RBM CR-021	12	RBM CR-071	19	RBM NS-1	33	RBM BA-43	45
RBM CR-5P	7	RBM CR-022	12	RBM CR-072	19	RBM NS-2	33	RBM BA-44	45
RBM CR-6P	7	RBM CR-023	13	RBM CR-073	19	RBM NS-3	33	RBM BA-45	45
RBM CR-7P	7	RBM CR-024	13	RBM CR-074	20	RBM NS-4	33	RBM BA-46	45
RBM CR-8P	7	RBM CR-025	13	RBM CR-075	20	BASEBOARDS		RBM BA-47	46
RBM CR-9P	8	RBM CR-026	13	RBM CR-076	20	Flat Face	34	RBM BA-48	46
RBM CR-10P	8	RBM CR-027	13	RBM CR-077	20	Popular Sizes	35	RBM BA-49	46
RBM CR-11P	8	RBM CR-028	13	RBM CR-078	20	Edge Options	37	RBM BA-50	46
RBM CR-12P	8	RBM CR-029	13	RBM CR-079	21	RBM BA-1	38	RBM BA-51	46
RBM CR-13P	8	RBM CR-030	13	RBM CR-080	21	RBM BA-2	38	RBM BA-52	47
RBM CR-14P	8	RBM CR-031	13	RBM CR-081	21	RBM BA-3	38	RBM BA-53	47
RBM CR-15P	9	RBM CR-032	13	RBM CR-082	21	RBM BA-4	38	RBM BA-54	47
RBM CR-16P	9	RBM CR-033	13	RBM CR-083	22	RBM BA-5	38	RBM BA-55	47
RBM CR-17P	9	RBM CR-034	14	RBM CR-084	22	RBM BA-6	38	RBM BA-56	47
RBM CR-18P	9	RBM CR-035	14	RBM CR-085	22	RBM BA-7	38	RBM BA-57	48
RBM CR-19P	9	RBM CR-036	14	RBM CR-086	22	RBM BA-8	38	RBM BA-58	48
RBM CR-20P	9	RBM CR-037	14	RBM CR-087	23	RBM BA-9	38	RBM BA-59	48
RBM CR-21P	9	RBM CR-038	14	RBM CR-088	23	RBM BA-10	38	BANDS	
RBM CR-22P	9	RBM CR-039	14	RBM CR-089	23	RBM BA-11	39	RBM BAND-01	49
RBM CR-23P	10	RBM CR-040	14	RBM CR-090	23	RBM BA-12	39	RBM BAND-02	49
RBM CR-24P	10	RBM CR-041	14	RBM CR-091	24	RBM BA-13	39	RBM BAND-03	49
RBM CR-25P	10	RBM CR-042	14	RBM CR-092	24	RBM BA-14	39	RBM BAND-04	49
RBM CR-27P	10	RBM CR-043	15	RBM CR-093	24	RBM BA-15	39	RBM BAND-05	49
RBM HR-150	10	RBM CR-044	15	RBM CR-094	24	RBM BA-16	39	RBM BAND-06	49
RBM HR-1P	10	RBM CR-045	15	RBM CR-095	25	RBM BA-17	40	RBM BAND-07	49
RBM HR-45	10	RBM CR-046	15	RBM CR-096	25	RBM BA-18	40	RBM BAND-08	49
RBM HR-1	10	RBM CR-047	15	RBM CR-097	25	RBM BA-19	40	RBM BAND-09	49
RBM HR-3	10	RBM CR-048	15	RBM CR-098	25	RBM BA-20	40	RBM BAND-10	49
CROWNS									
RBM CR-001	11	RBM CR-049	15	RBM CR-099	26	RBM BA-21	40	RBM BAND-11	49
RBM CR-002	11	RBM CR-050	16	RBM CR-100	26	RBM BA-22	41	RBM BAND-12	49
RBM CR-003	11	RBM CR-051	16	RBM CR-101	26	RBM BA-23	41	RBM BAND-13	49
RBM CR-004	11	RBM CR-052	16	RBM CR-102	26	RBM BA-24	41	RBM BAND-14	49
RBM CR-005	11	RBM CR-053	16	RBM CR-103	27	RBM BA-25	41	RBM BAND-15	50
RBM CR-006	11	RBM CR-054	16	RBM CR-104	27	RBM BA-26	41	RBM BAND-16	50
RBM CR-007	11	RBM CR-055	16	RBM CR-105	27	RBM BA-27	42	RBM BAND-17	50
RBM CR-008	11	RBM CR-056	17	RBM CR-106	27	RBM BA-28	42	RBM BAND-18	50
RBM CR-009	11	RBM CR-057	17	RBM CR-107	28	RBM BA-29	42	RBM BAND-19	50
RBM CR-010	11	RBM CR-058	17	RBM CR-108	28	RBM BA-30	42	RBM BAND-20	50
RBM CR-011	11	RBM CR-059	17	RBM CR-109	28	RBM BA-31	42	RBM BAND-21	50
RBM CR-012	11	RBM CR-060	17	RBM CR-110	28	RBM BA-32	43	RBM BAND-22	50
RBM CR-013	12	RBM CR-061	17	RBM CR-111	29	RBM BA-33	43	RBM BAND-23	50
RBM CR-014	12	RBM CR-062	18	RBM CR-112	29	RBM BA-34	43	RBM BAND-24	50
RBM CR-015	12	RBM CR-063	18	RBM CR-113	29	RBM BA-35	43	RBM BAND-25	50
RBM CR-016	12	RBM CR-064	18	RBM CR-114	30	RBM BA-36	43	RBM BAND-26	50
RBM CR-017	12	RBM CR-065	18	RBM CR-115	30	RBM BA-37	44	RBM BAND-27	51
RBM CR-018	12	RBM CR-066	18	RBM CR-116	31	RBM BA-38	44	RBM BAND-28	51
RBM CR-019	12	RBM CR-067	18	RBM CR-117	31	RBM BA-39	44	RBM BAND-29	51
RBM CR-020	12	RBM CR-068	19	RBM CR-118	32	RBM BA-40	44	RBM BAND-30	51
		RBM CR-069	19	RBM CR-119	32	RBM BA-41	44	RBM BAND-31	51
		RBM CR-070	19	NAILING STRIPS		RBM BA-42	45	RBM BAND-32	51

Moulding Index

Code	Page	Code	Page	Code	Page	Code	Page
RBM BAND-33	51	RBM CAS225-017	55	RBM CAS325-007	59	RBM CHR175-003	67
RBM BAND-34	51	RBM CAS225-018	55	RBM CAS350-001	59	RBM CHR175-004	67
RBM BAND-35	51	RBM CAS225-019	55	RBM CAS350-002	59	RBM CHR200-001	67
CAPS		RBM CAS225-020	55	RBM CAS350-003	59	RBM CHR225-001	67
RBM CAP-01	52	RBM CAS225-021	55	RBM CAS350-004	59	RBM CHR225-002	67
RBM CAP-02	52	RBM CAS250-001	55	RBM CAS350-005	59	RBM CHR225-003	67
RBM CAP-03	52	RBM CAS250-002	55	RBM CAS350-006	59	RBM CHR250-001	67
RBM CAP-04	52	RBM CAS250-003	55	RBM CAS350-007	60	RBM CHR250-002	67
RBM CAP-05	52	RBM CAS250-004	55	RBM CAS350-008	60	RBM CHR250-003	67
RBM CAP-06	52	RBM CAS250-005	55	RBM CAS350-009	60	RBM CHR275-001	68
RBM CAP-07	52	RBM CAS250-006	55	RBM CAS350-010	60	RBM CHR275-002	68
RBM CAP-08	52	RBM CAS250-007	56	RBM CAS350-011	60	RBM CHR275-003	68
RBM CAP-09	52	RBM CAS250-008	56	RBM CAS350-012	60	RBM CHR275-004	68
RBM CAP-10	52	RBM CAS250-009	56	RBM CAS350-013	61	RBM CHR275-005	68
RBM CAP-11	52	RBM CAS250-010	56	RBM CAS350-014	61	RBM CHR300-001	68
RBM CAP-12	52	RBM CAS250-011	56	RBM CAS350-015	61	RBM CHR300-002	68
RBM CAP-13	52	RBM CAS250-012	56	RBM CAS350-016	61	RBM CHR300-003	68
RBM CAP-14	52	RBM CAS250-013	56	RBM CAS350-017	61	RBM CHR300-004	68
RBM CAP-15	52	RBM CAS250-014	56	RBM CAS350-018	61	RBM CHR300-005	68
RBM CAP-16	53	RBM CAS250-015	56	RBM CAS375-001	62	RBM CHR300-006	69
RBM CAP-17	53	RBM CAS250-016	56	RBM CAS375-002	62	RBM CHR300-007	69
RBM CAP-18	53	RBM CAS275-001	56	RBM CAS375-003	62	RBM CHR300-008	69
RBM CAP-19	53	RBM CAS275-002	56	RBM CAS375-004	62	RBM CHR300-009	69
RBM CAP-20	53	RBM CAS275-003	57	RBM CAS400-001	62	RBM CHR300-010	69
RBM CAP-21	53	RBM CAS275-004	57	RBM CAS400-002	62	RBM CHR300-011	69
RBM CAP-22	53	RBM CAS275-005	57	RBM CAS400-003	63	RBM CHR300-012	69
RBM CAP-23	53	RBM CAS275-006	57	RBM CAS400-004	63	RBM CHR300-013	69
RBM CAP-24	53	RBM CAS275-007	57	RBM CAS400-005	63	RBM CHR300-014	69
RBM CAP-25	53	RBM CAS275-008	57	RBM CAS400-006	63	RBM CHR300-015	69
RBM CAP-26	53	RBM CAS275-009	57	RBM CAS400-007	63	RBM CHR300-016	69
RBM CAP-27	53	RBM CAS275-010	57	RBM CAS425-001	63	RBM CHR325-001	70
RBM CAP-28	53	RBM CAS275-011	57	RBM CAS425-002	64	RBM CHR325-002	70
RBM CAP-29	53	RBM CAS300-001	57	RBM CAS425-003	64	RBM CHR325-003	70
RBM CAP-30	53	RBM CAS300-002	57	RBM CAS425-004	64	RBM CHR325-004	70
CASINGS		RBM CAS300-003	57	RBM CAS425-005	64	RBM CHR325-005	70
RBM CAS225-001	54	RBM CAS300-004	58	RBM CAS425-006	64	RBM CHR325-006	70
RBM CAS225-002	54	RBM CAS300-005	58	RBM CAS425-007	65	RBM CHR325-007	70
RBM CAS225-003	54	RBM CAS300-006	58	RBM CAS425-008	65	RBM CHR350-001	70
RBM CAS225-004	54	RBM CAS300-007	58	RBM CAS450-001	65	RBM CHR350-002	70
RBM CAS225-005	54	RBM CAS300-008	58	RBM CAS450-002	65	RBM CHR350-003	70
RBM CAS225-006	54	RBM CAS300-009	58	RBM CAS450-003	65	RBM CHR350-004	71
RBM CAS225-007	54	RBM CAS300-010	58	RBM CAS450-004	65	RBM CHR375-001	71
RBM CAS225-008	54	RBM CAS300-011	58	RBM CAS450-005	66	RBM CHR400-001	71
RBM CAS225-009	54	RBM CAS300-012	58	RBM CAS475-001	66	RBM CHR400-002	71
RBM CAS225-010	54	RBM CAS300-013	58	RBM CAS500-001	66	RBM CHR400-003	71
RBM CAS225-011	54	RBM CAS325-001	58	RBM CAS500-002	66	RBM CHR400-004	71
RBM CAS225-012	54	RBM CAS325-002	58	RBM CAS550-001	66	RBM CHR400-005	72
RBM CAS225-013	54	RBM CAS325-003	59	RBM CAS550-002	66	RBM CHR400-006	72
RBM CAS225-014	54	RBM CAS325-004	59	CHAIR RAILS		RBM CHR425-001	72
RBM CAS225-015	55	RBM CAS325-005	59	RBM CHR175-001	67	RBM CHR450-001	72
RBM CAS225-016	55	RBM CAS325-006	59	RBM CHR175-002	67	RBM CHR450-002	72

Moulding Index

Code	Page	Code	Page	Code	Page
RBM CHR475-001	72	RBM HR-1	79	LIGHT RAIL MOULDING	
RBM CHR500-001	73	RBM HR-2	79	SQUARE	88
RBM CHR500-002	73	RBM HR-3	79	1/4 ROUND	88
RBM CHR525-001	73	RBM HR-4	79	COVE	88
RBM CHR525-002	73	RBM HR-5	79	BEVEL	88
RBM CHR550-001	73	RBM HR-6	79	EASED	88
APPLIED FINISHED		RBM HR-7	79	RL	88
CORNERS		RBM HR-8	79	1/8 ROUNG	88
RBM AFCR-34	74	RBM HR-9	80	DR	88
RBM AFCR-78	74	RBM HR-10	80	CR	88
RBM AFCR-11	74	RBM HR-11	80	RDL	88
RBM AFCR-118	74	RBM HR-12	80	SRL	88
RBM AFCR-112	74	RBM HR-13	80	1/16 ROUND	88
RBM AFCR-134	74	RBM HR-14	80	OGEE	88
RBM AFCR-45D-1-1	74	RBM HR-15	81	DB	88
RBM AFCR-45D.75-.75	74	RBM HR-16	81	S4S	89
RBM AFICR-12	74	RBM HR-17	81	MOULDING	90
RBM AFICR-9	75	RBM HR-18	81	KNIVES	
RBM AFCRR-10	75	RBM HR-19	81	ORDER FORM	91
RBM AFCRR-13	75	RBM HR-20	81		
RBM AFCRR-16	75	RBM HR-21	82		
RBM AFCRR-18	75	RBM HR-22	82		
RBM AFCRD-16	75	RBM HR-23	82		
SCRIBE		RBM HR-24	82		
RBM S-1	76	RBM HR-25	82		
RBM S-2	76	RBM HR-26	82		
RBM S-3	76	RBM HR-27	83		
RBM S-4	76	RBM HR-28	83		
RBM S-5	76	RBM HR-29	83		
RBM S-6	76	RBM HR-30	83		
RBM S-7	76	RBM HR-31	83		
RBM S-8	76	RBM HR-32	83		
RBM S-9	76	RBM HR-33	84		
RBM S-10	76	RBM HR-34	84		
RBM S-11	76	RBM HR-35	84		
RBM S-12	76	RBM HR-36	84		
RBM S-13	76	RBM HR-37	84		
RBM S-14	76	RBM HR-38	84		
RBM S-15	76	RBM HR-39	85		
TONGUE & GROOVE		RBM HR-40	85		
RBM T&G-214	77	RBM HR-41	85		
RBM T&G-212	77	RBM HR-42	85		
RBM T&G-234	77	RBM HR-43	86		
RBM T&G-35	77	RBM HR-44	86		
RBM T&G-4	77	HALF CIRCLE			
RBM T&G-45	77	RBM HC-1	87		
RBM T&G-525	77	RBM HC-2	87		
RAILS		RBM HC-3	87		
RBM HR-150	78	RBM HC-4	87		
RBM HR-1P	78	RBM HC-5	87		
RBM HR-45	79	RBM HC-6	87		

Crowns

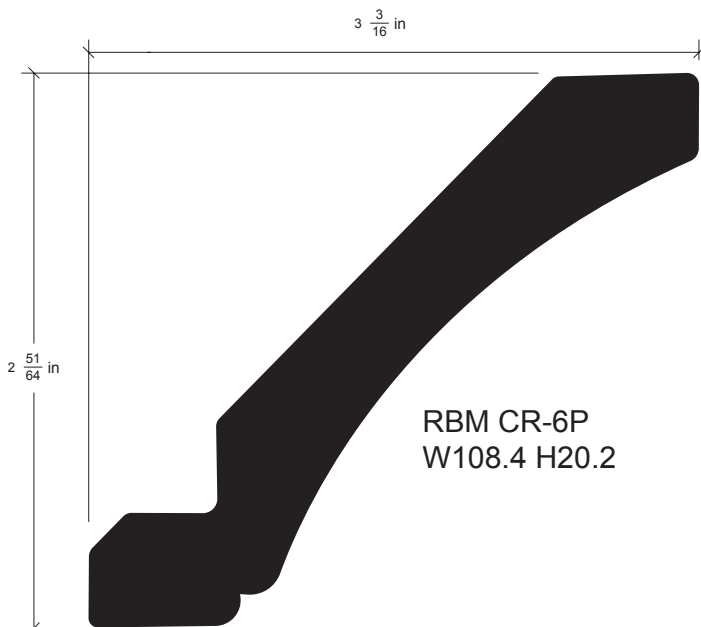
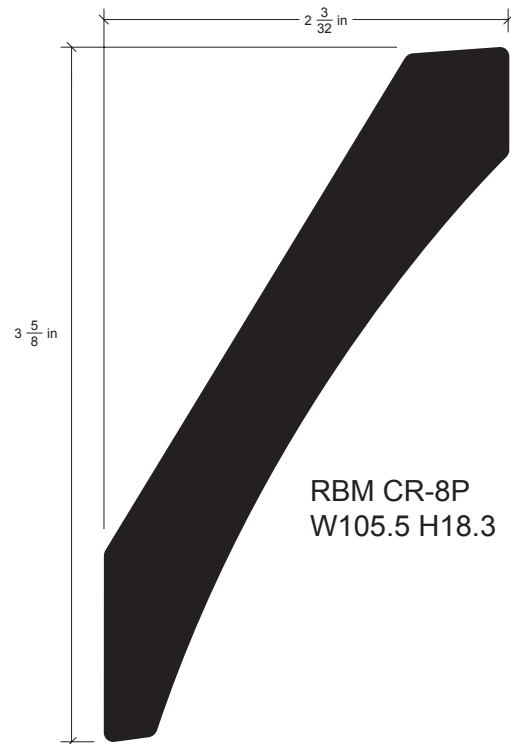
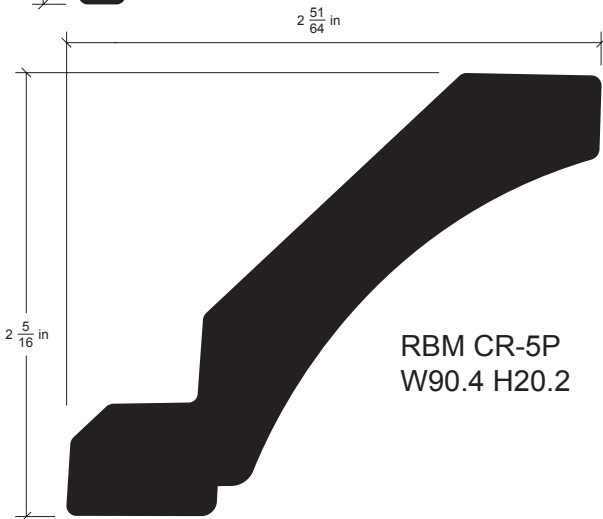
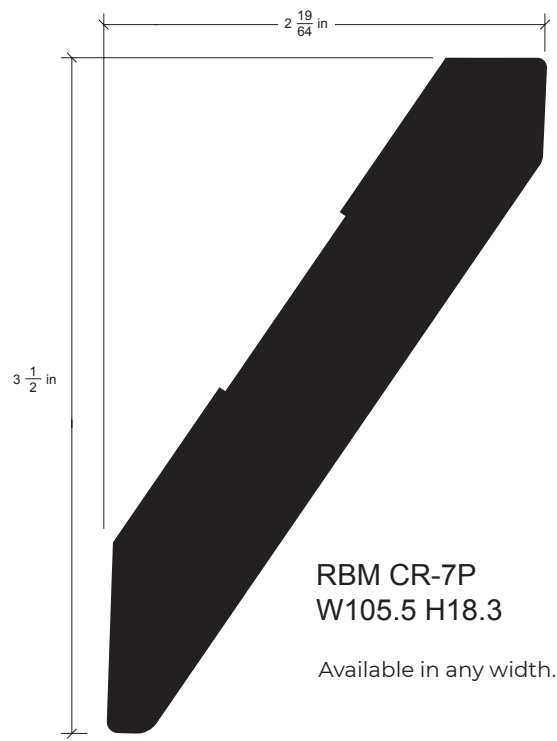
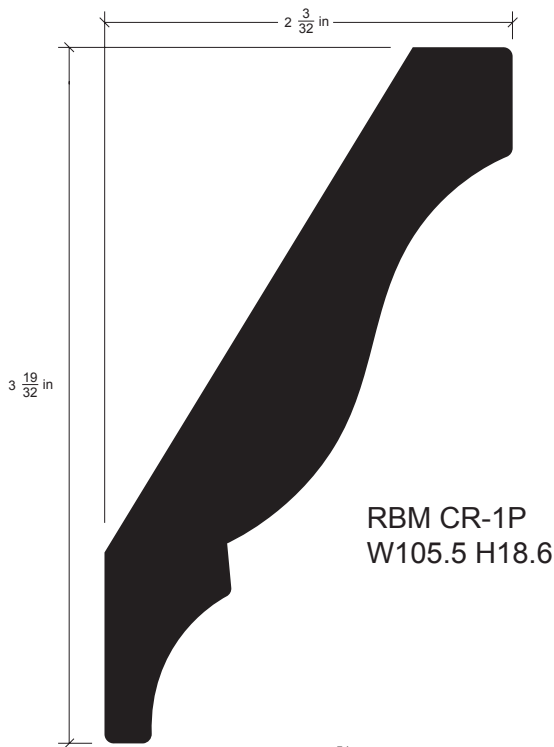

Most Popular

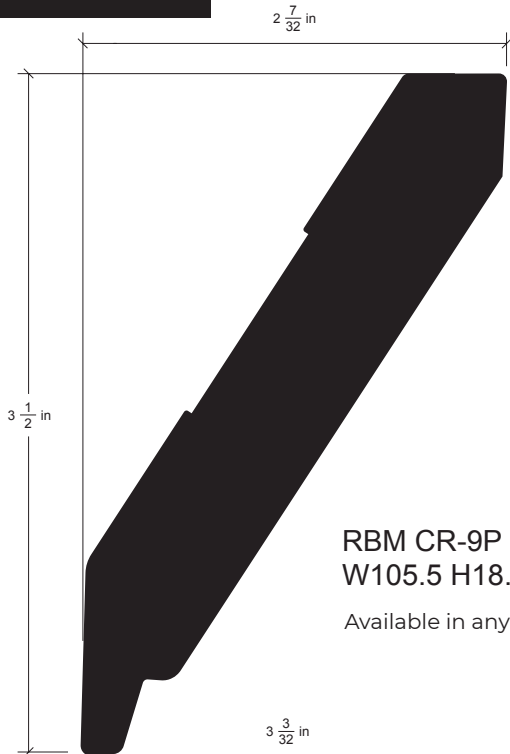

RBM CR-9P
W105.5 H18.3

Available in any width.

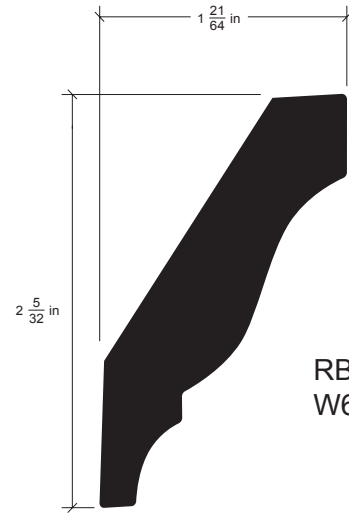

RBM CR-12P
W63.8 H14.2

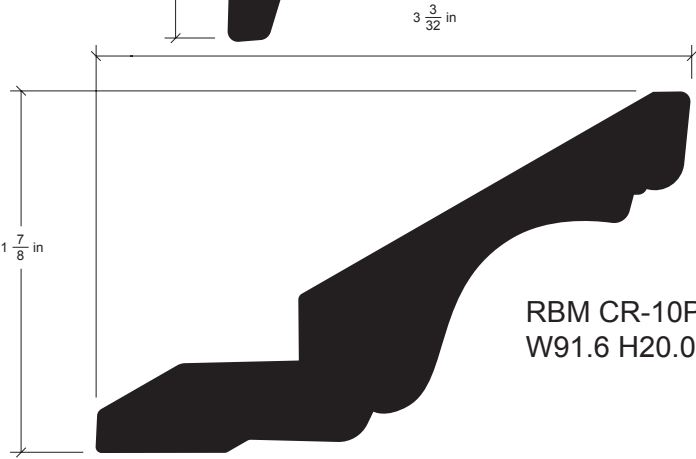

RBM CR-10P
W91.6 H20.00



RBM CR-13P
W168.4 H18.8

Available in any width.



RBM CR-11P
W43.5 H69.3



RBM CR-14P
W168.4 H18.8

Most Popular

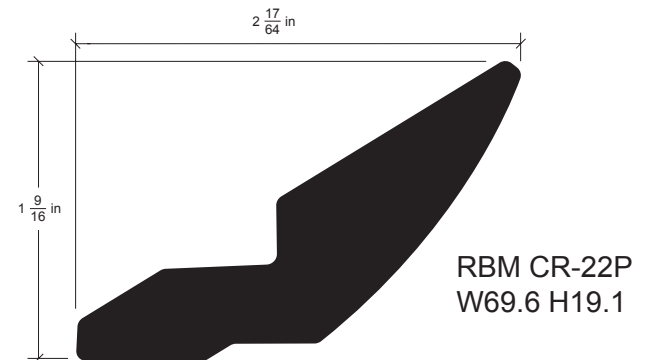
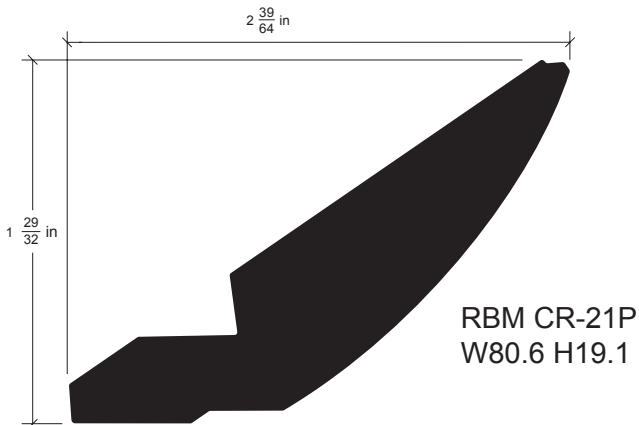
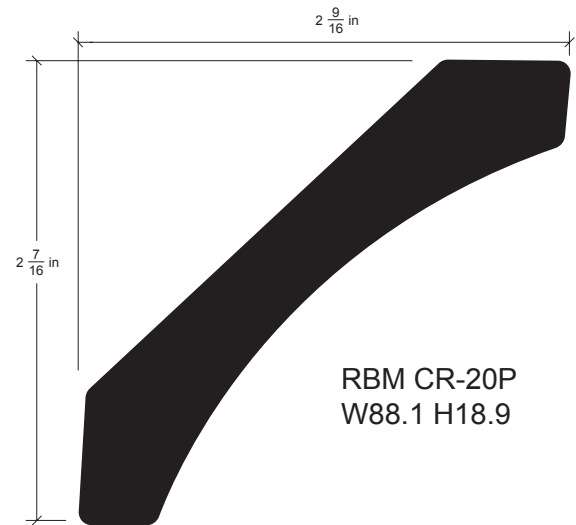
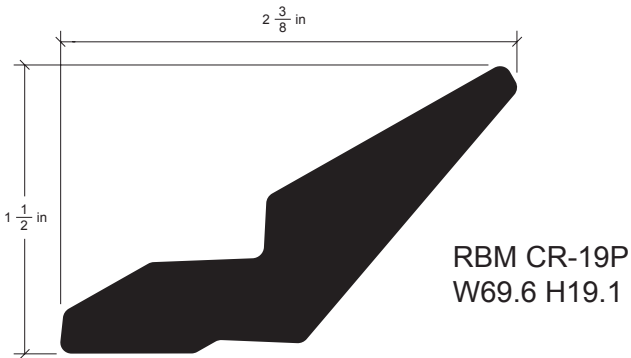
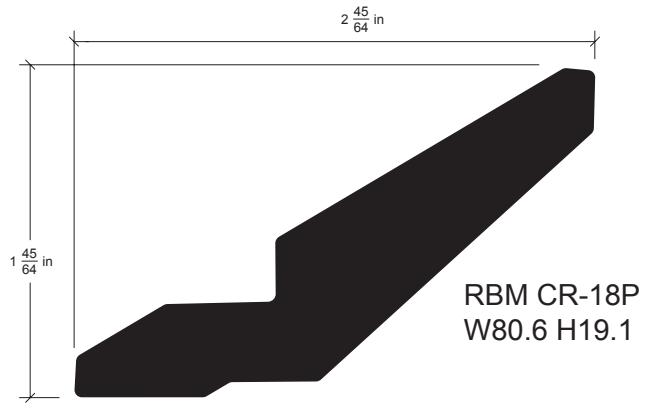
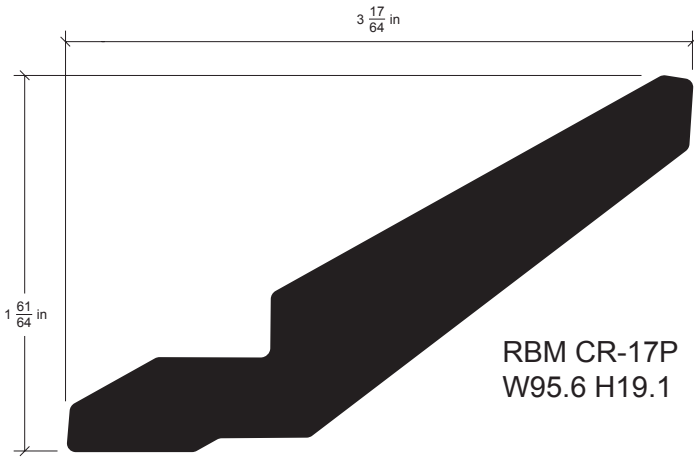
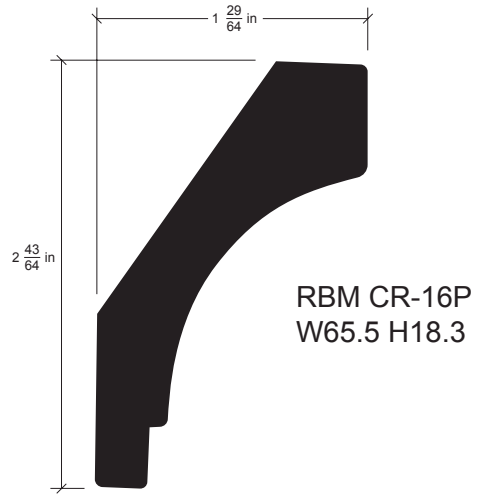
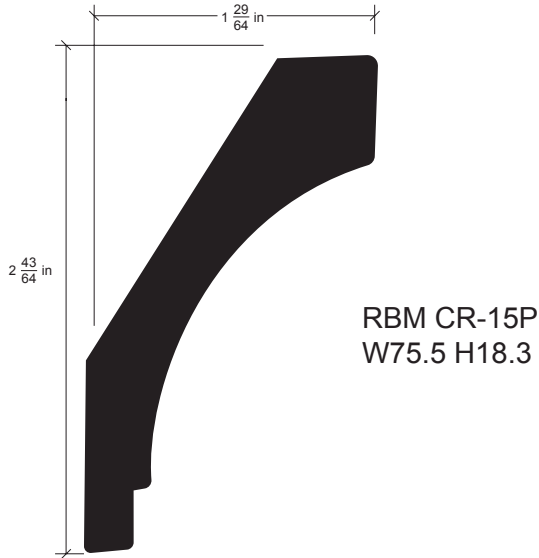

Most Popular

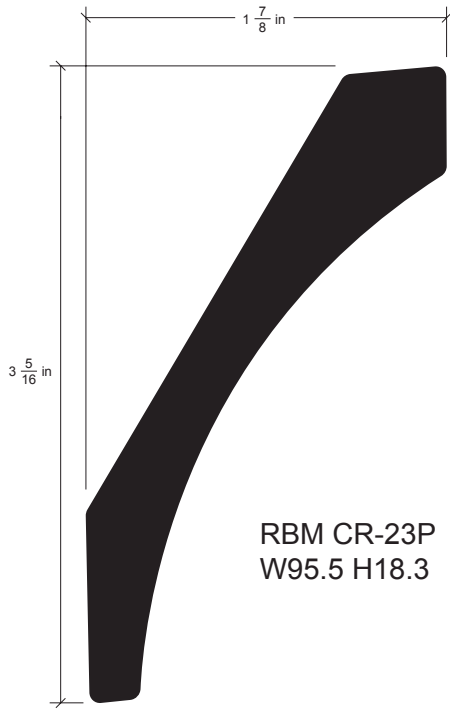

RBM CR-23P
W95.5 H18.3

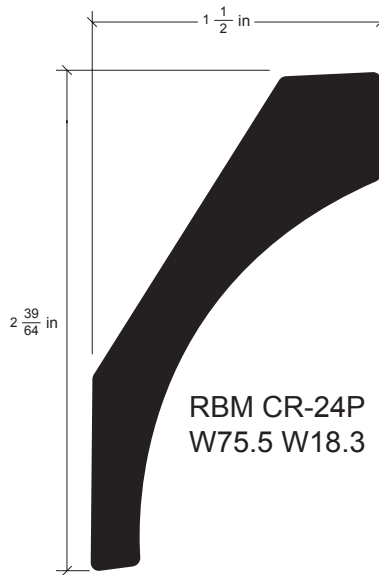

RBM CR-24P
W75.5 H18.3

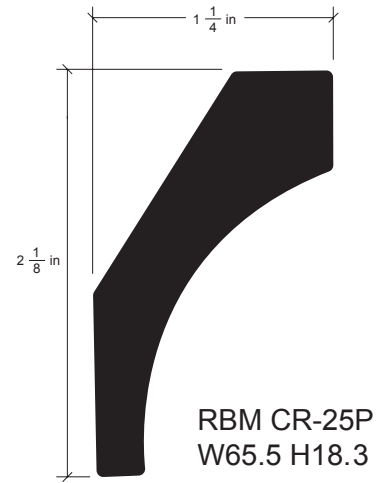

RBM CR-25P
W65.5 H18.3

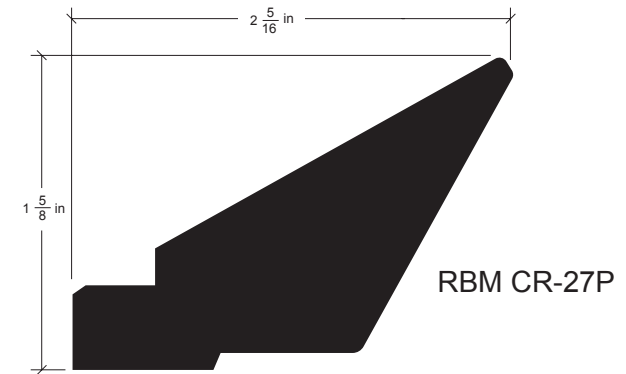

RBM CR-27P

Rails

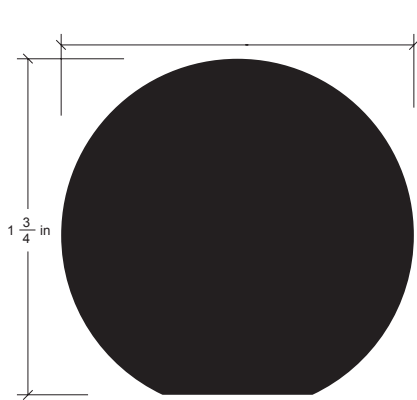

RBM HR-150

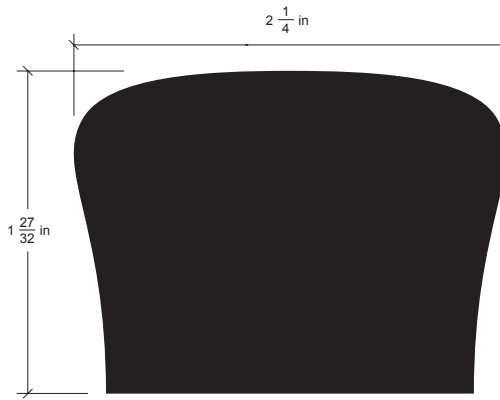

RBM HR-1P

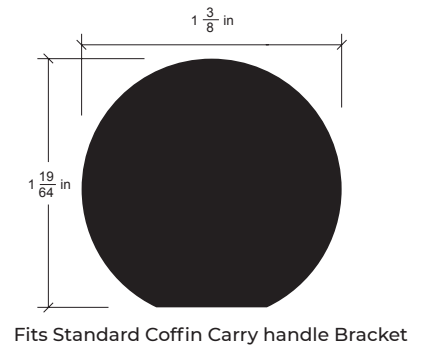

RBM HR-45

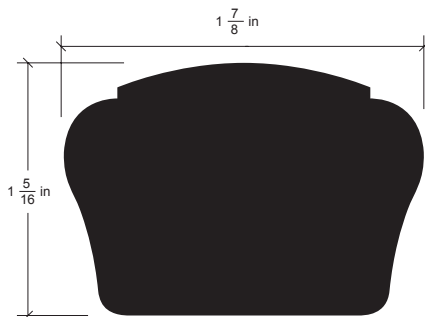

RBM HR-1

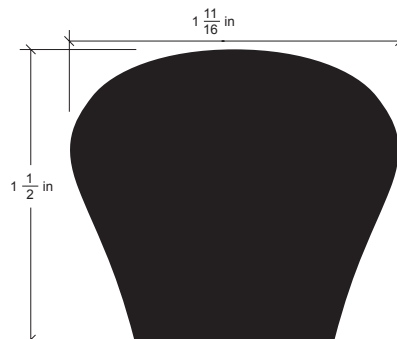

RBM HR-3

Crowns

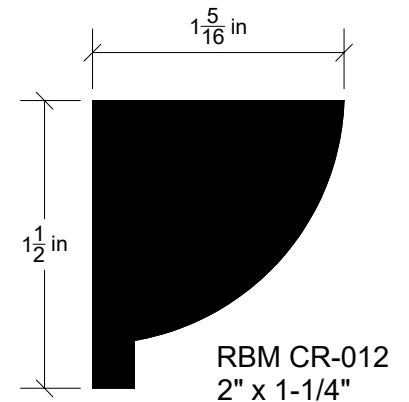
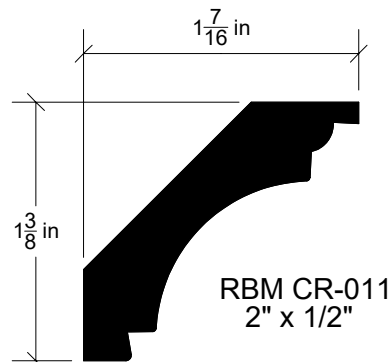
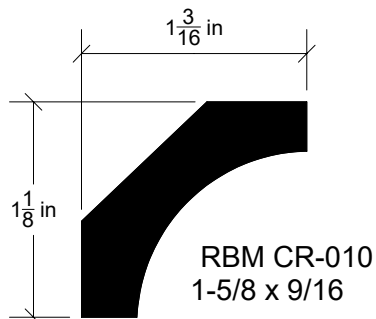
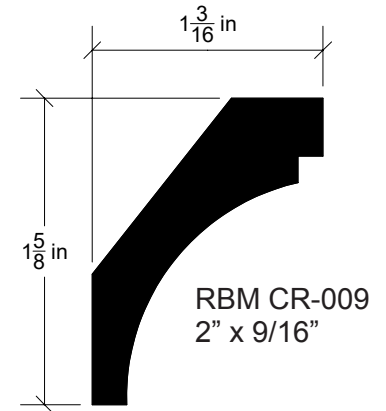
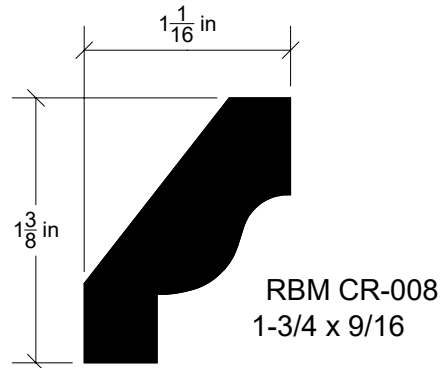
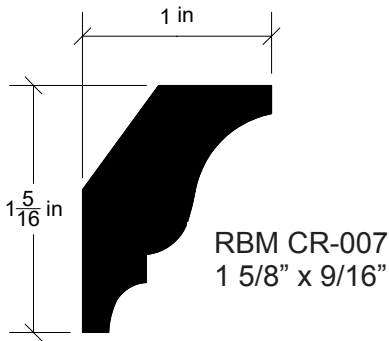
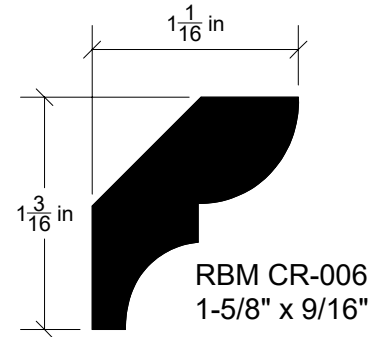
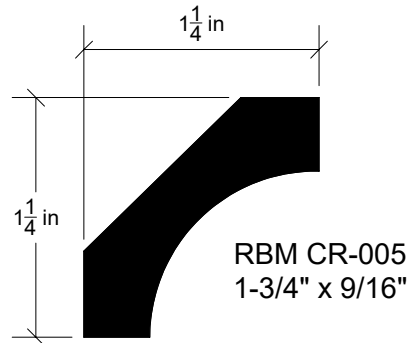
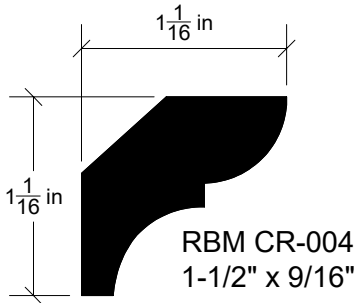
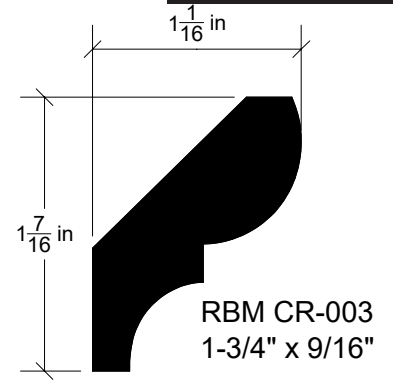
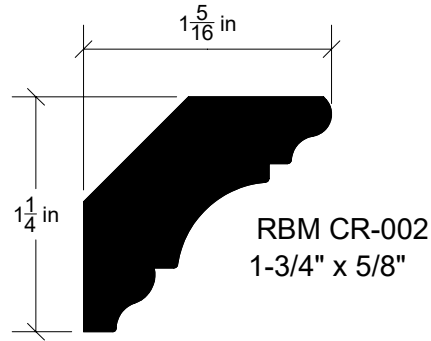
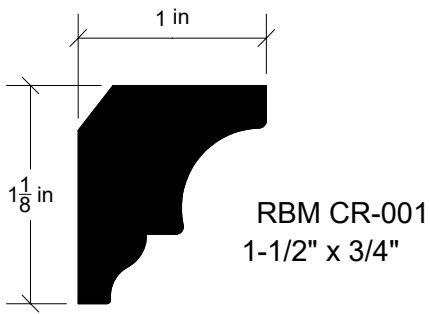

Crowns

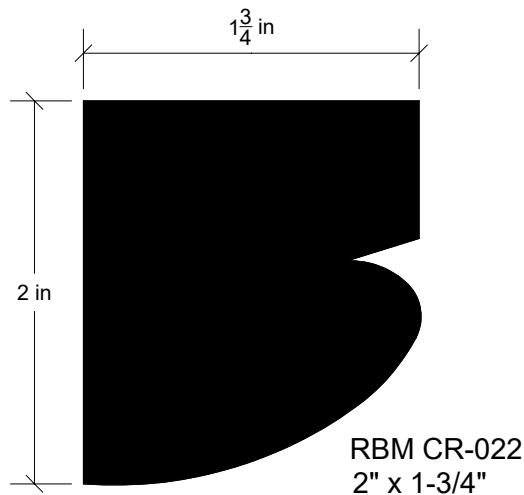
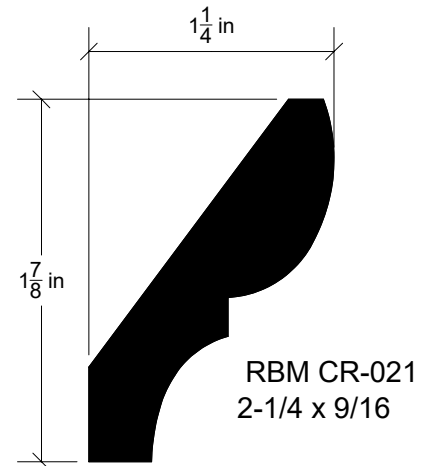
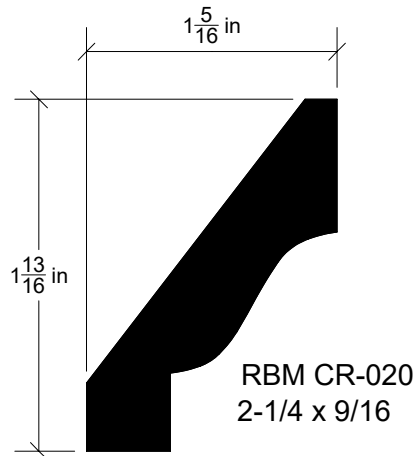
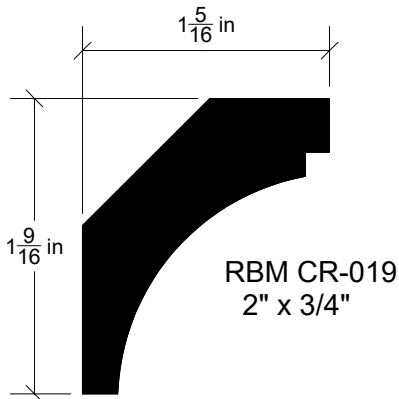
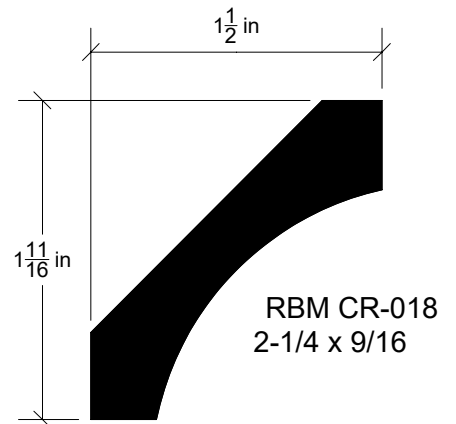
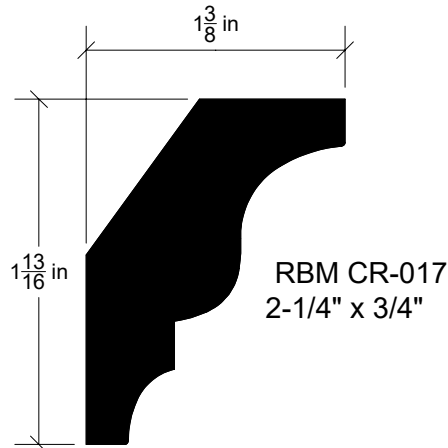
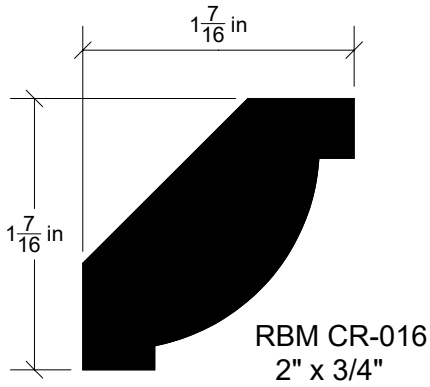
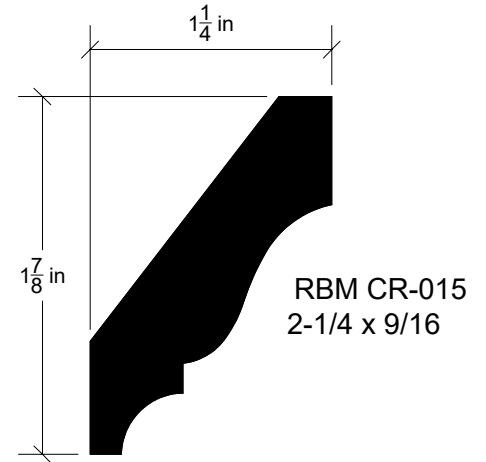
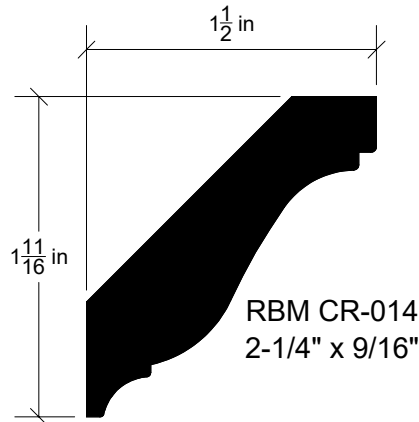
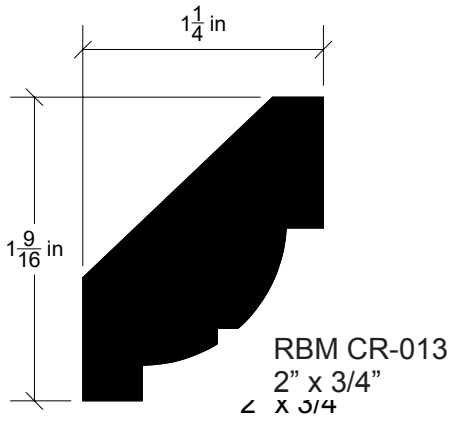

We love woodworking, and it shows... it is our pleasure to create lasting products for you.

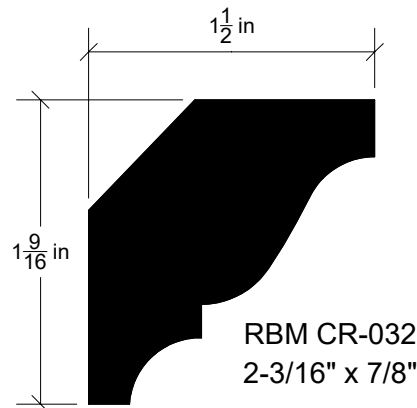
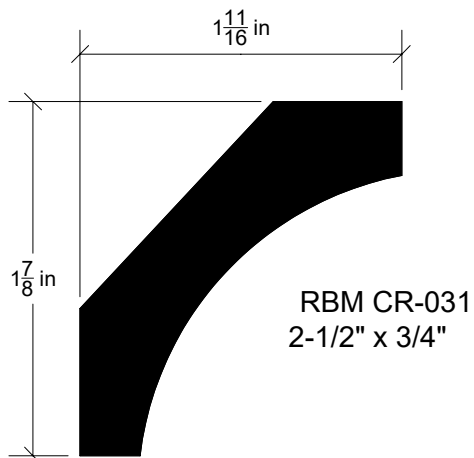
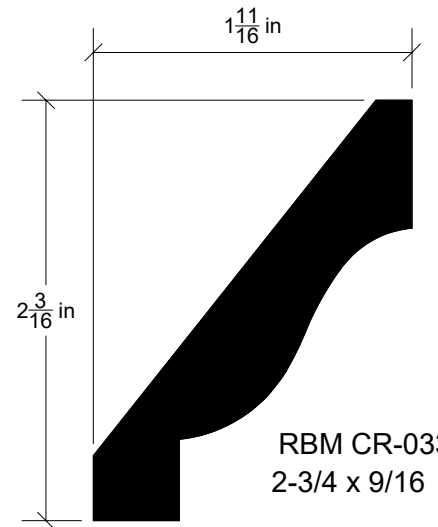
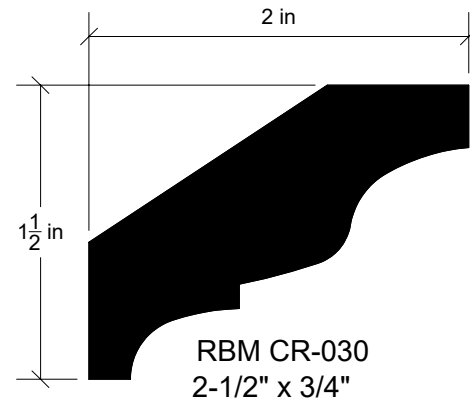
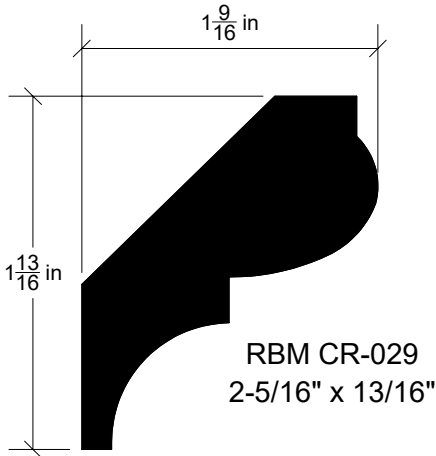
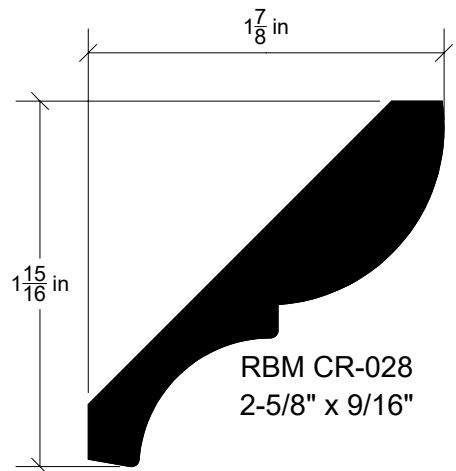
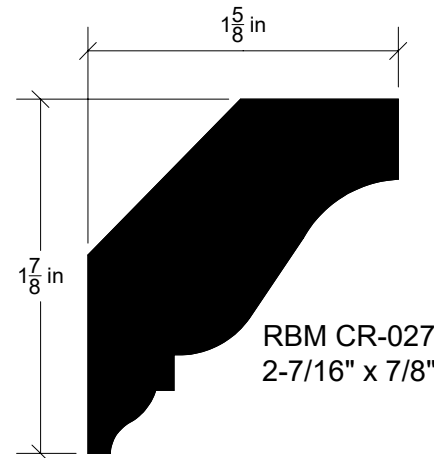
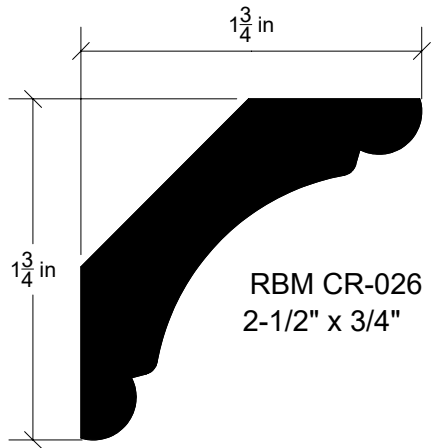
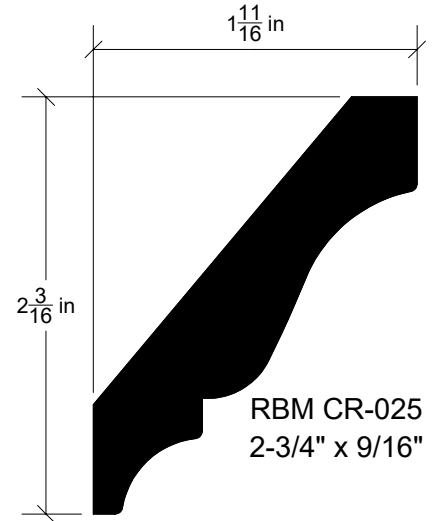
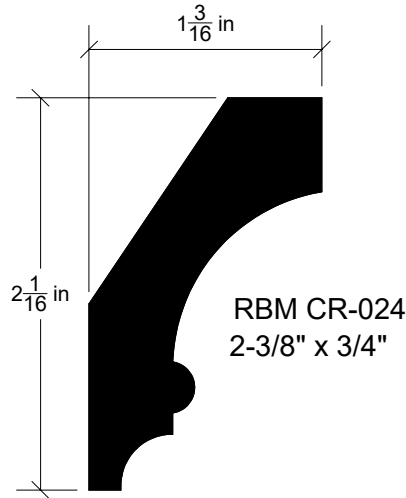
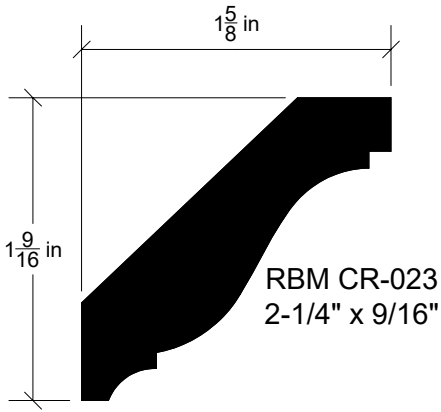

Crowns

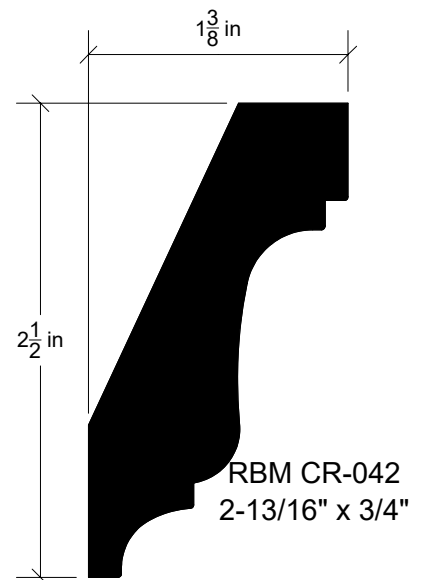
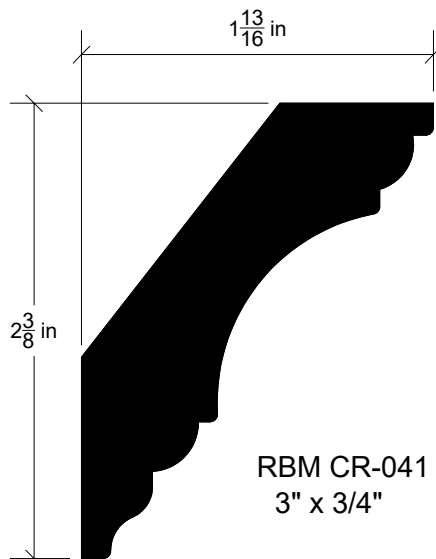
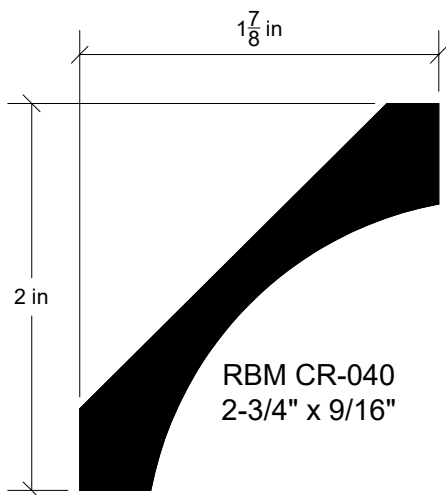
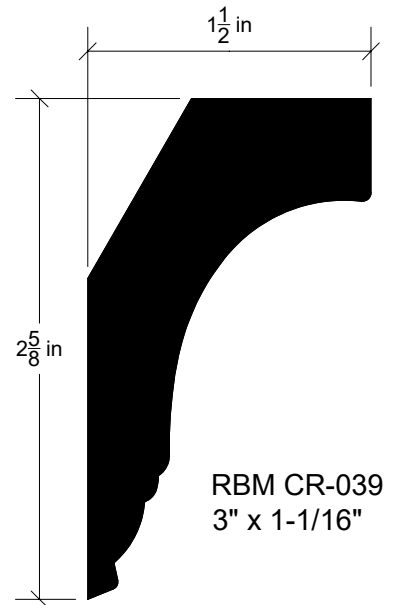
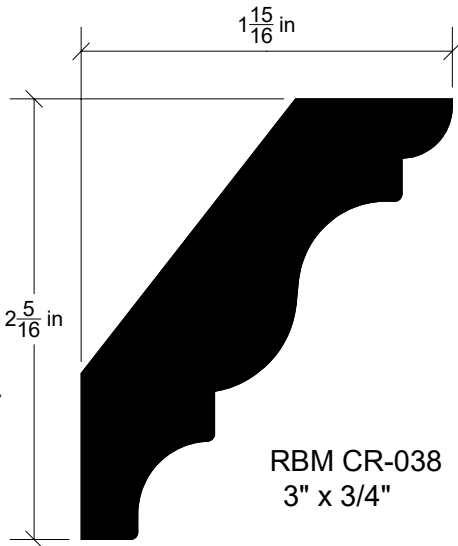
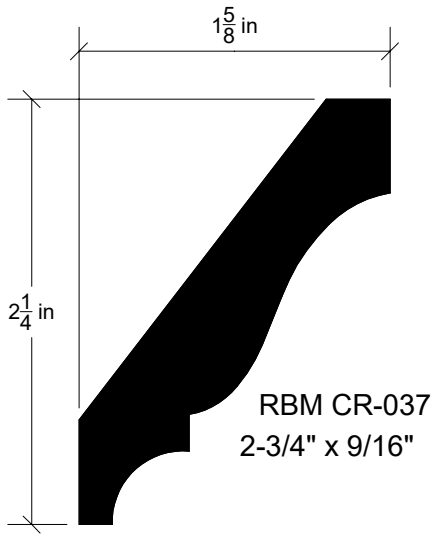
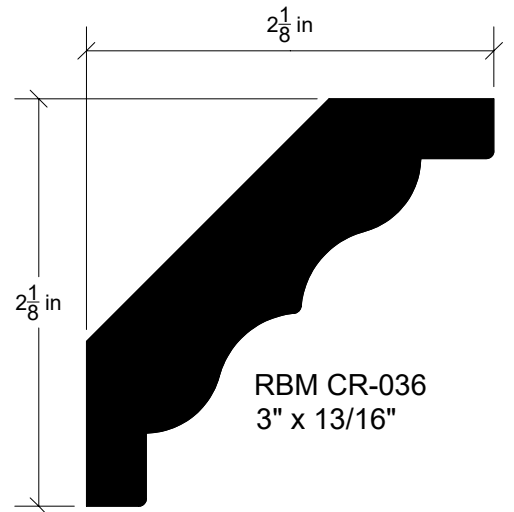
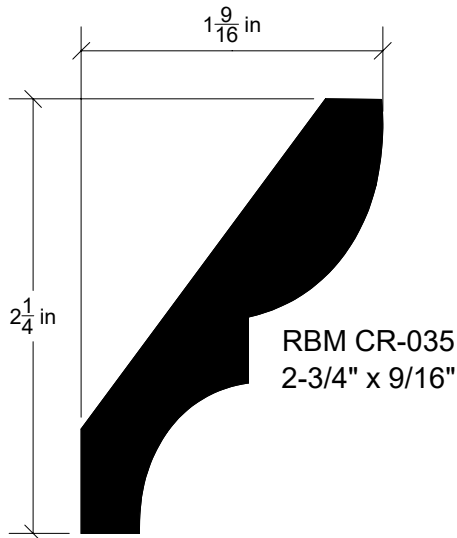
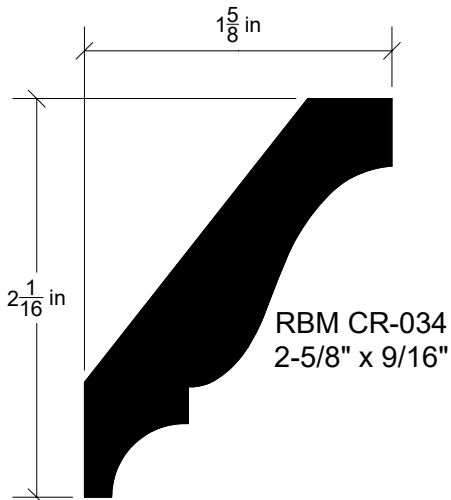

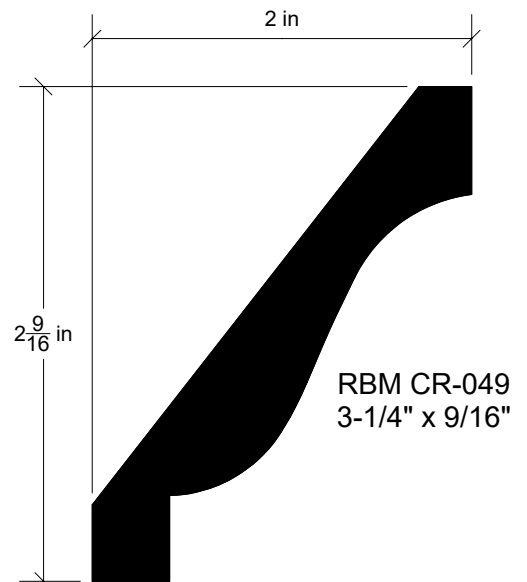
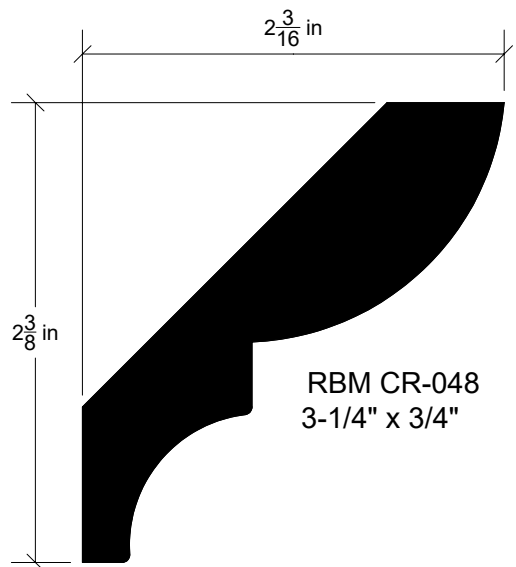
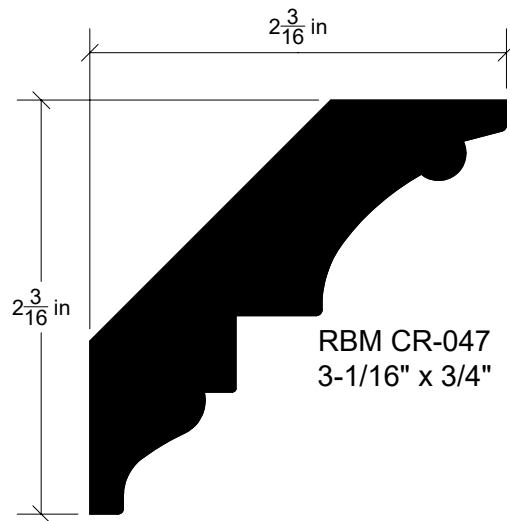
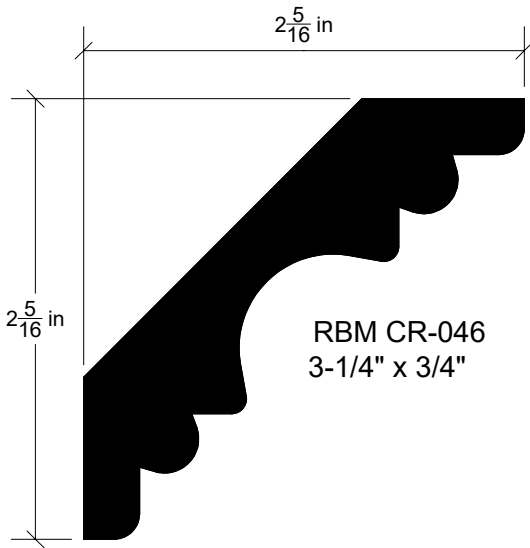
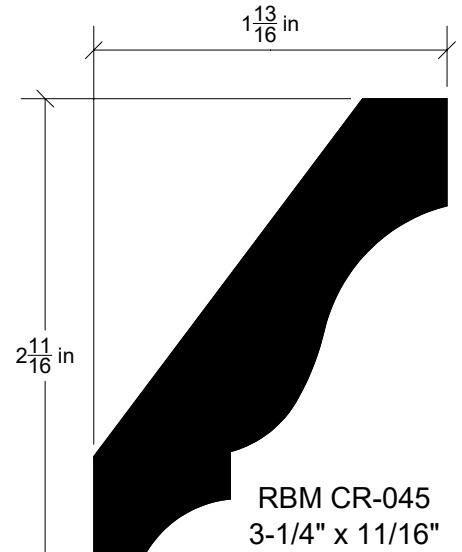
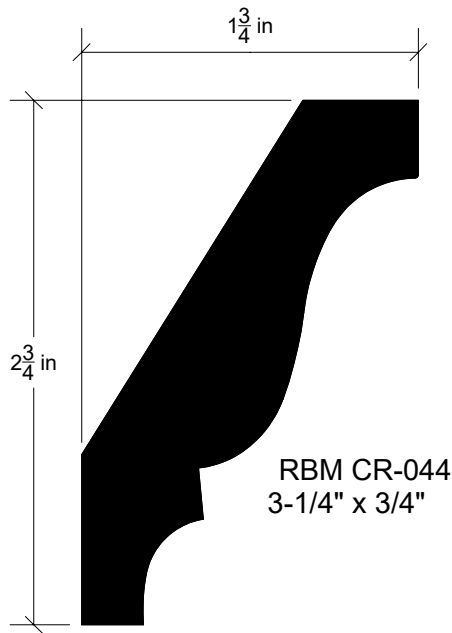
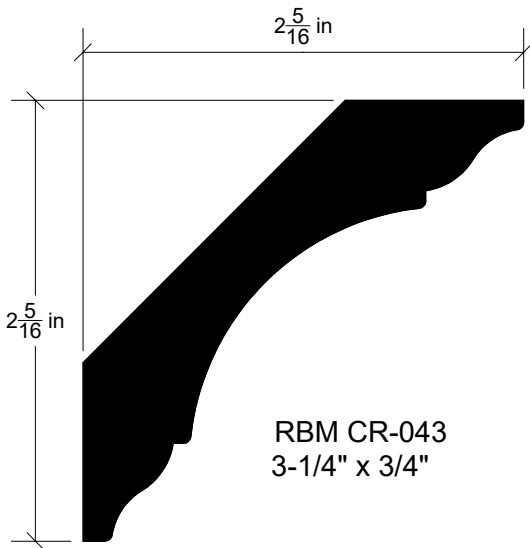

Crowns

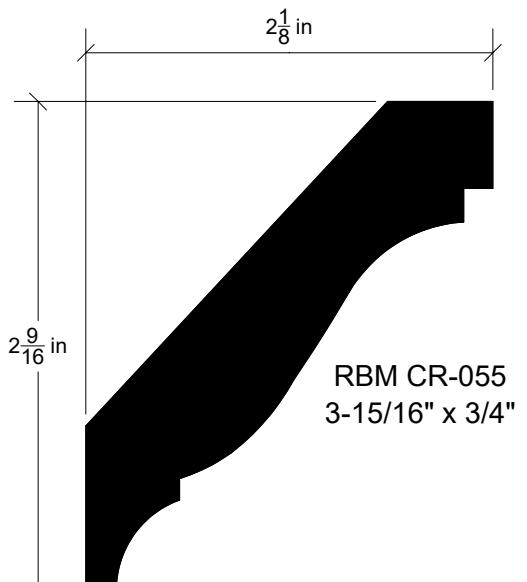
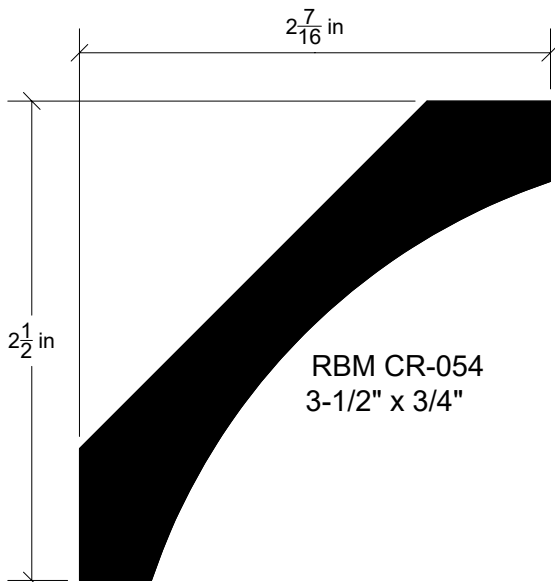
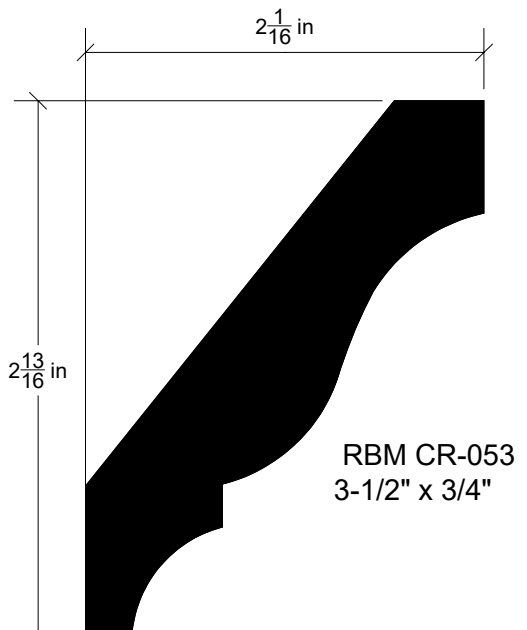
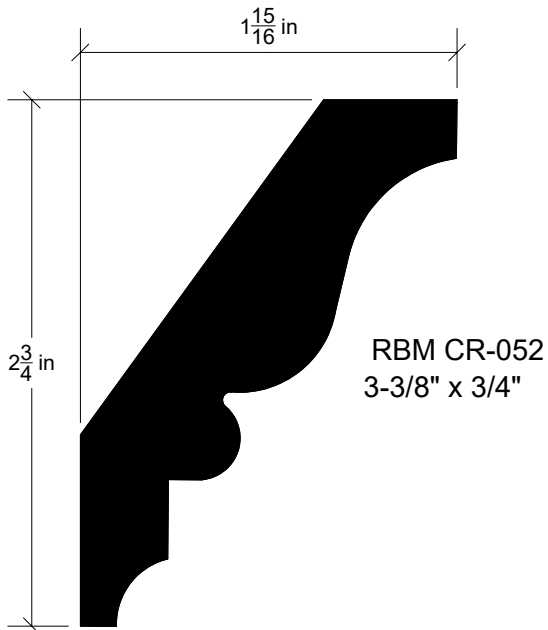
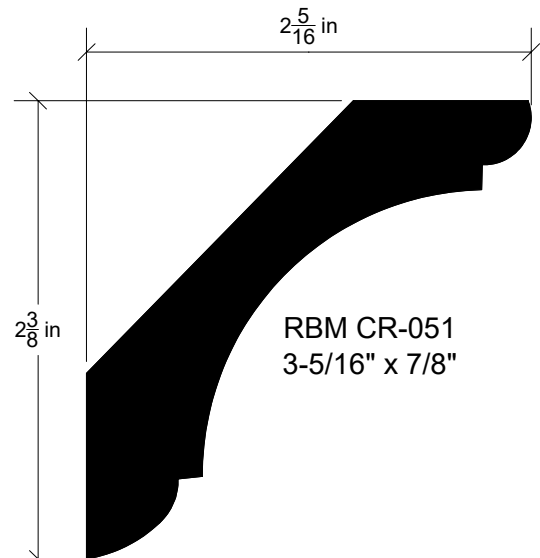
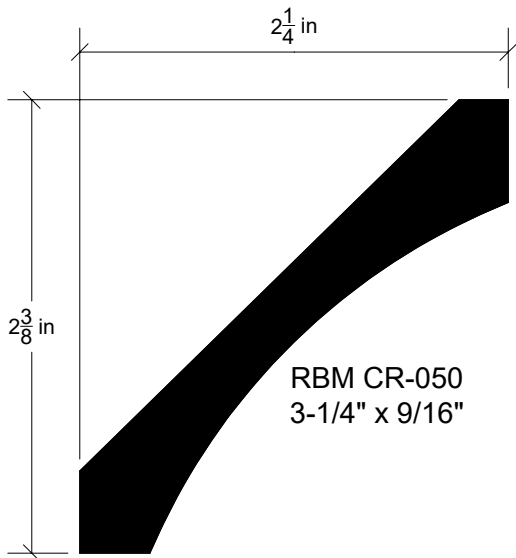

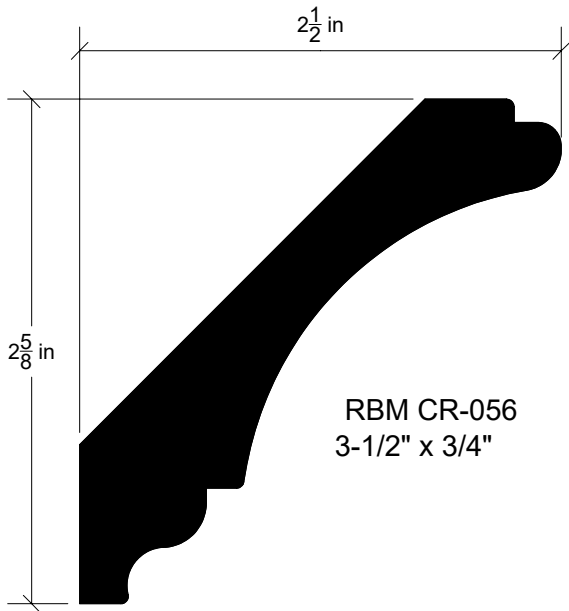

RBM CR-056
3-1/2" x 3/4"

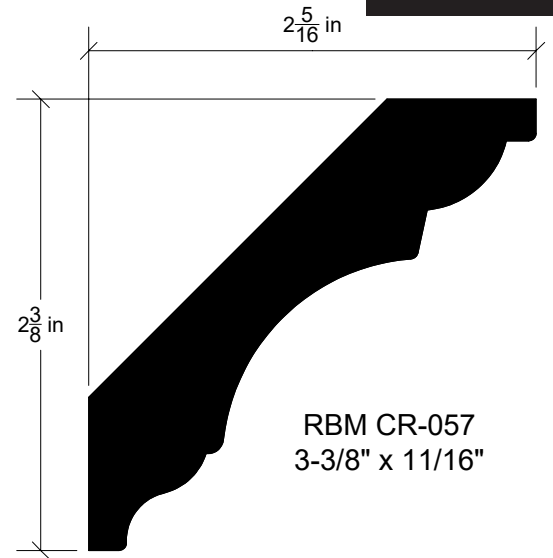

RBM CR-057
3-3/8" x 11/16"

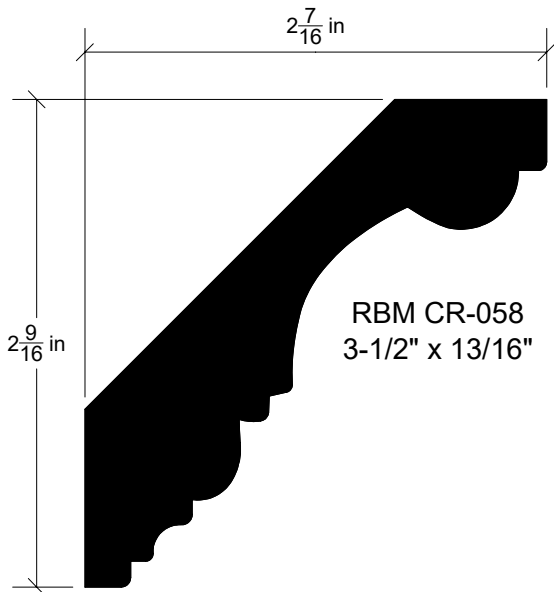

RBM CR-058
3-1/2" x 13/16"

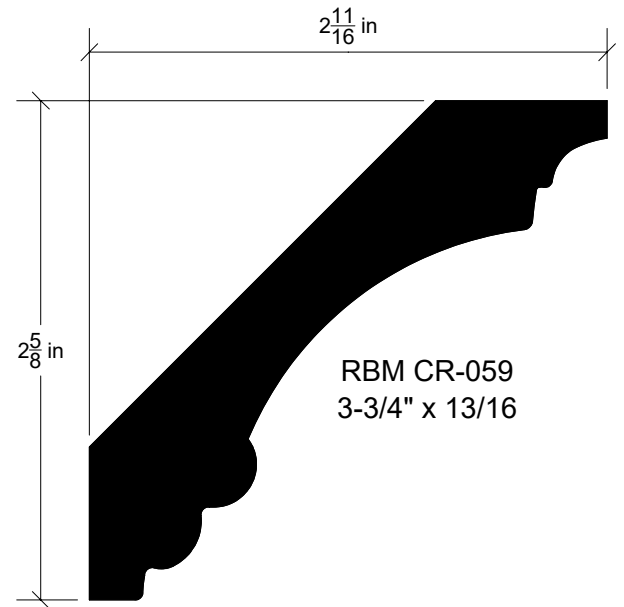

RBM CR-059
3-3/4" x 13/16"

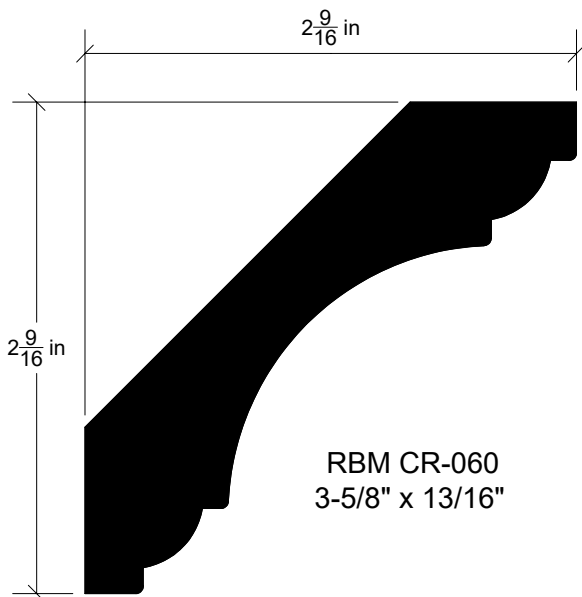

RBM CR-060
3-5/8" x 13/16"

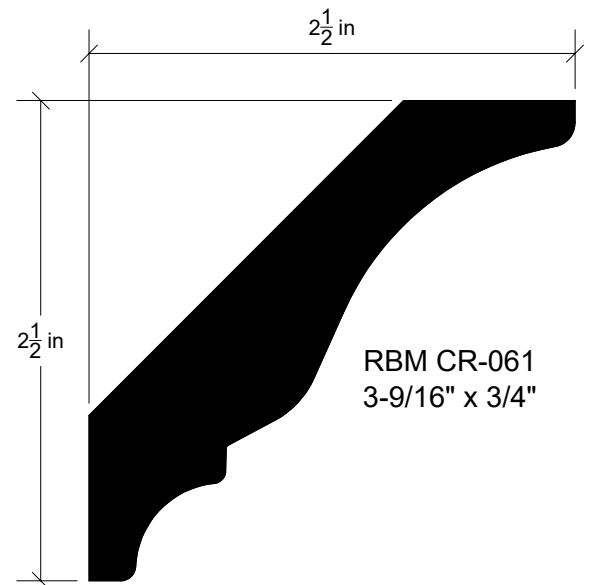

RBM CR-061
3-9/16" x 3/4"

Crowns

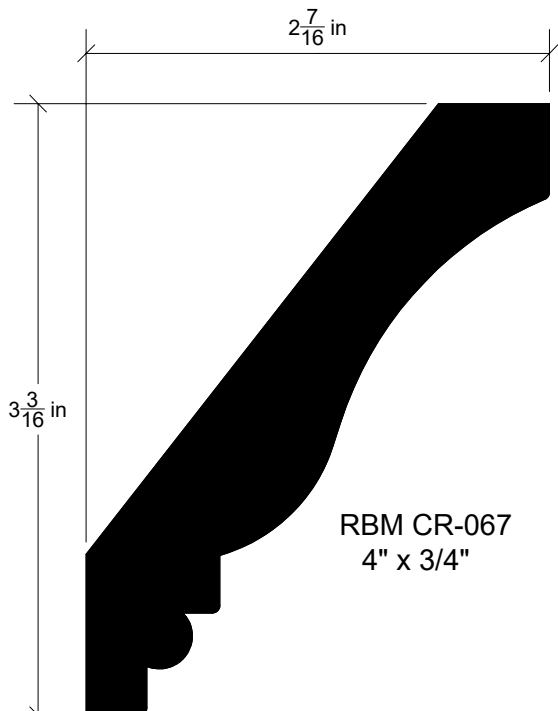
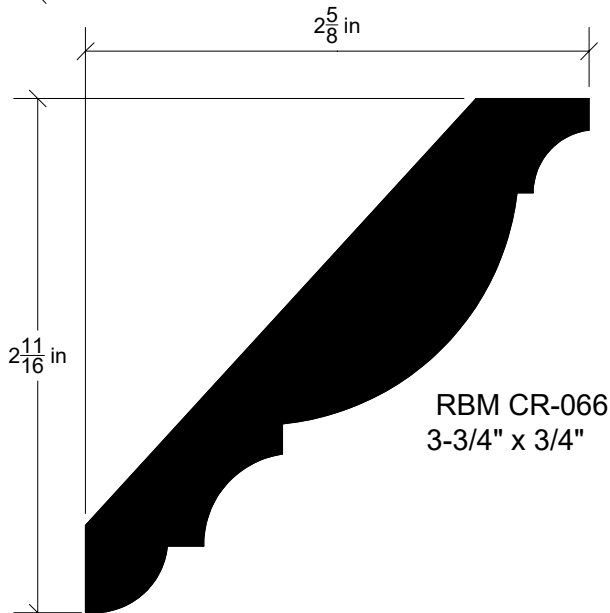
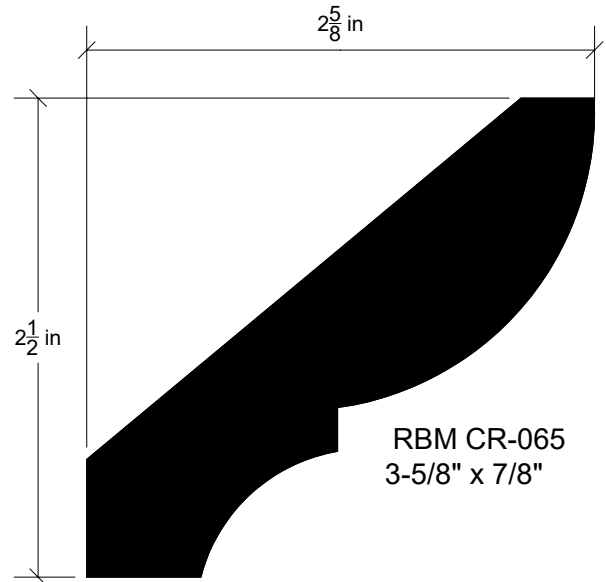
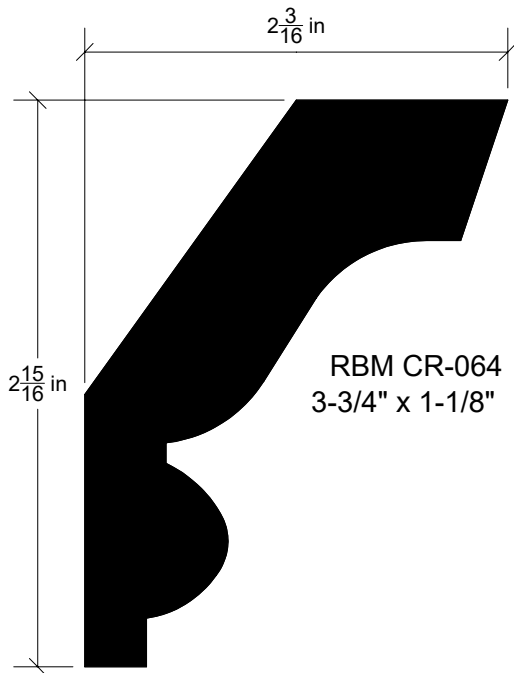
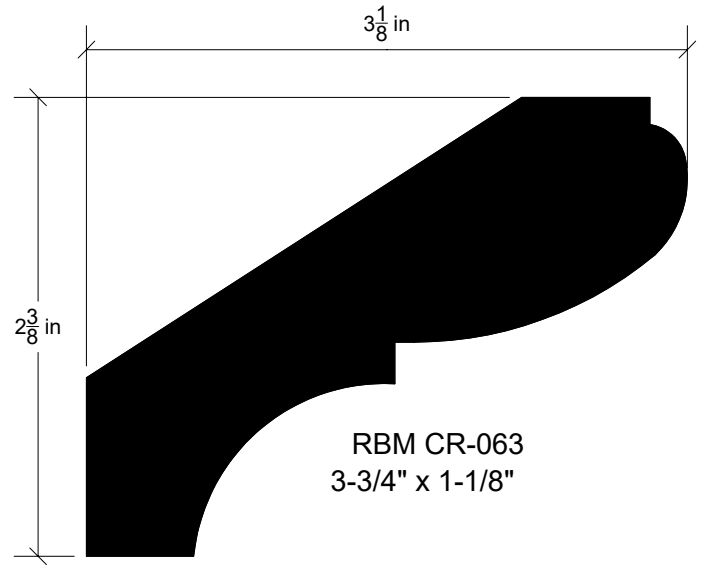
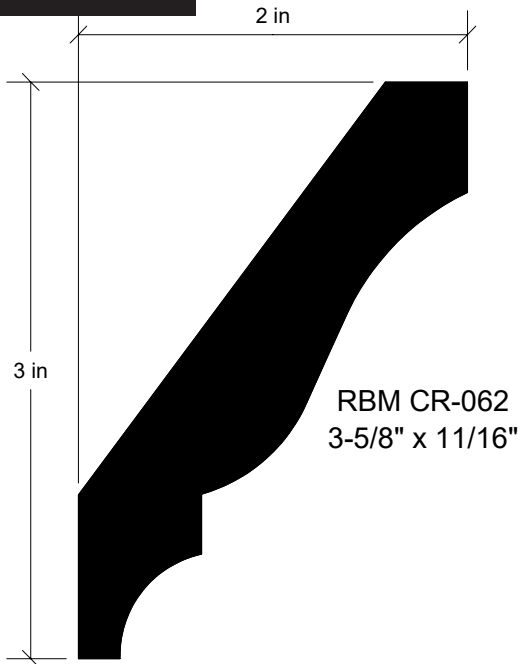

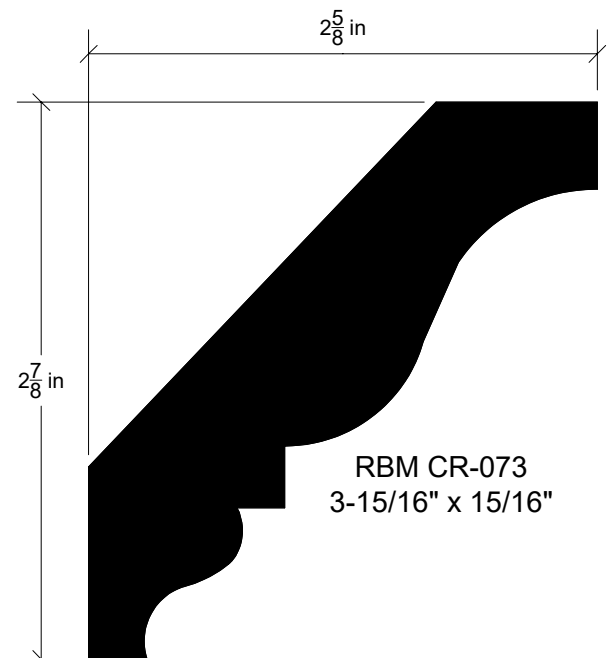
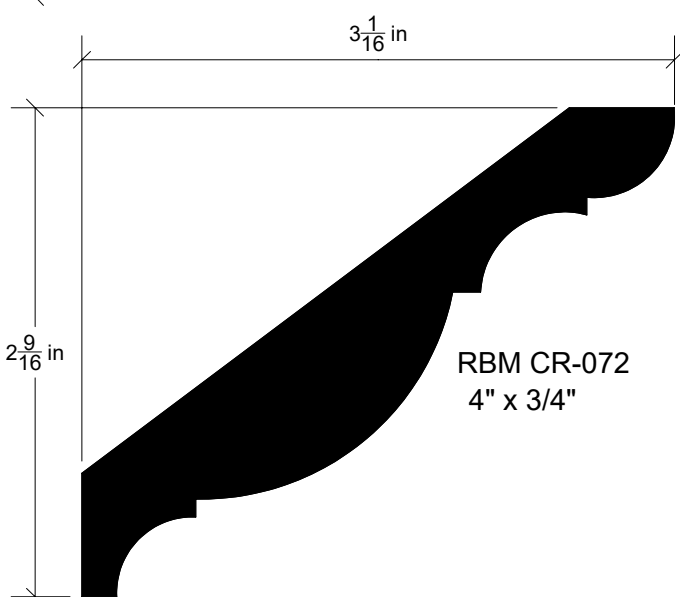
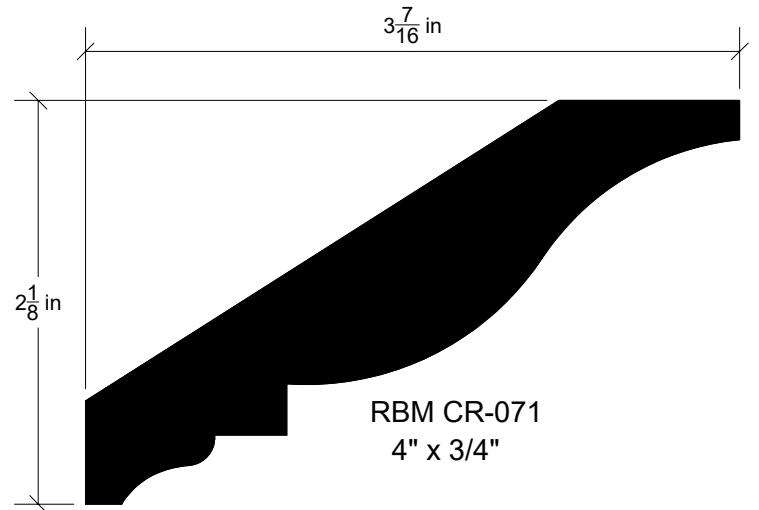
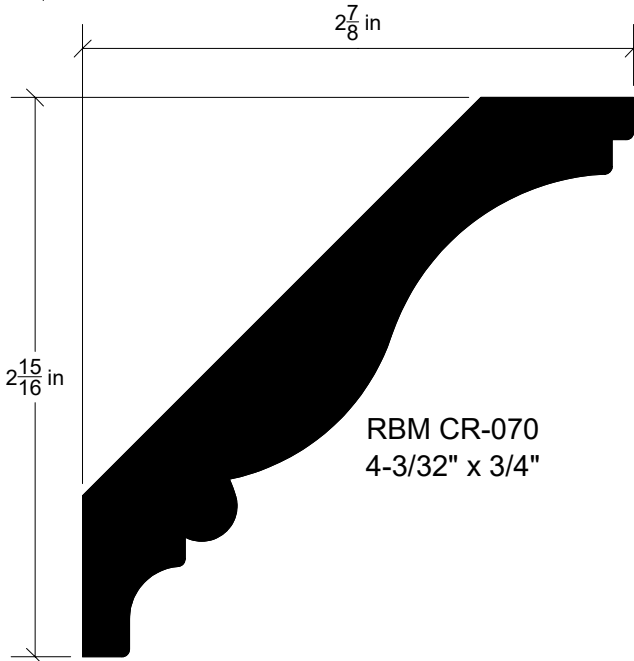
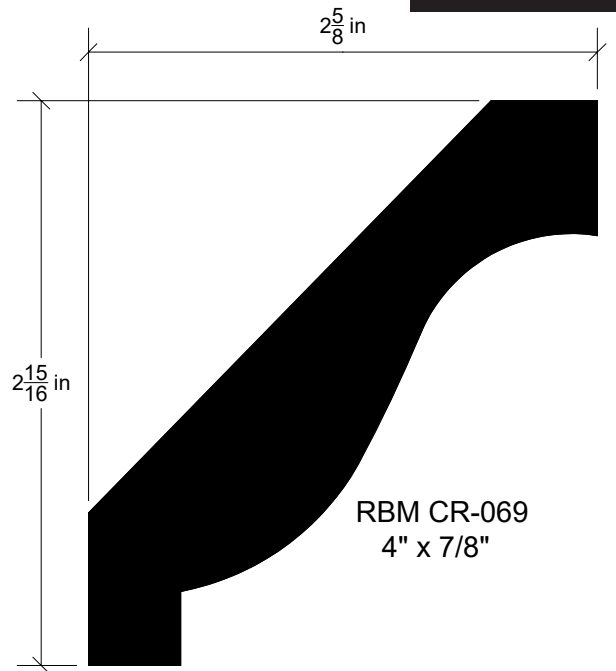
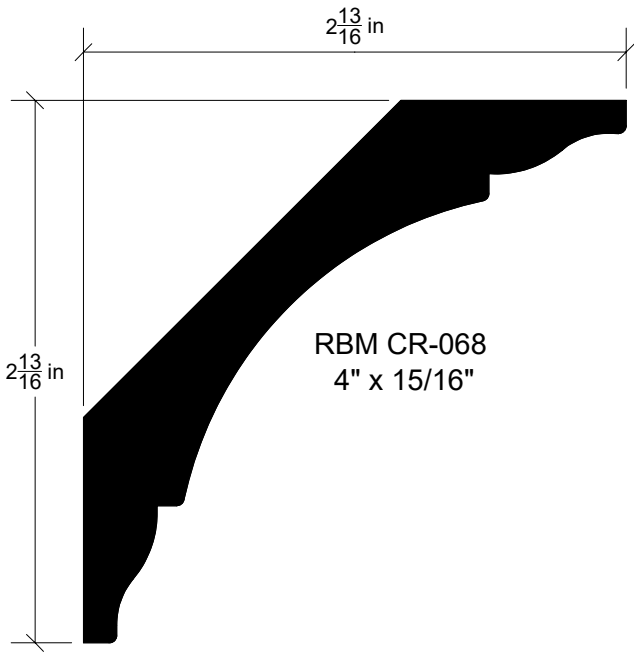

Crowns

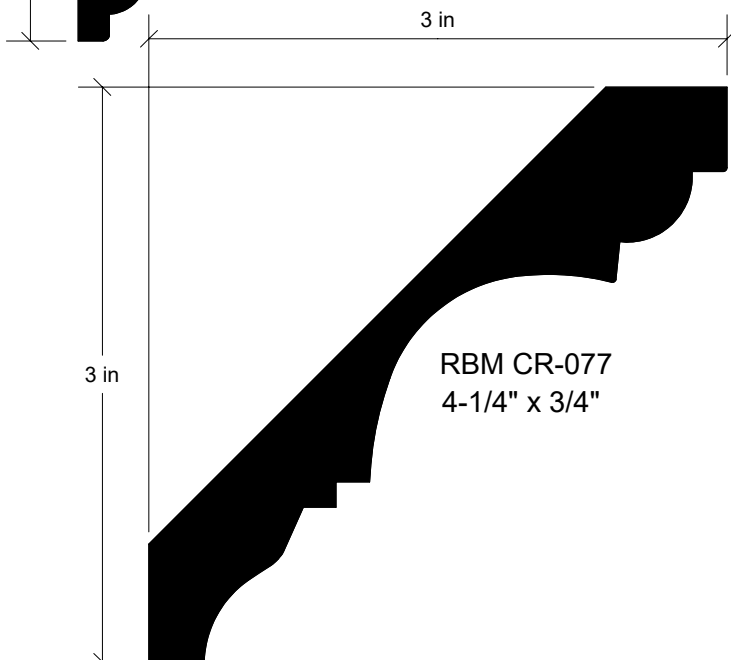
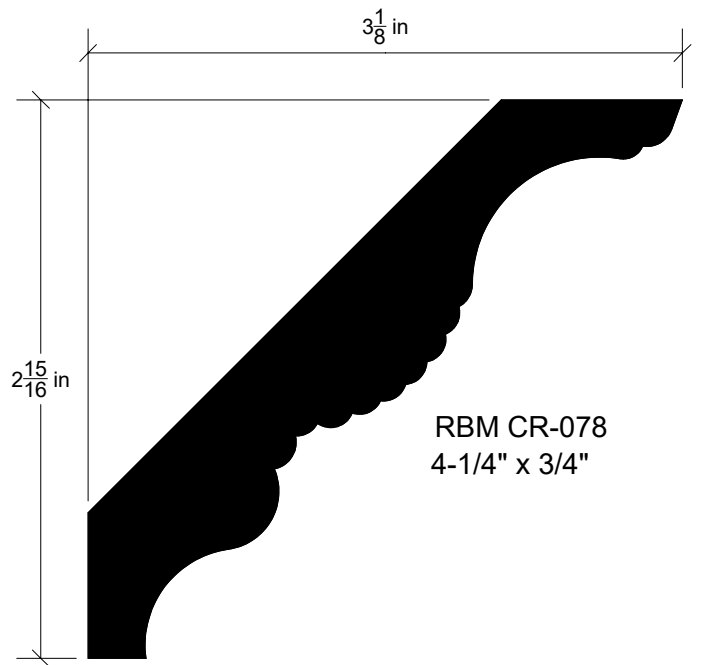
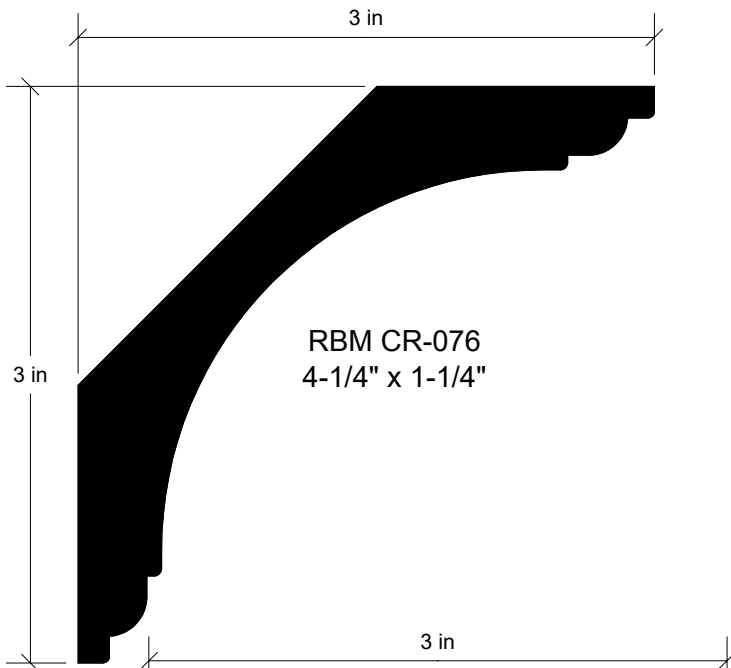
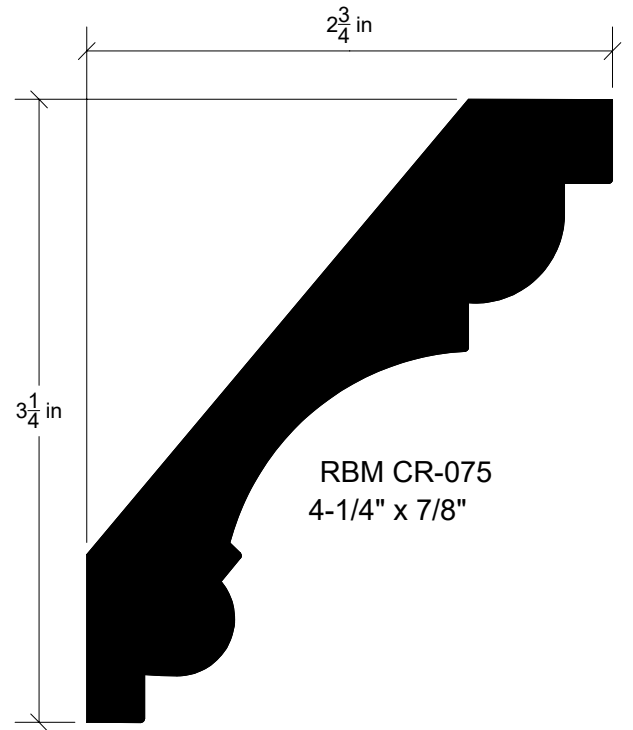
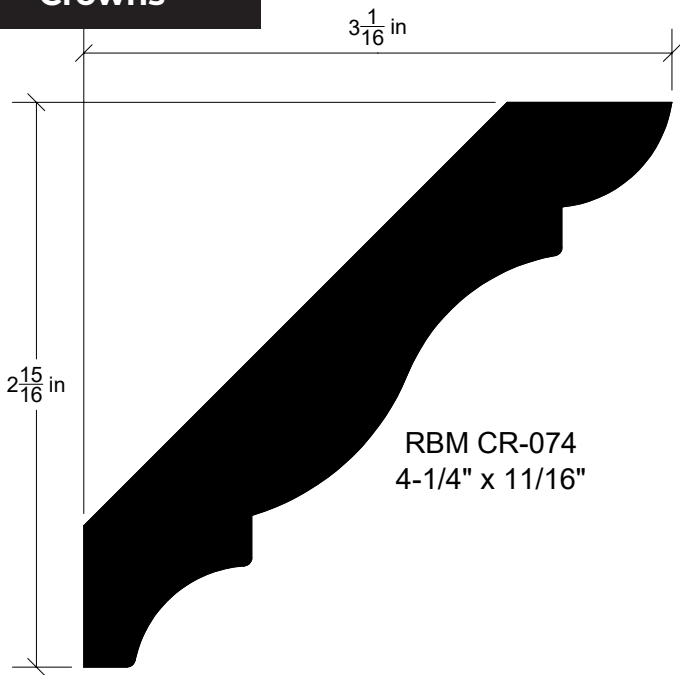

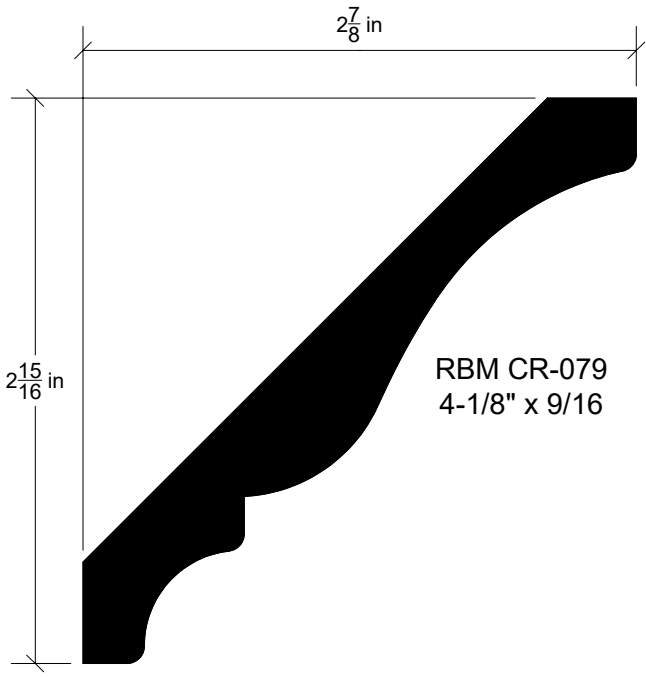

RBM CR-079
4-1/8" x 9/16"

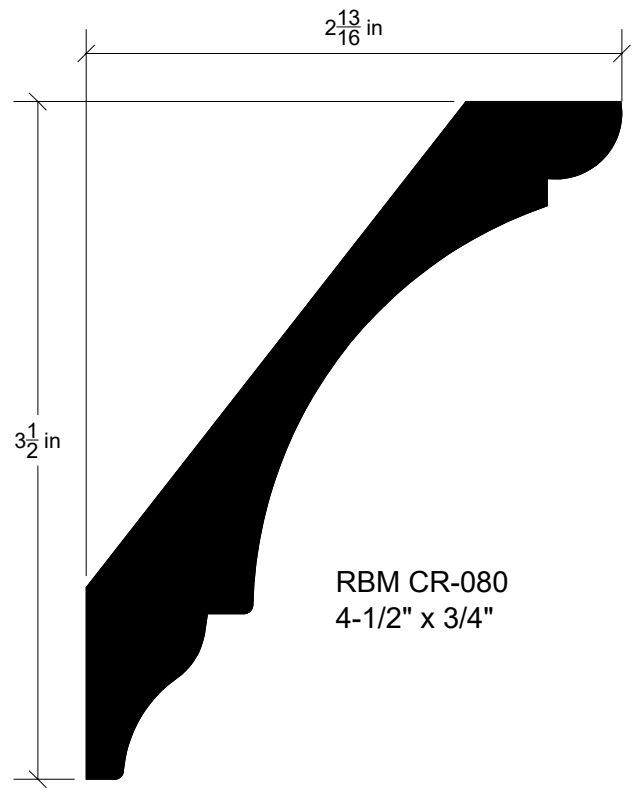

RBM CR-080
4-1/2" x 3/4"

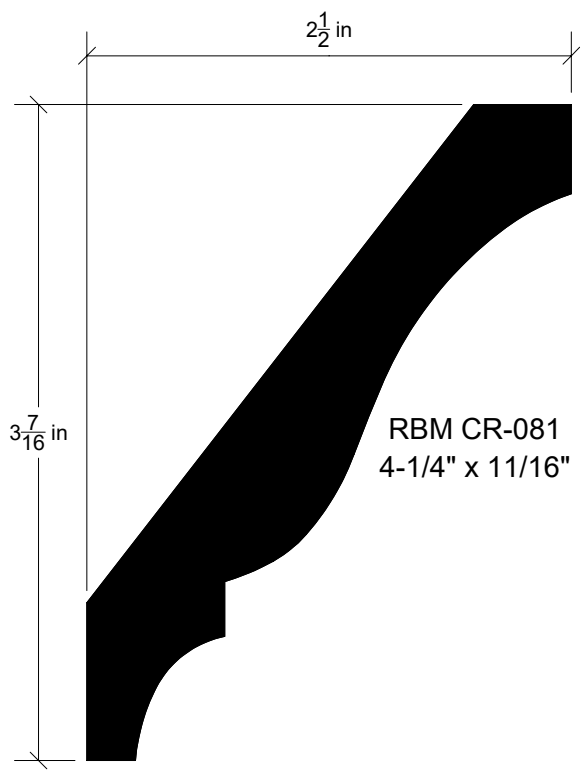

RBM CR-081
4-1/4" x 11/16"

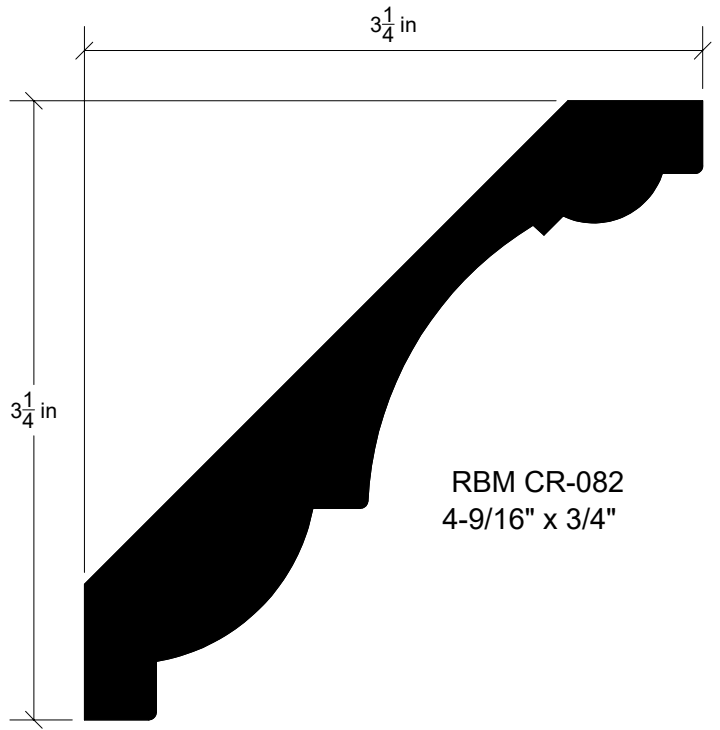

RBM CR-082
4-9/16" x 3/4"

Crowns

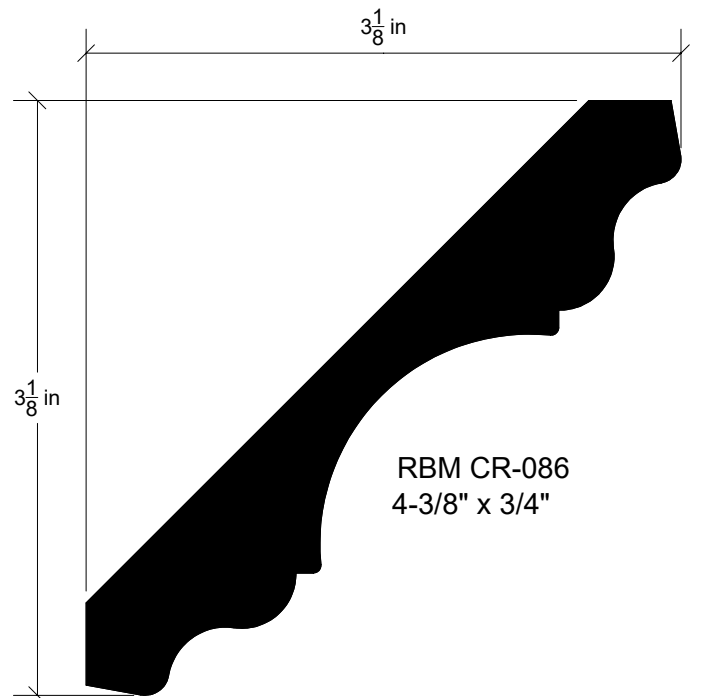
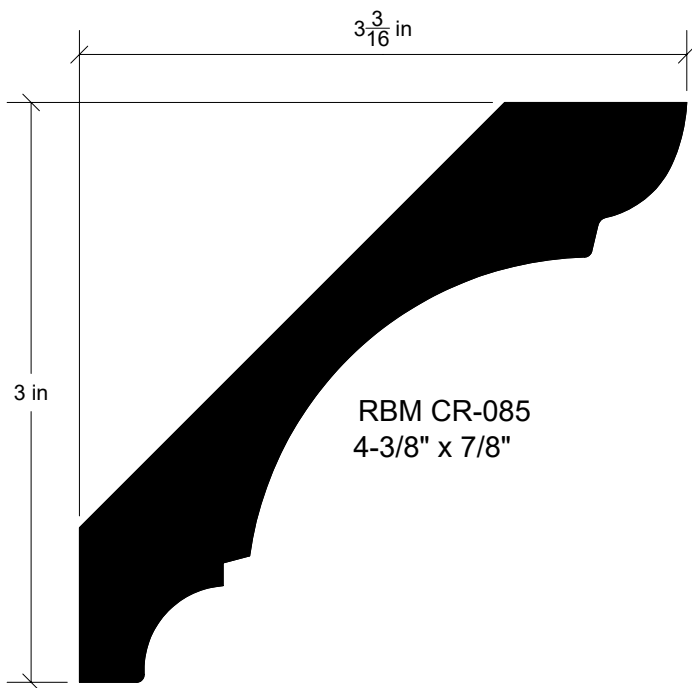
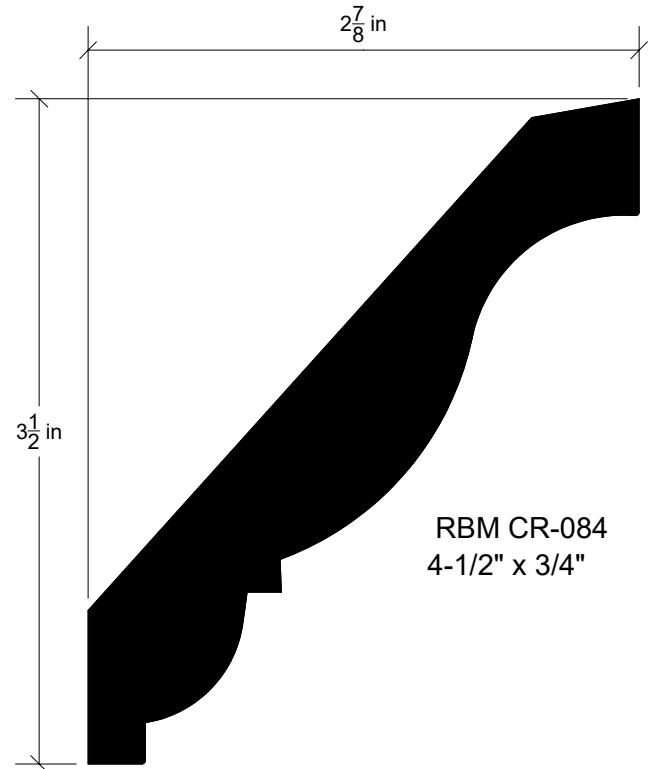
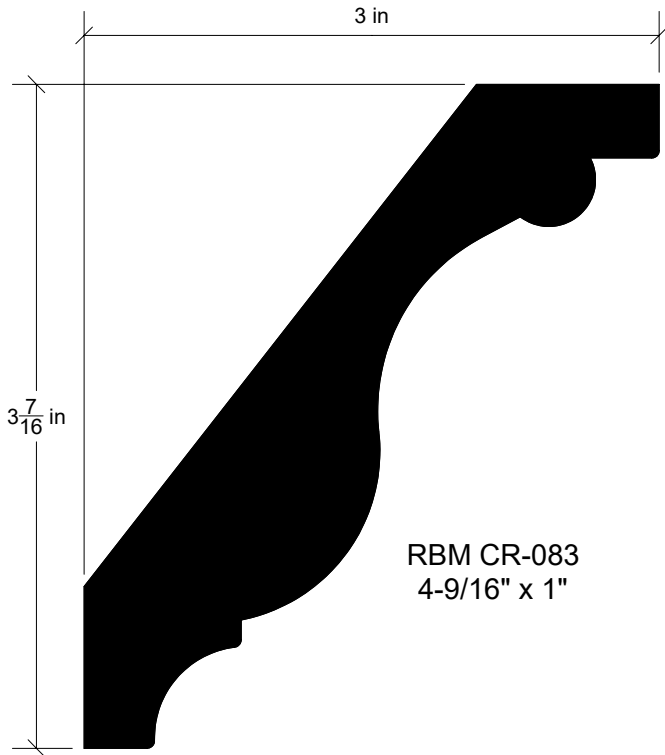

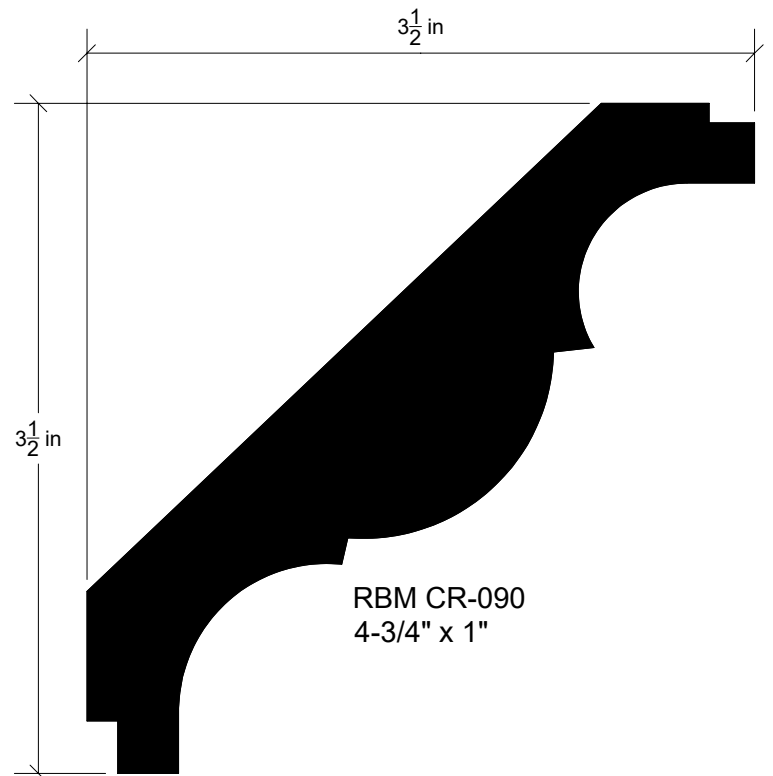
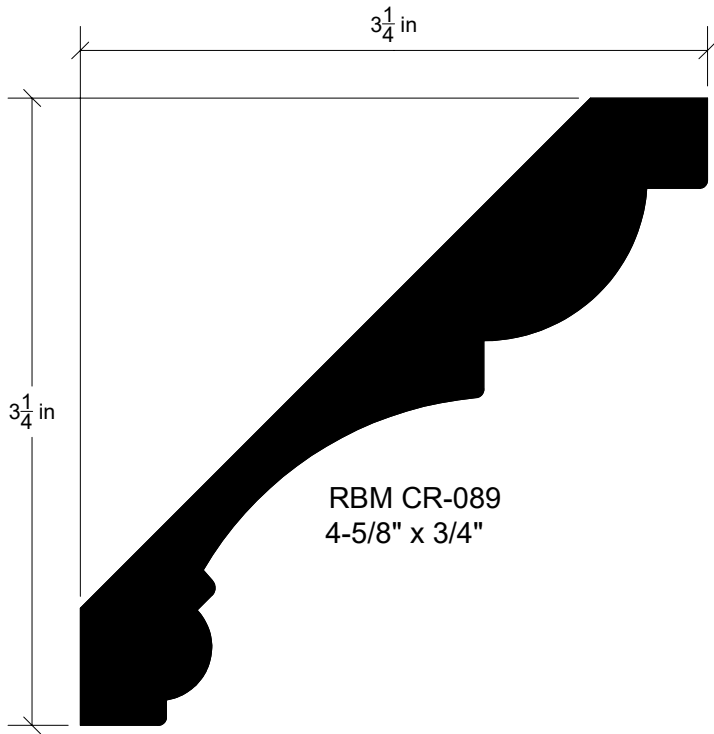
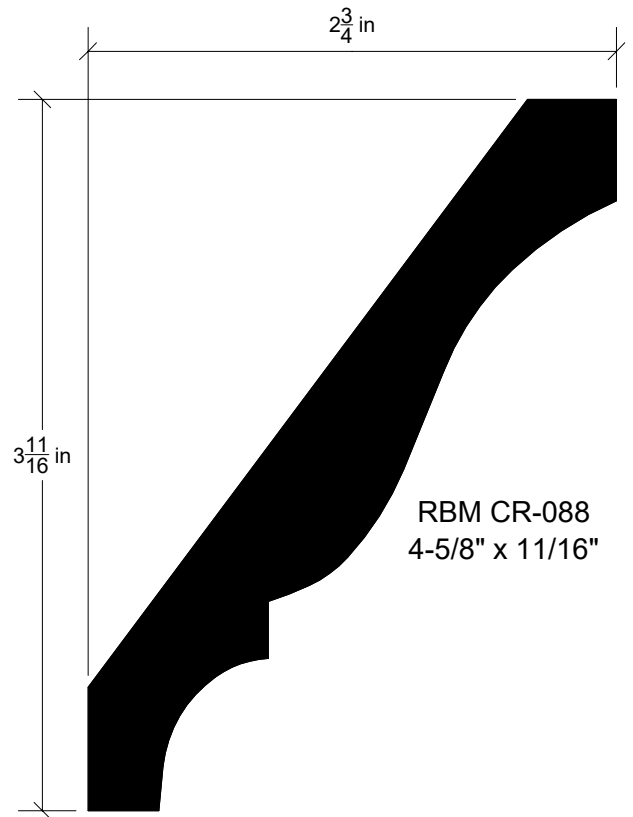
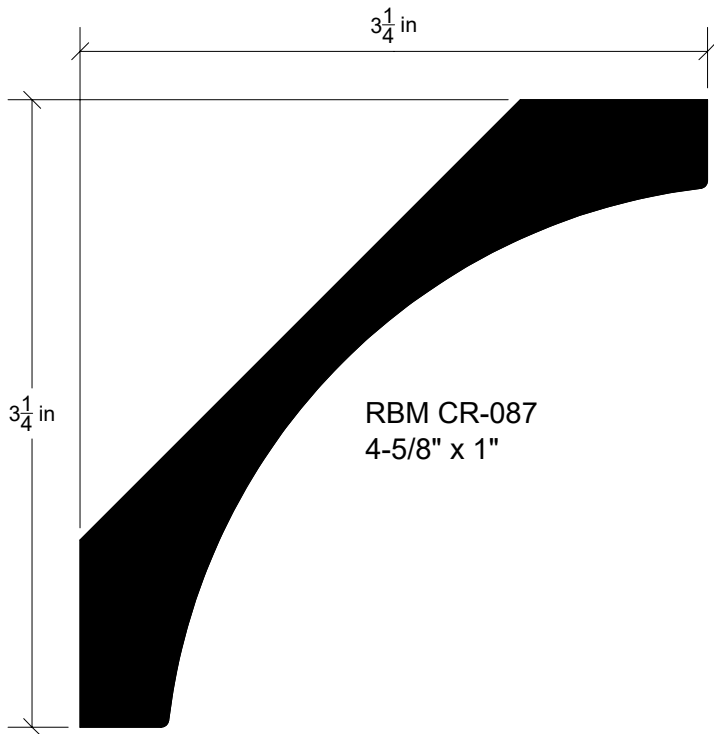

Crowns

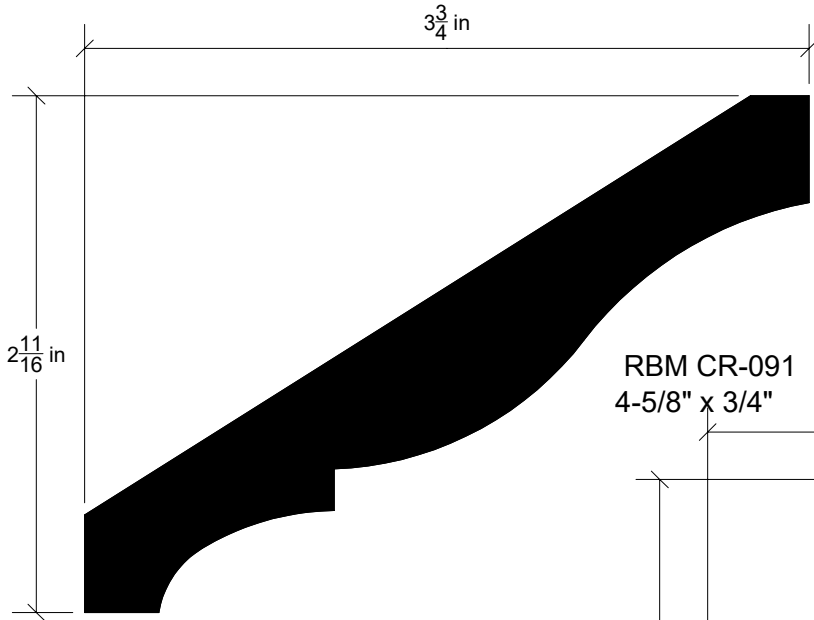

RBM CR-091
4-5/8" x 3/4"

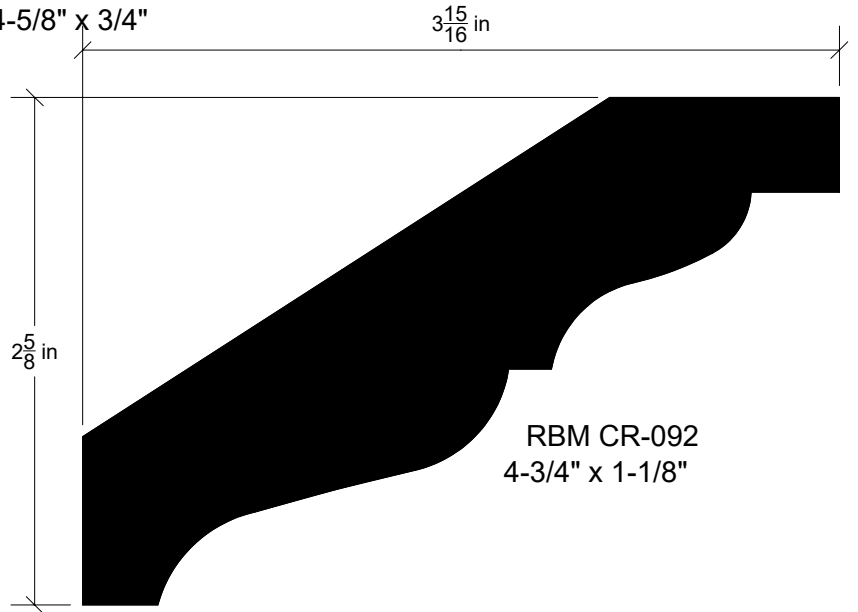

RBM CR-092
4-3/4" x 1-1/8"

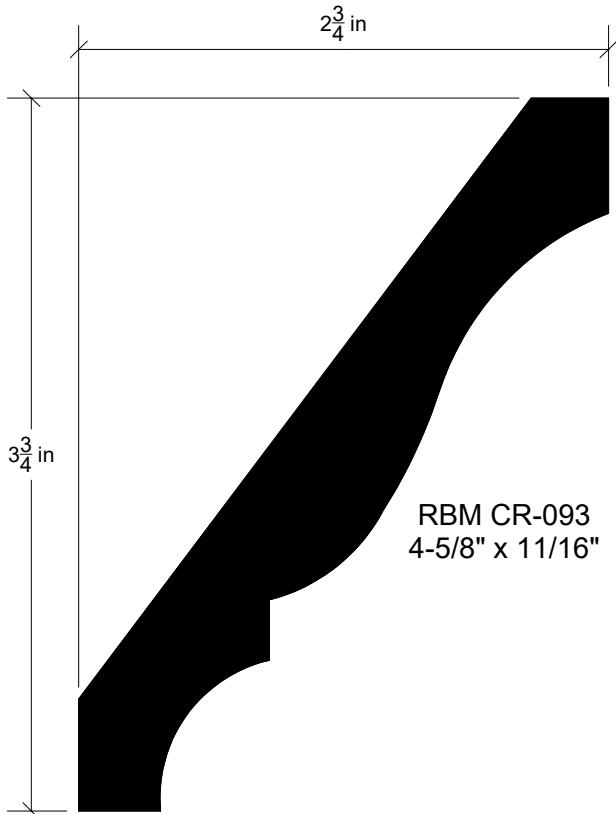

RBM CR-093
4-5/8" x 11/16"

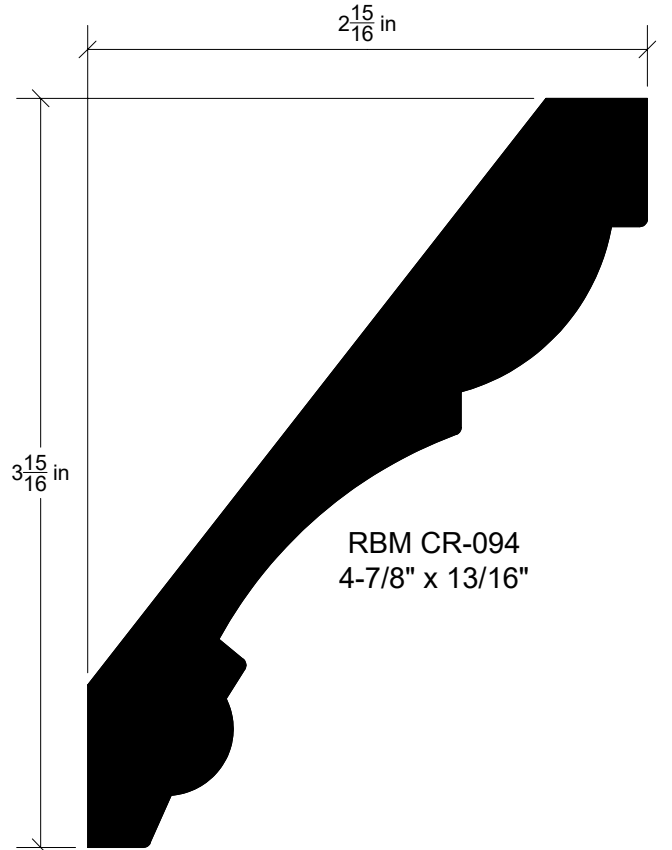

RBM CR-094
4-7/8" x 13/16"

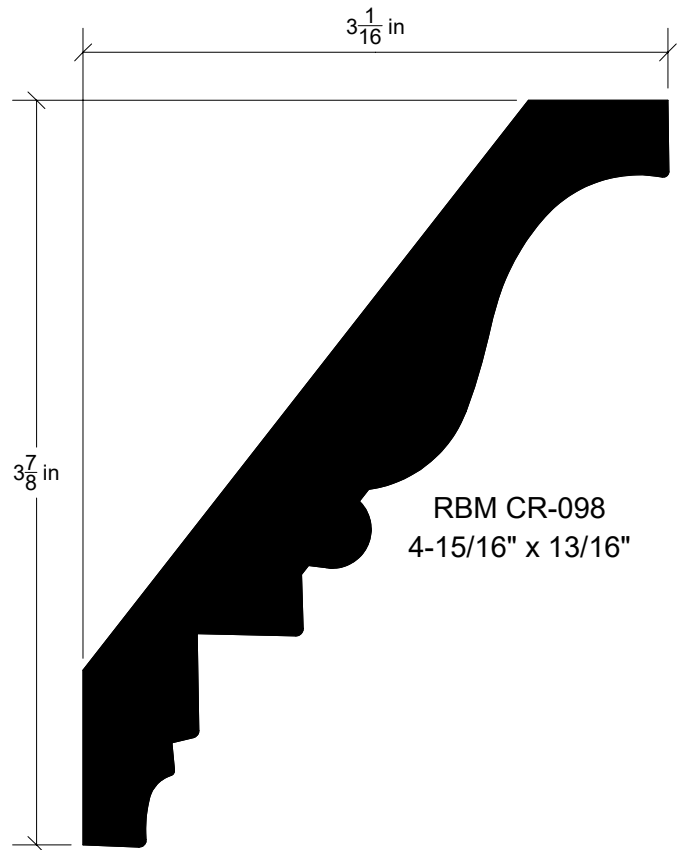
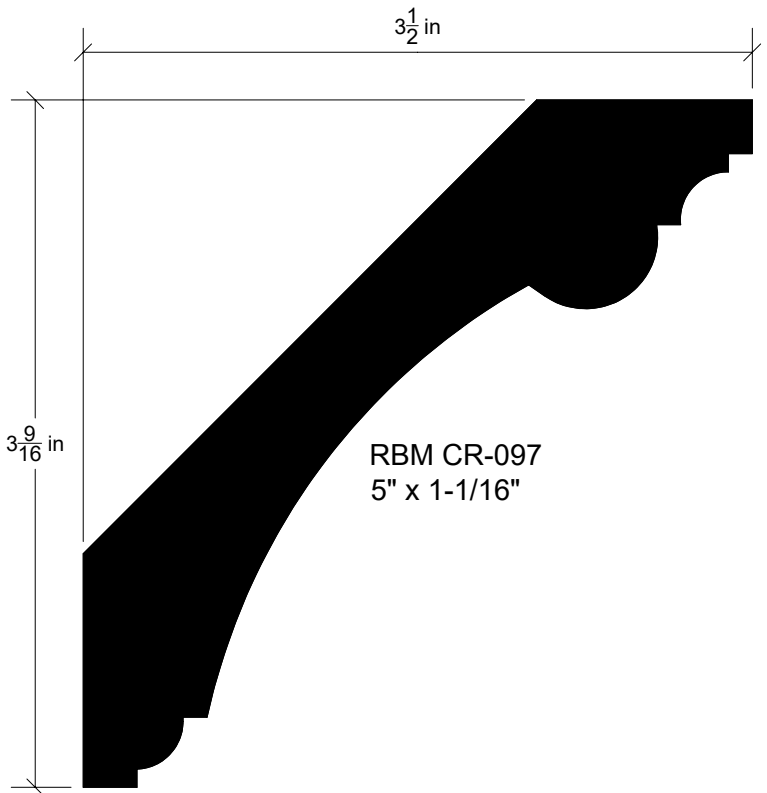
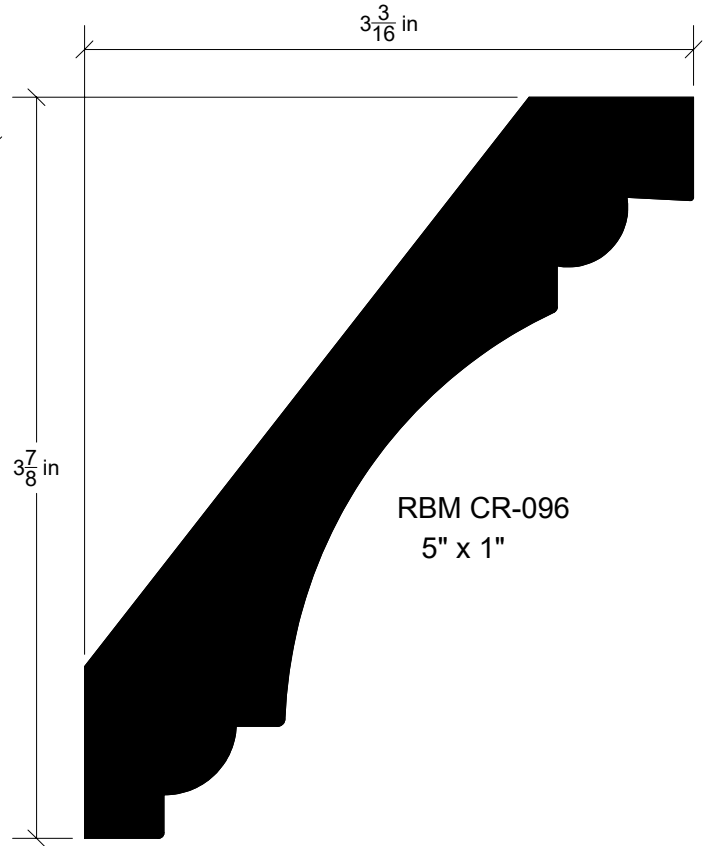
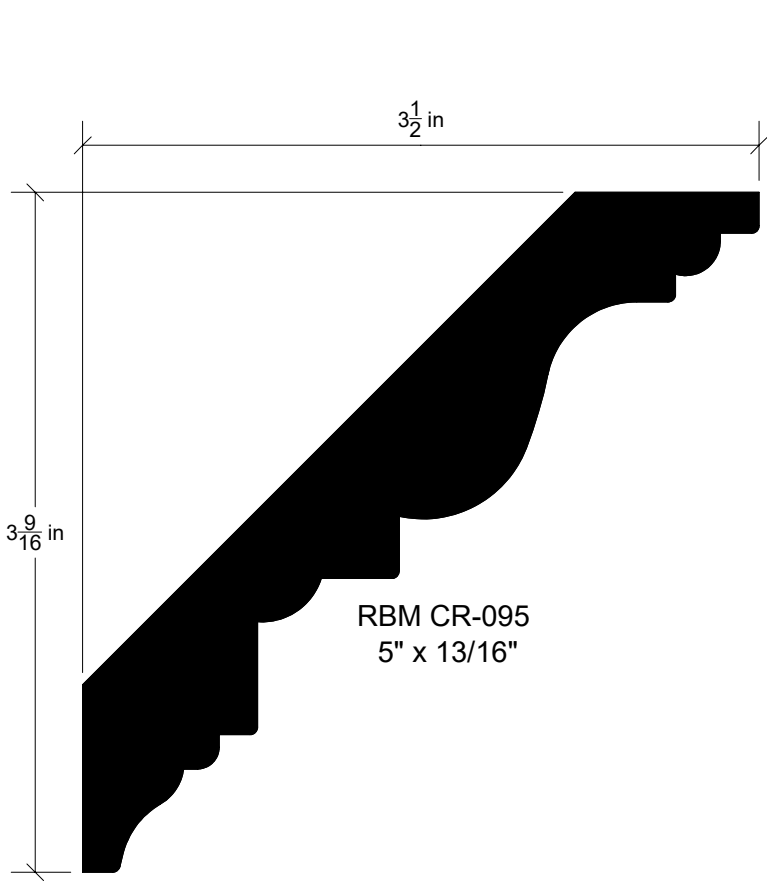

Crowns

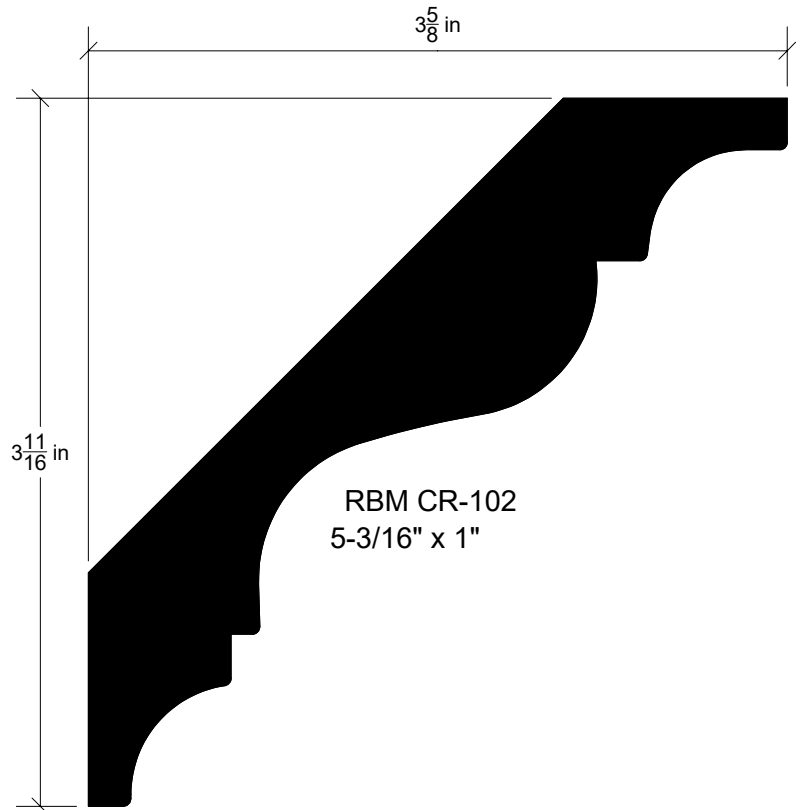
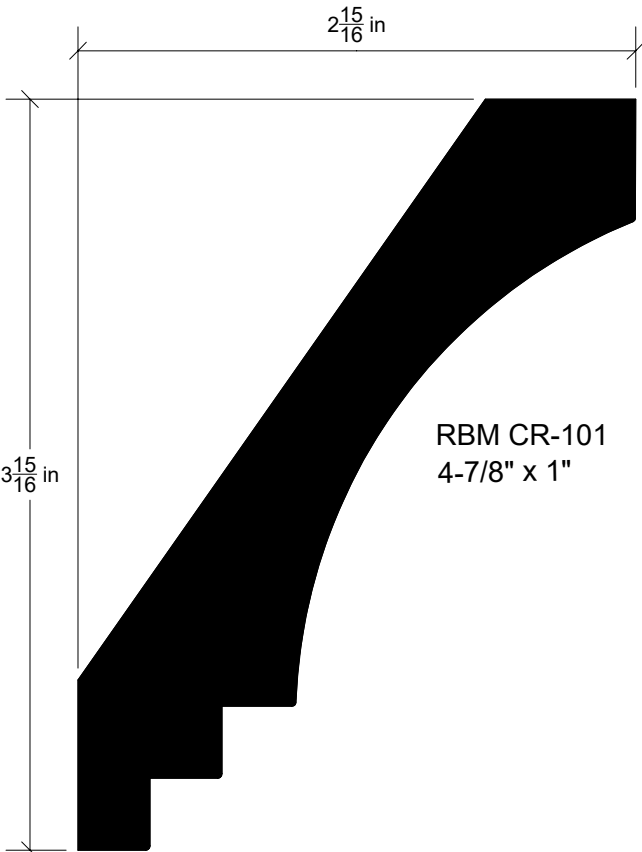
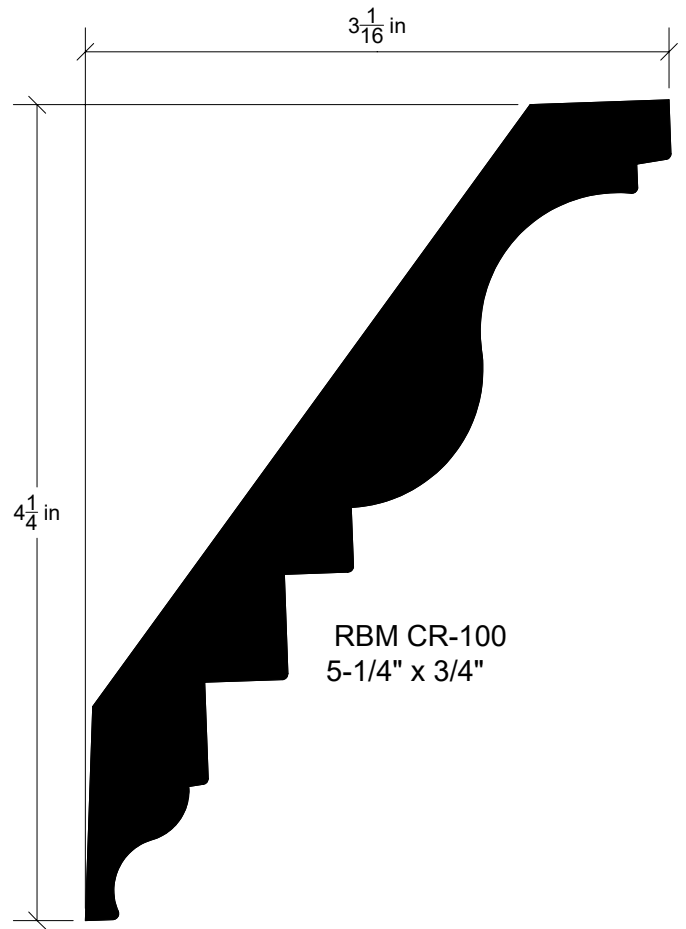
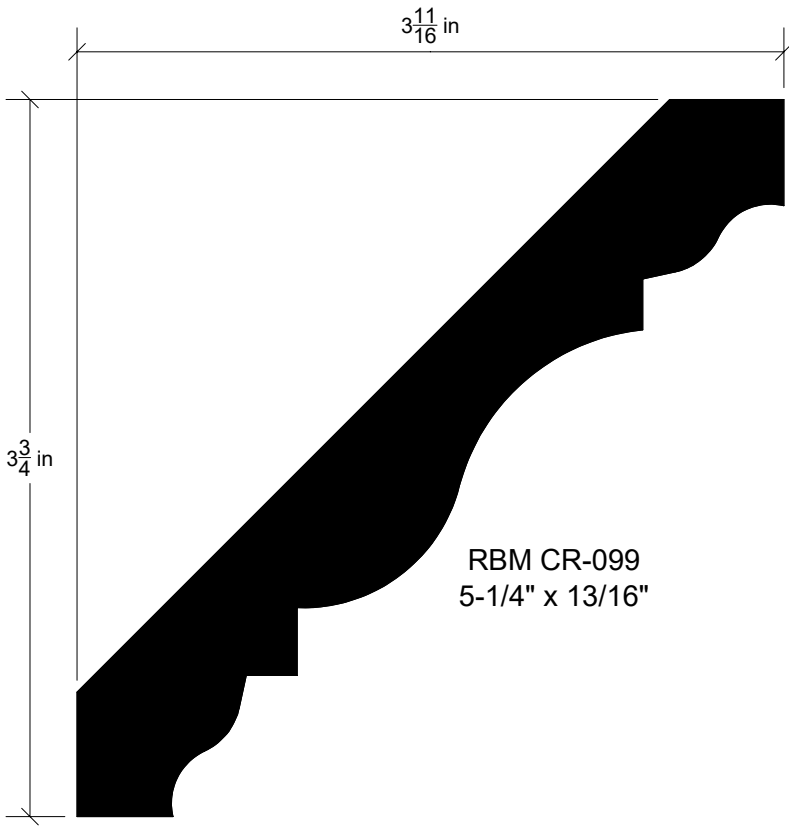

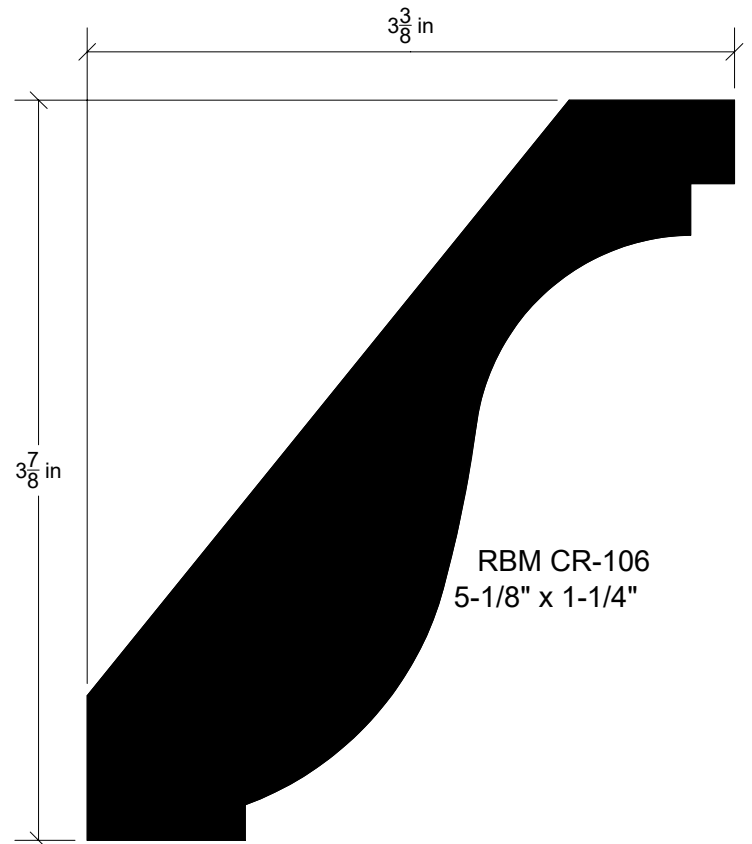
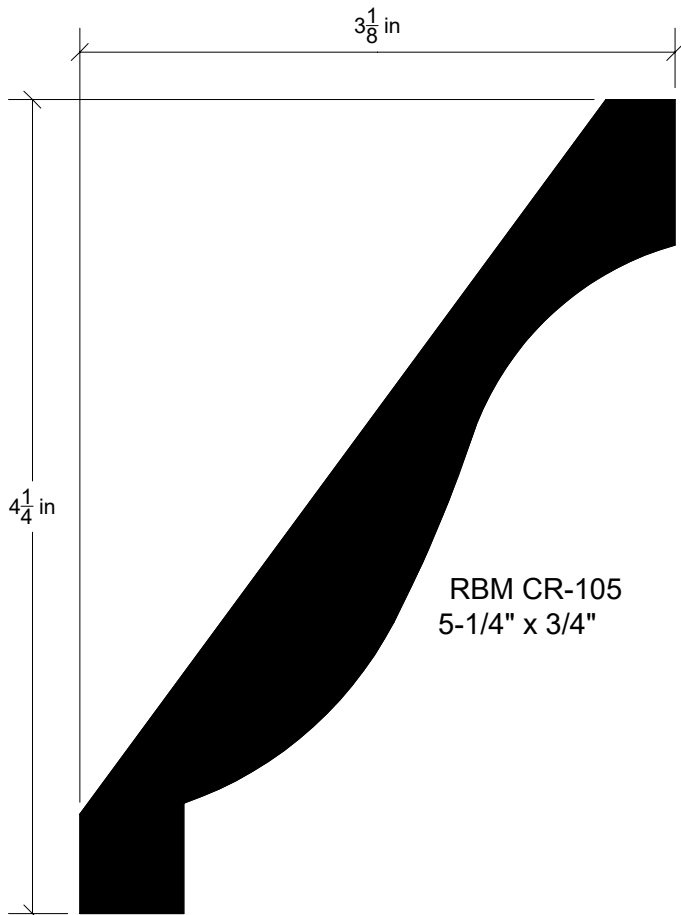
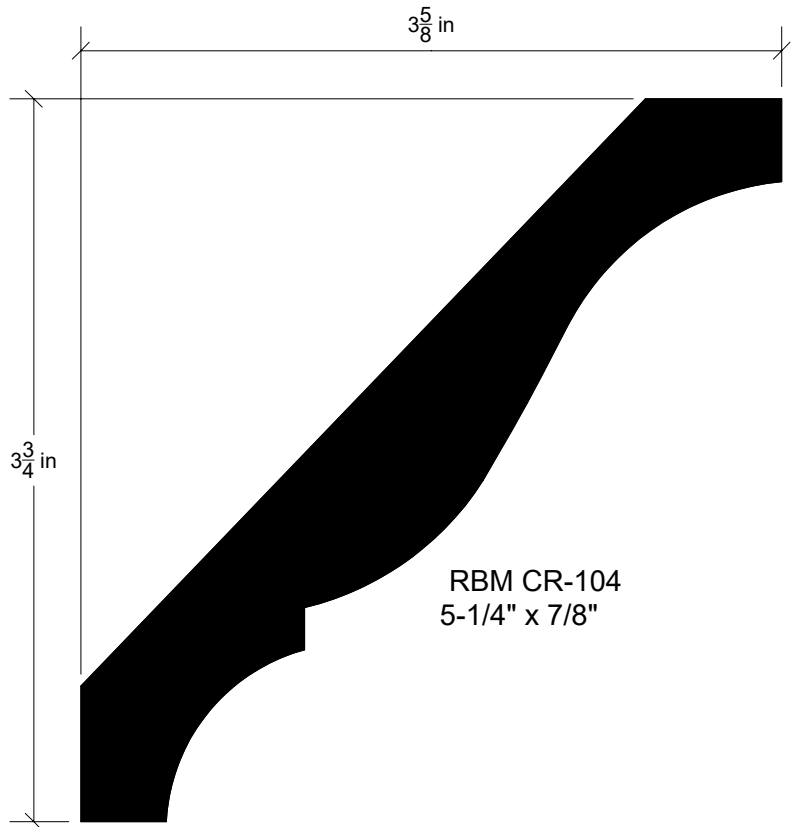
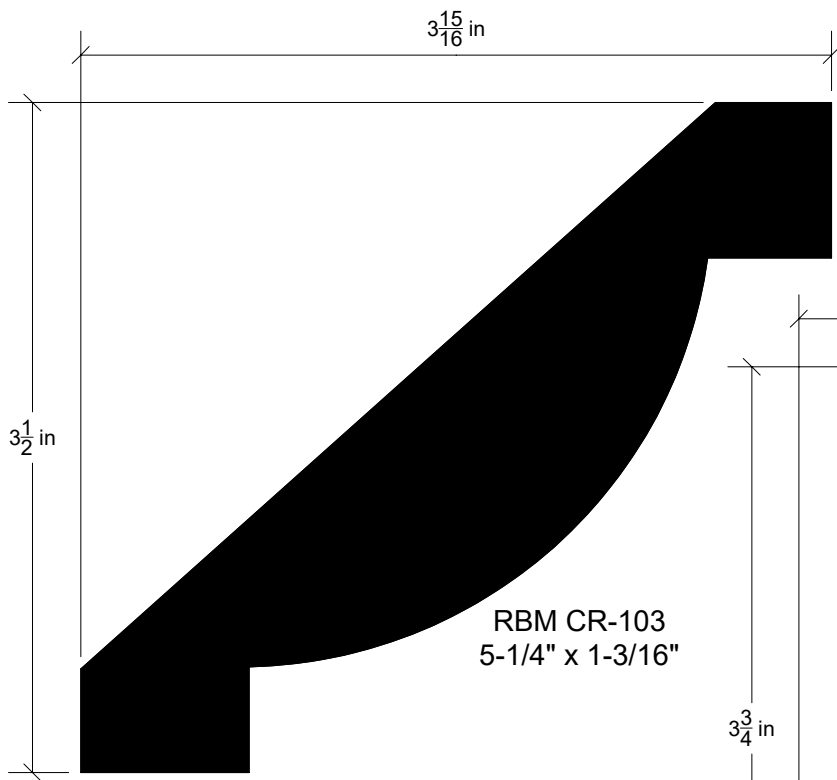

Crowns

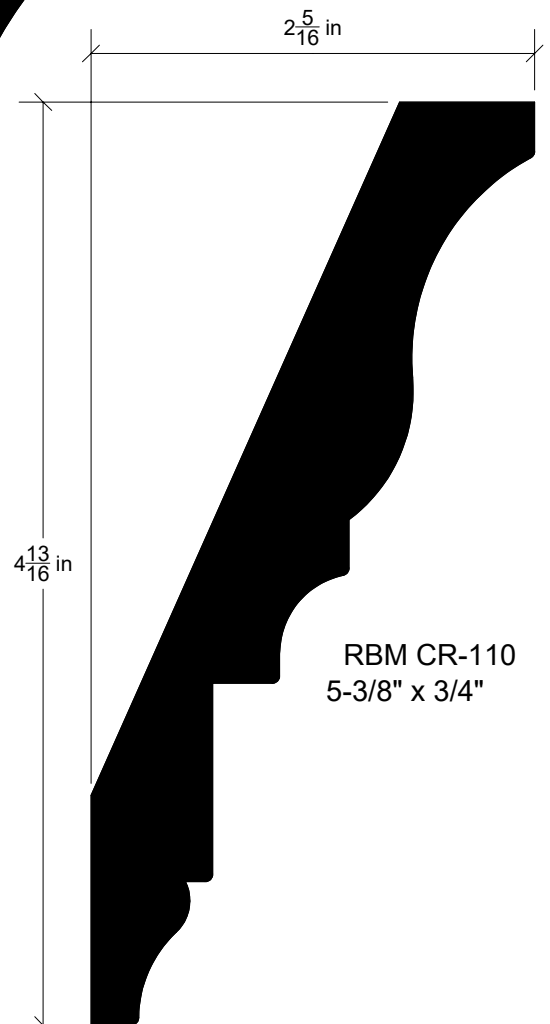
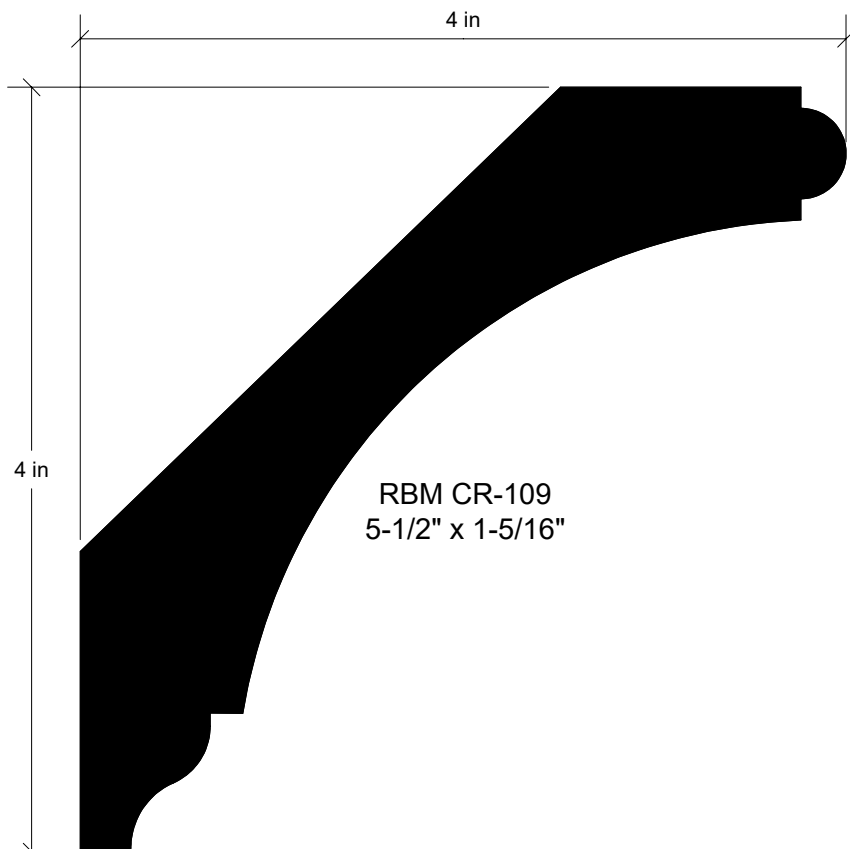
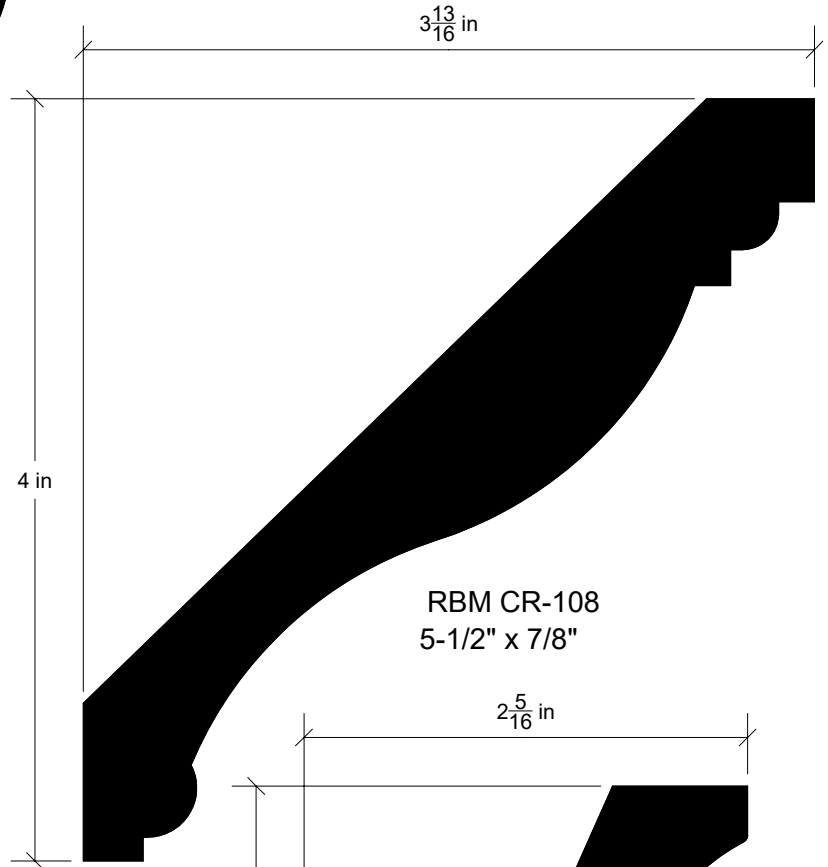
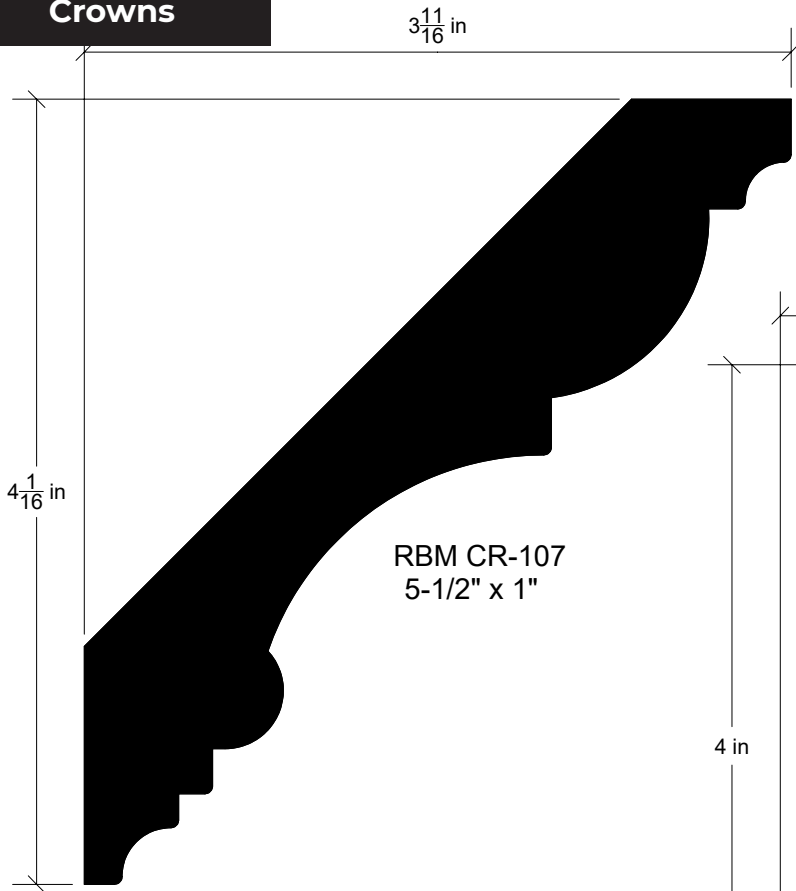

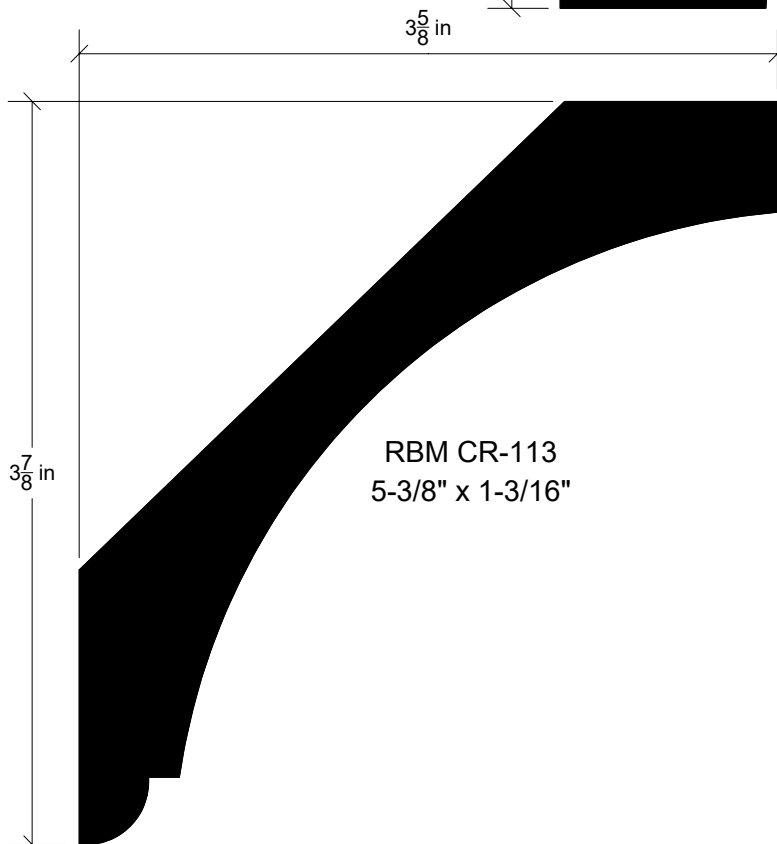
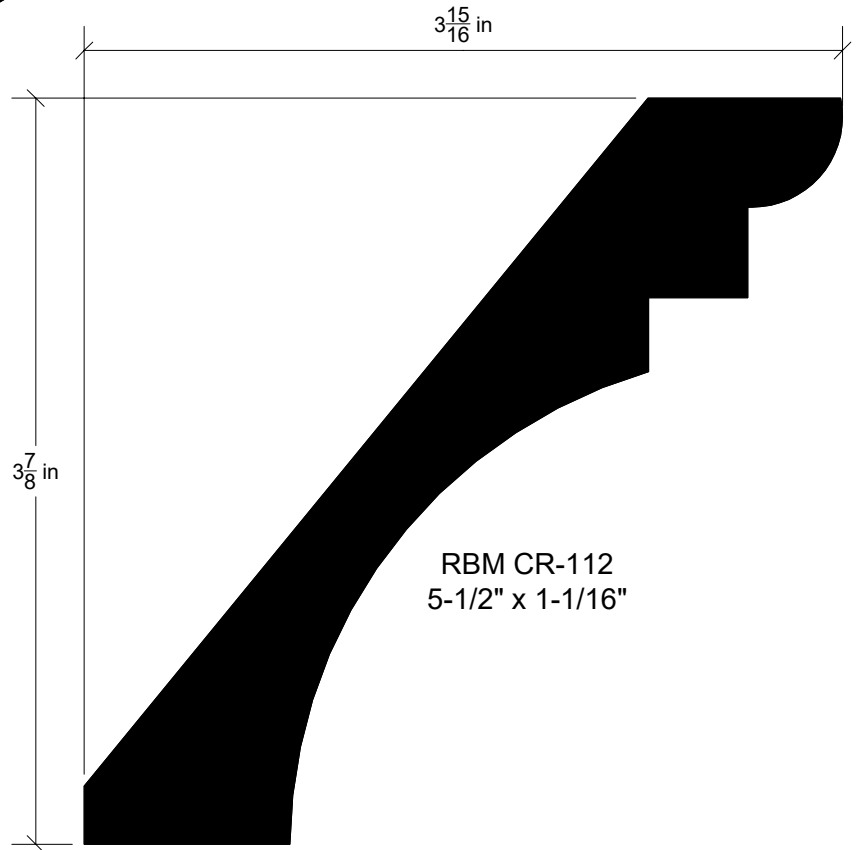
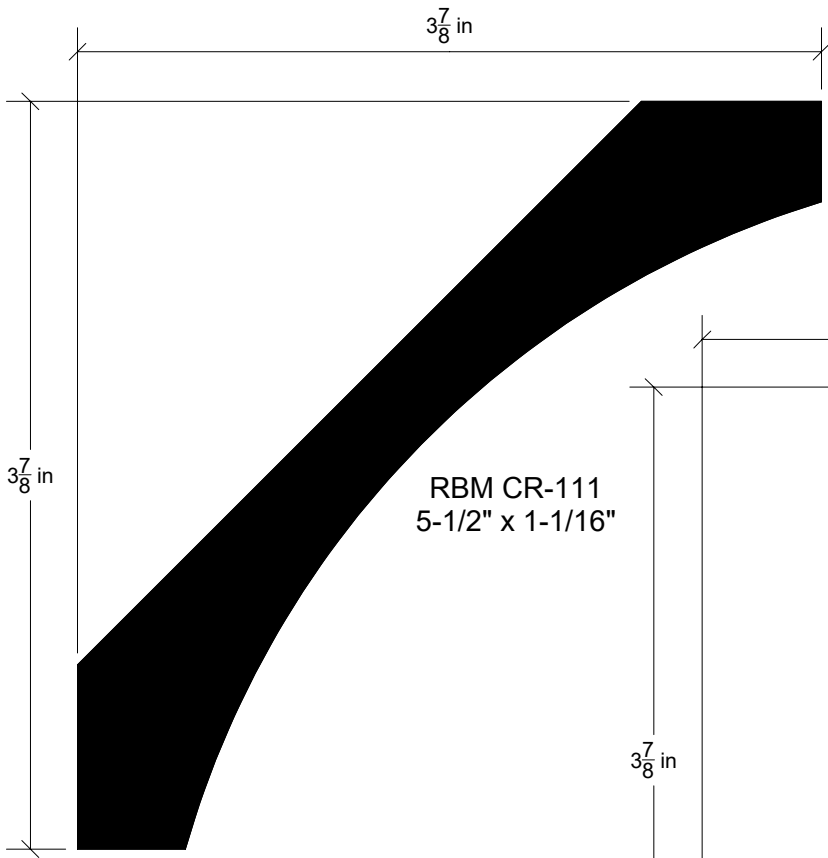

Crowns

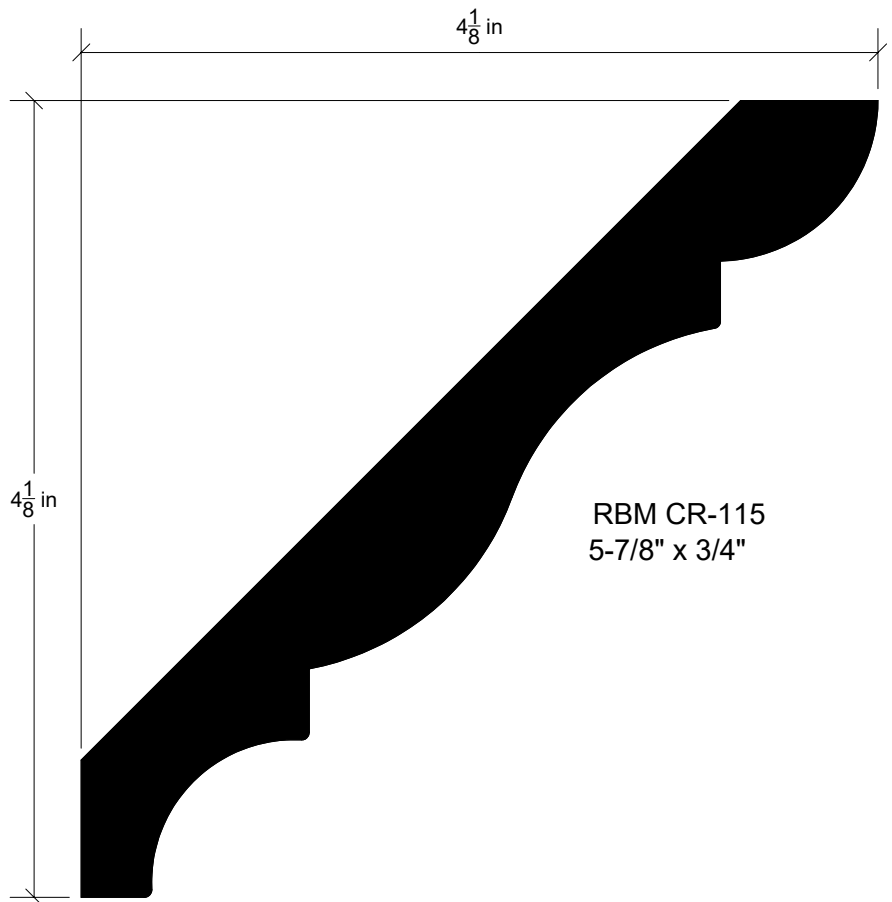
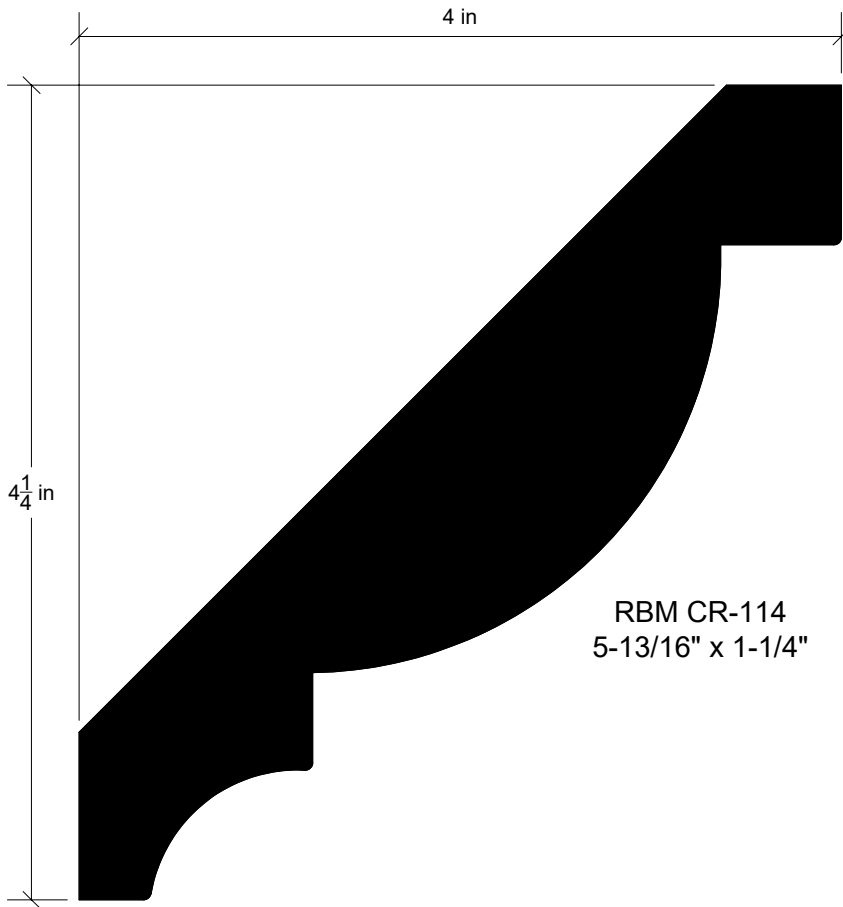

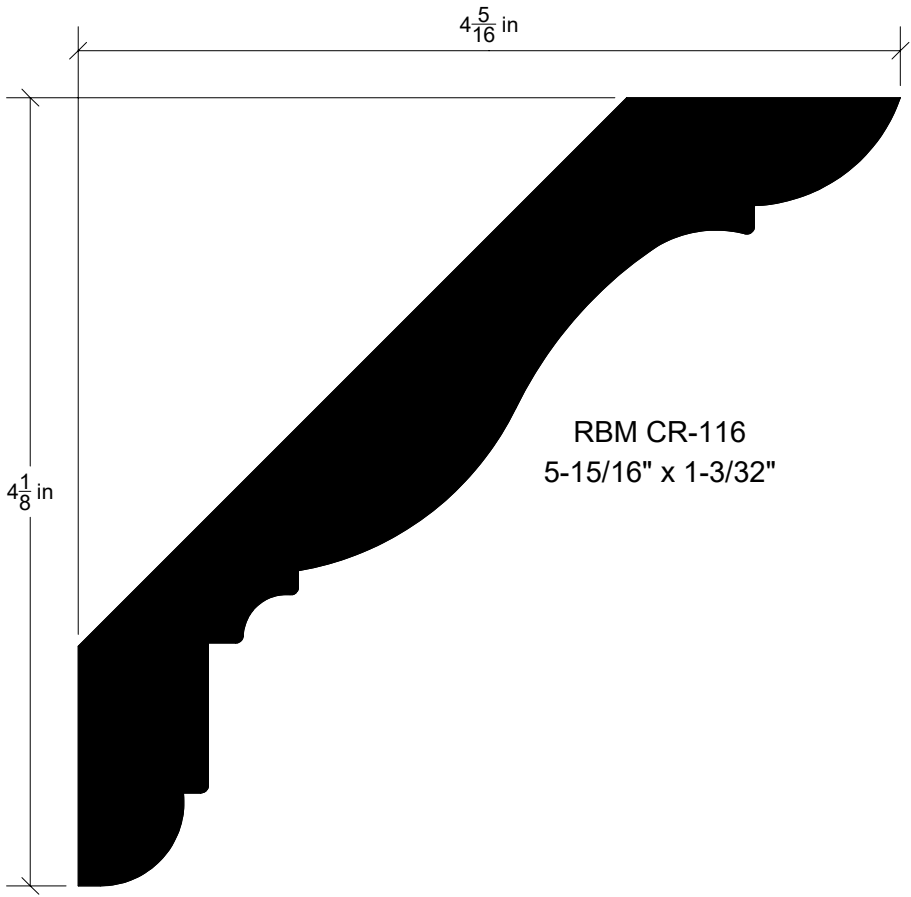

RBM CR-116
5-15/16" x 1-3/32"

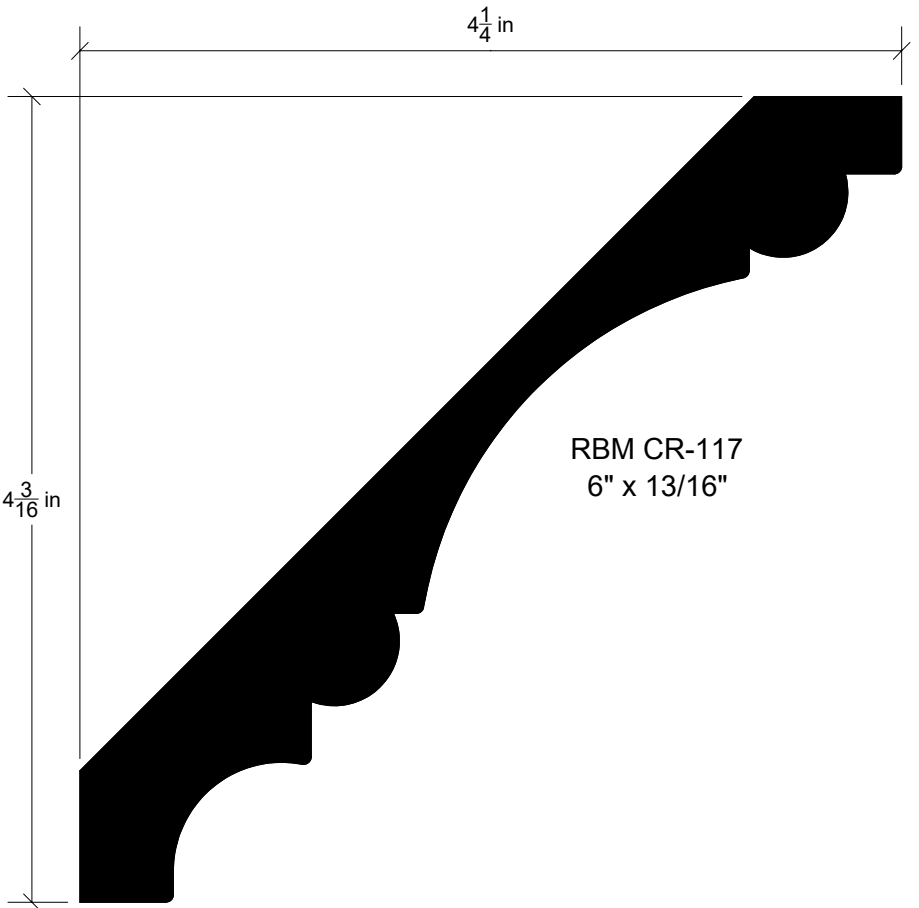

RBM CR-117
6" x 13/16"

Crowns

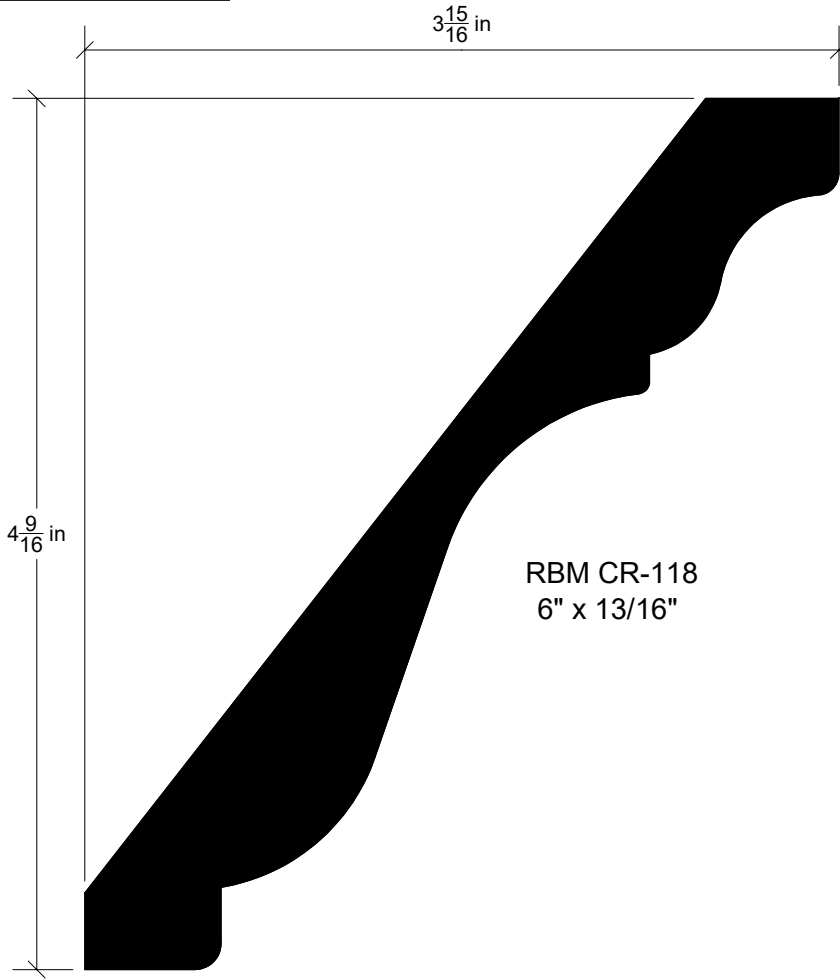

RBM CR-118
6" x $13\frac{1}{16}$ "

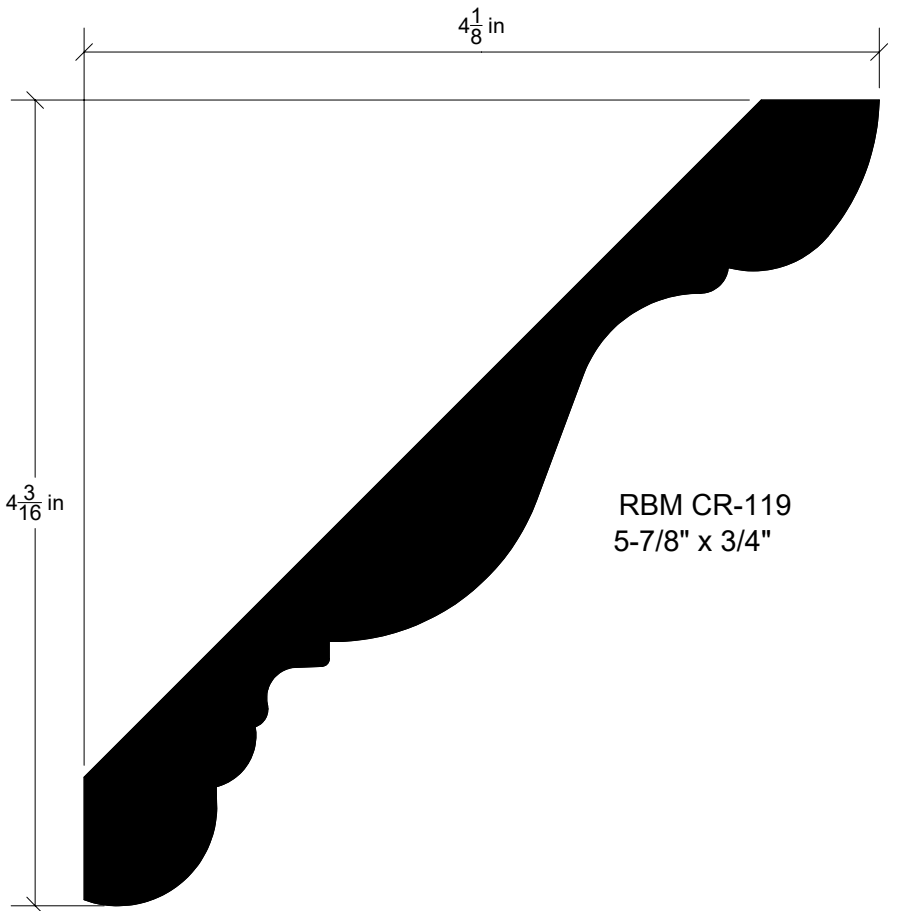

RBM CR-119
5-7/8" x $3\frac{1}{4}$ "

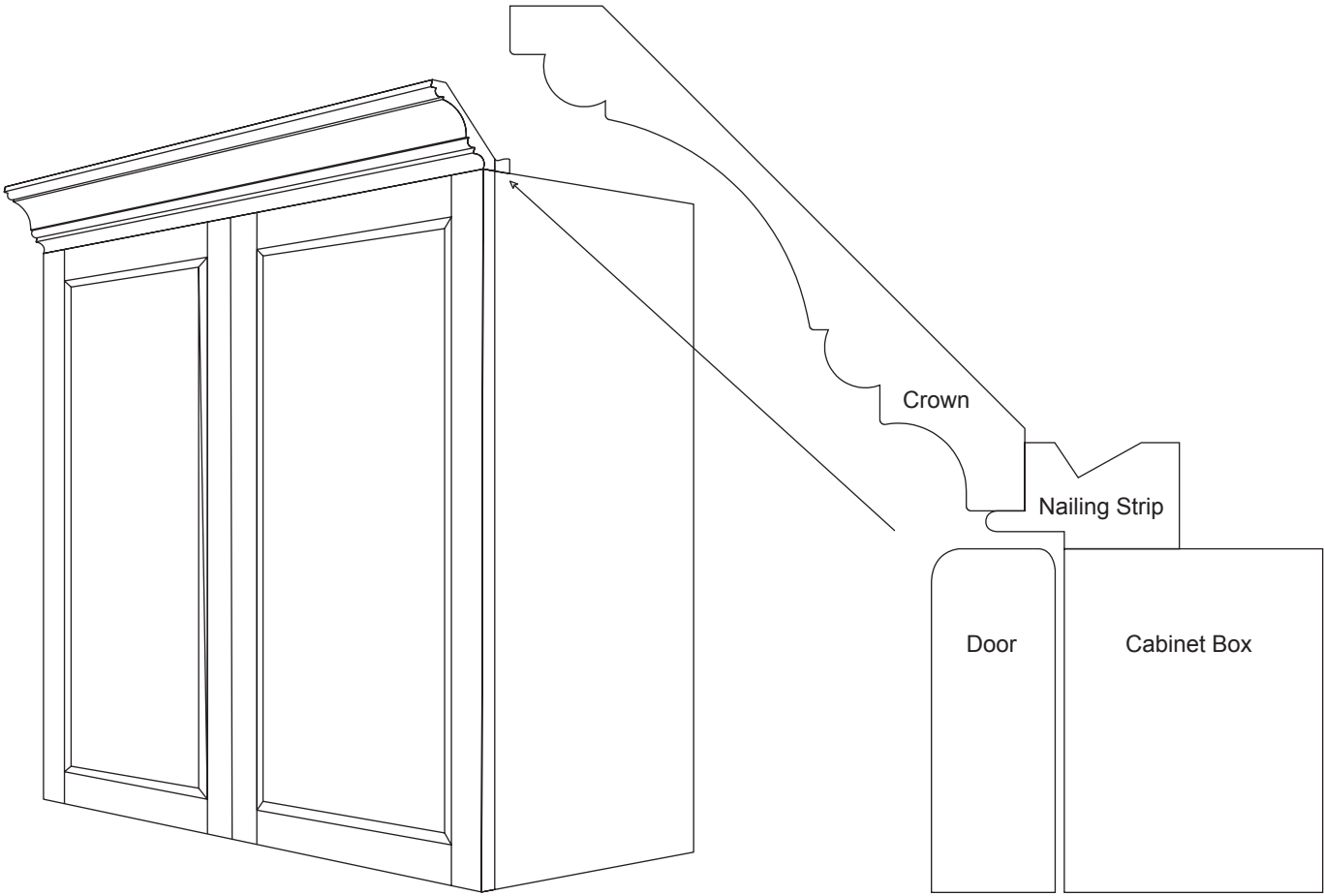

RBM NS-1

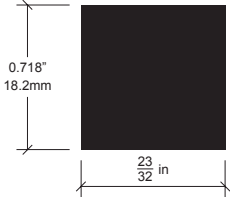

RBM NS-2

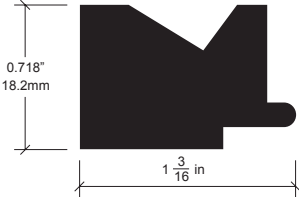

RBM NS-3

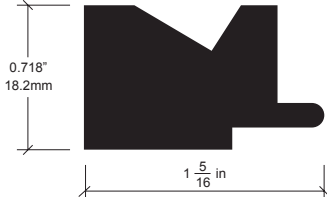

RBM NS-4

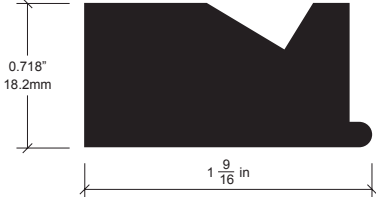

FLAT FACE BASEBOARDS

MOST POPULAR

Edge Guide

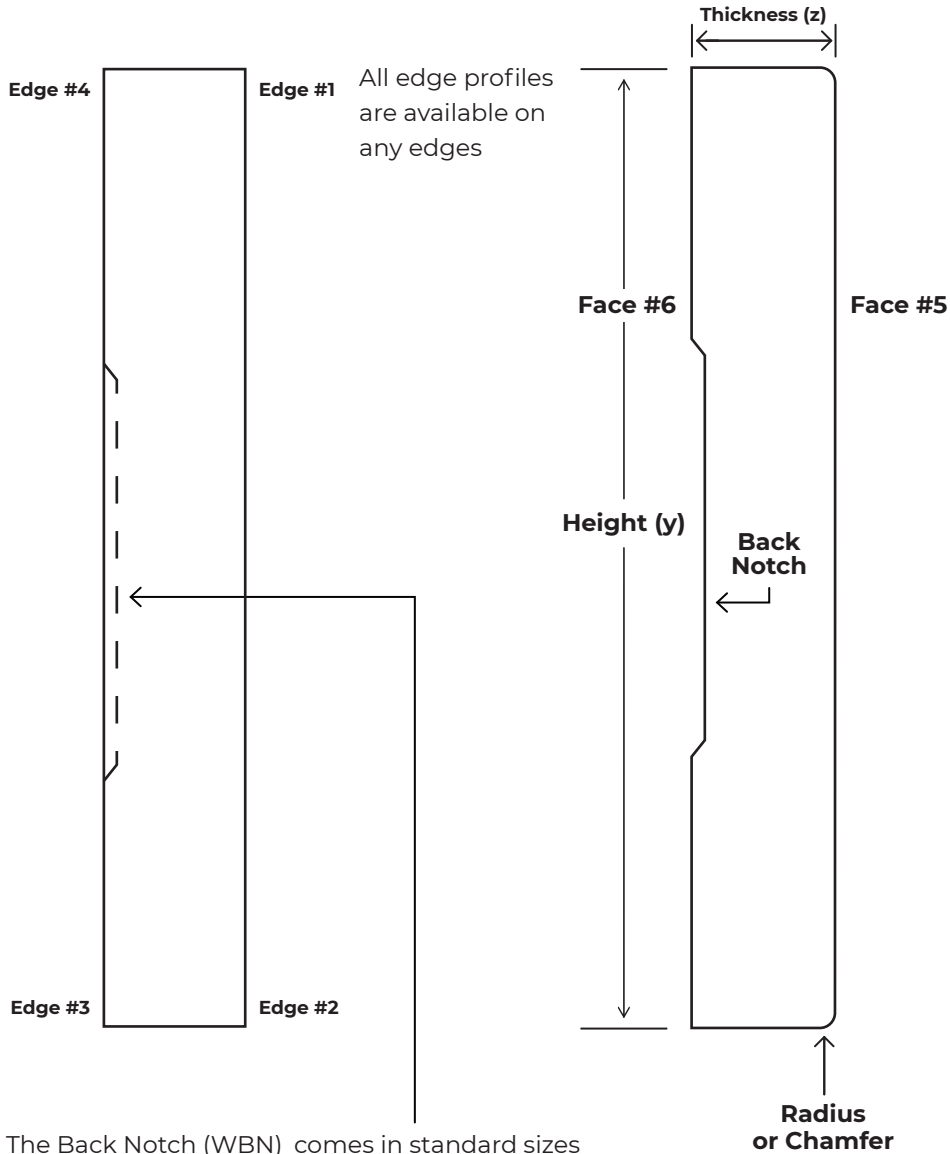

When providing us with specifications for your made-to-order baseboards, please refer to the diagram to the left. Please note (y) and (z) values. Chamfered corner requests or radius of eased edge required.

See pages 36-38 for radius & chamfer guides.

Most Popular Heights

Inch	MM
2	50.8
2.25	57.15
2.5	63.5
2.75	69.85
3	76.2
3.25	82.55
3.5	88.9
3.625	92.07
3.75	95.25
4	101.6
4.25	107.95
4.5	114.3

Most Popular Thicknesses

Inch	MM
7/16	11.11
1/2	12.7
9/16	14.29
5/8	15.87
3/4	19.05

The Back Notch (WBN) comes in standard sizes to match the size of your baseboard. Custom **Back Notch (WBN)** sizes are available on request but will be subject to a tooling fee. Call us for more information

POPULAR SIZE COMBINATIONS

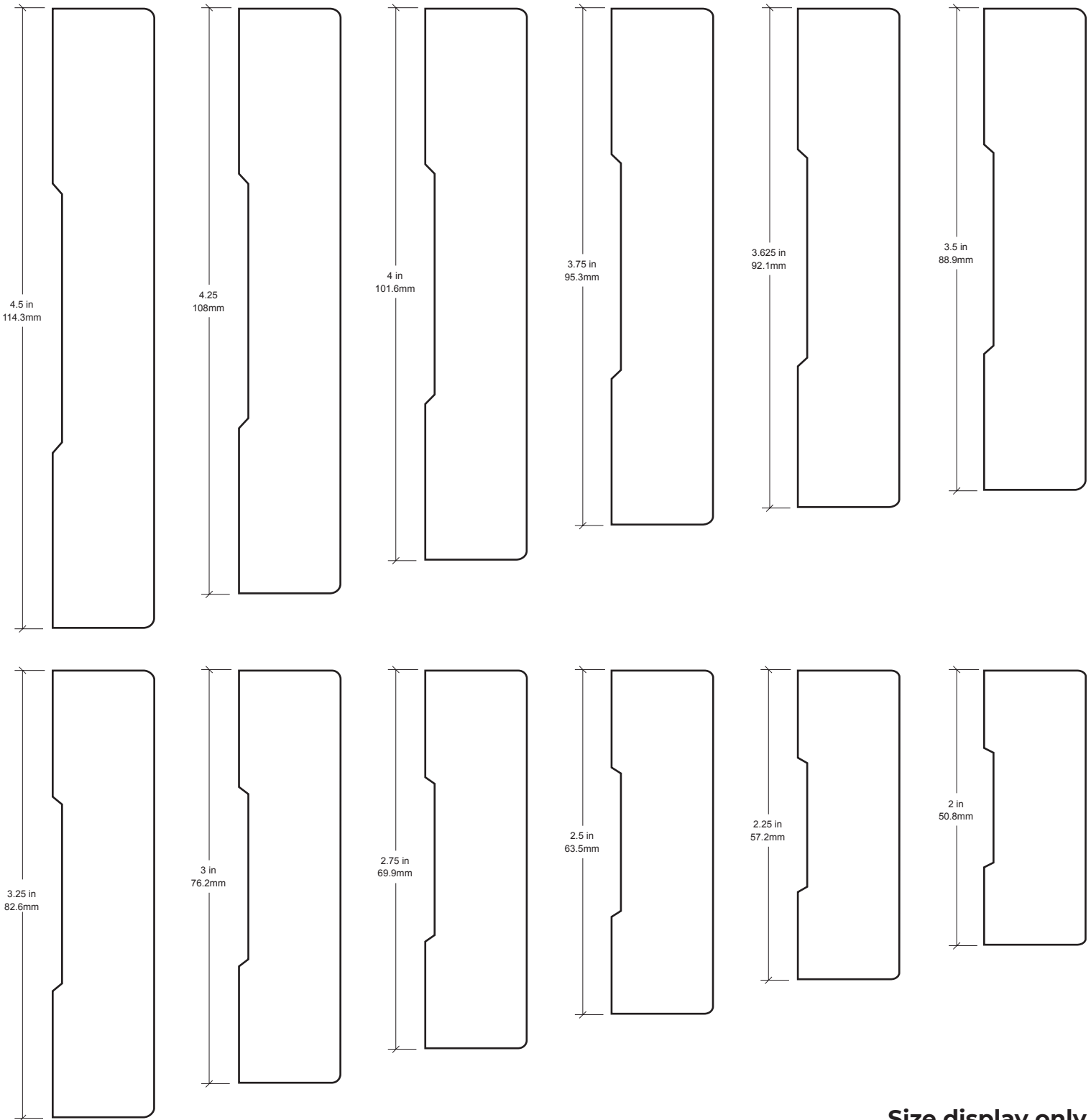

Size display only
Back notch is optional

POPULAR SIZE COMBINATIONS

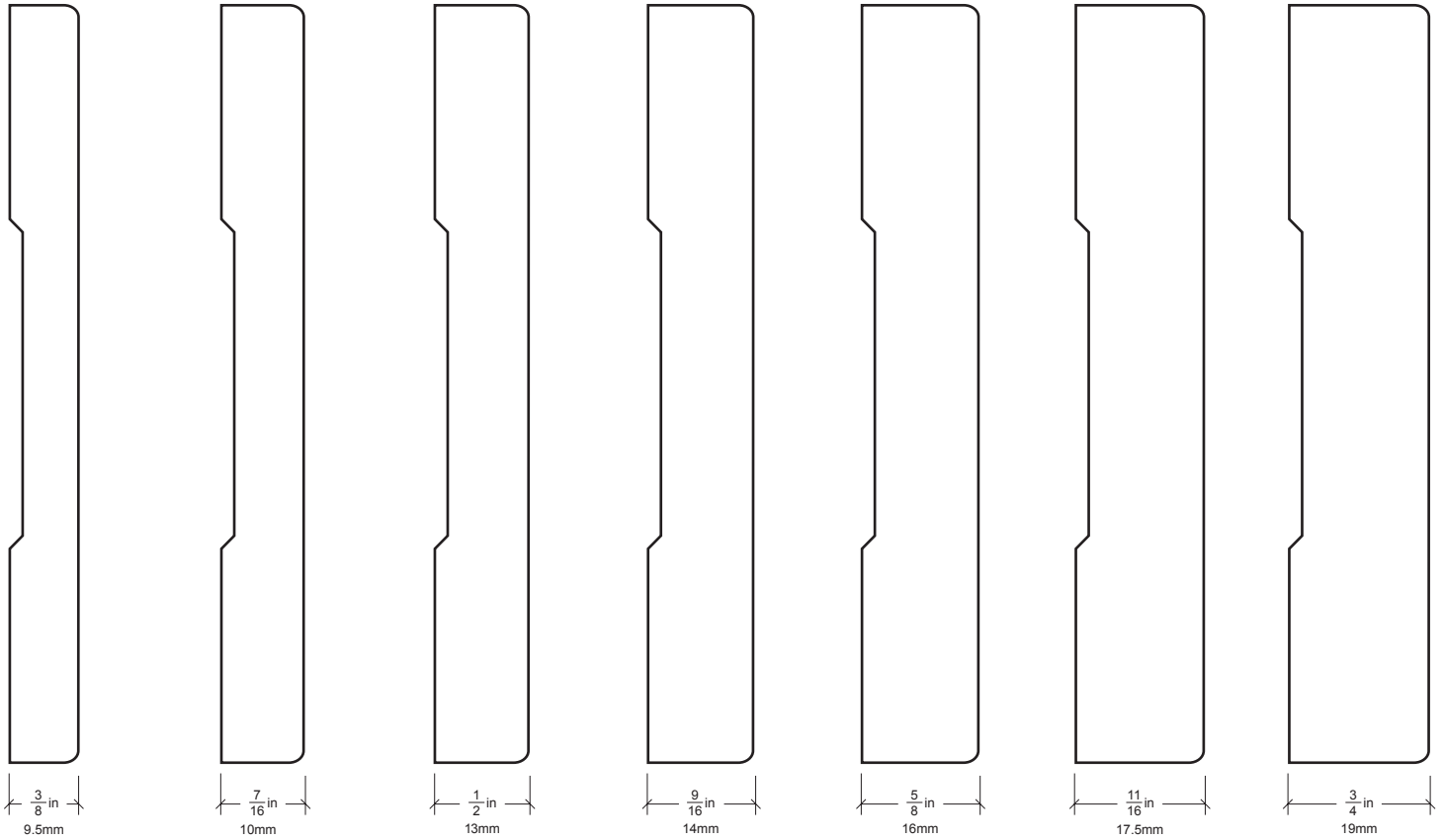

Size display only
Back notch is optional

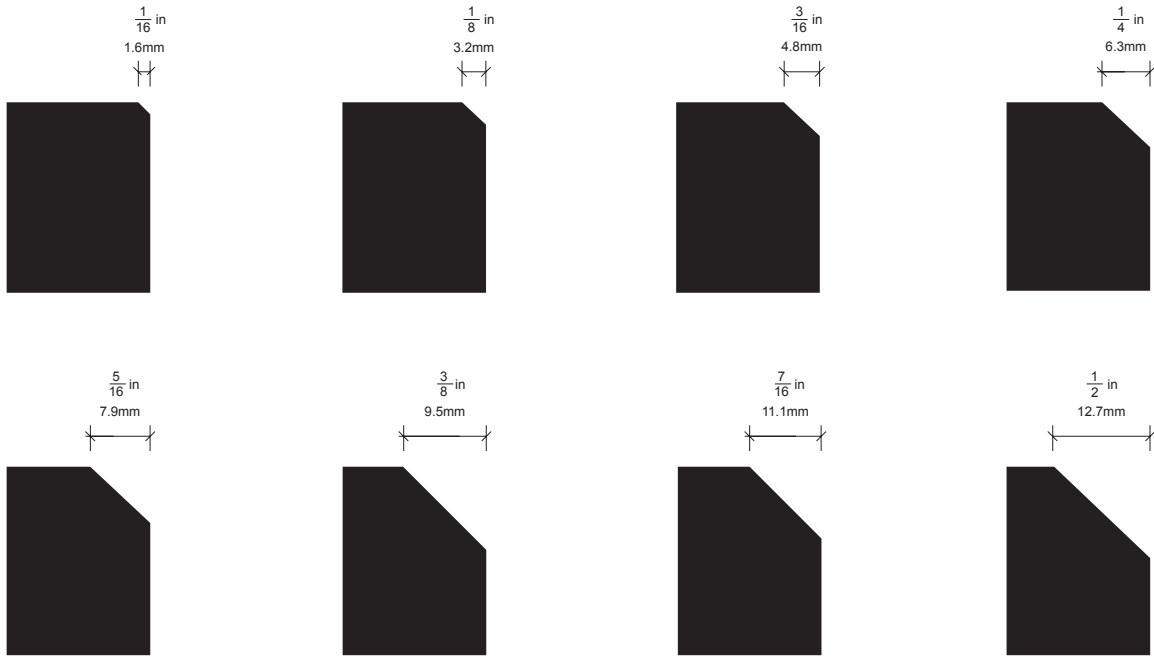

Radius Guide

Imperial/Metric

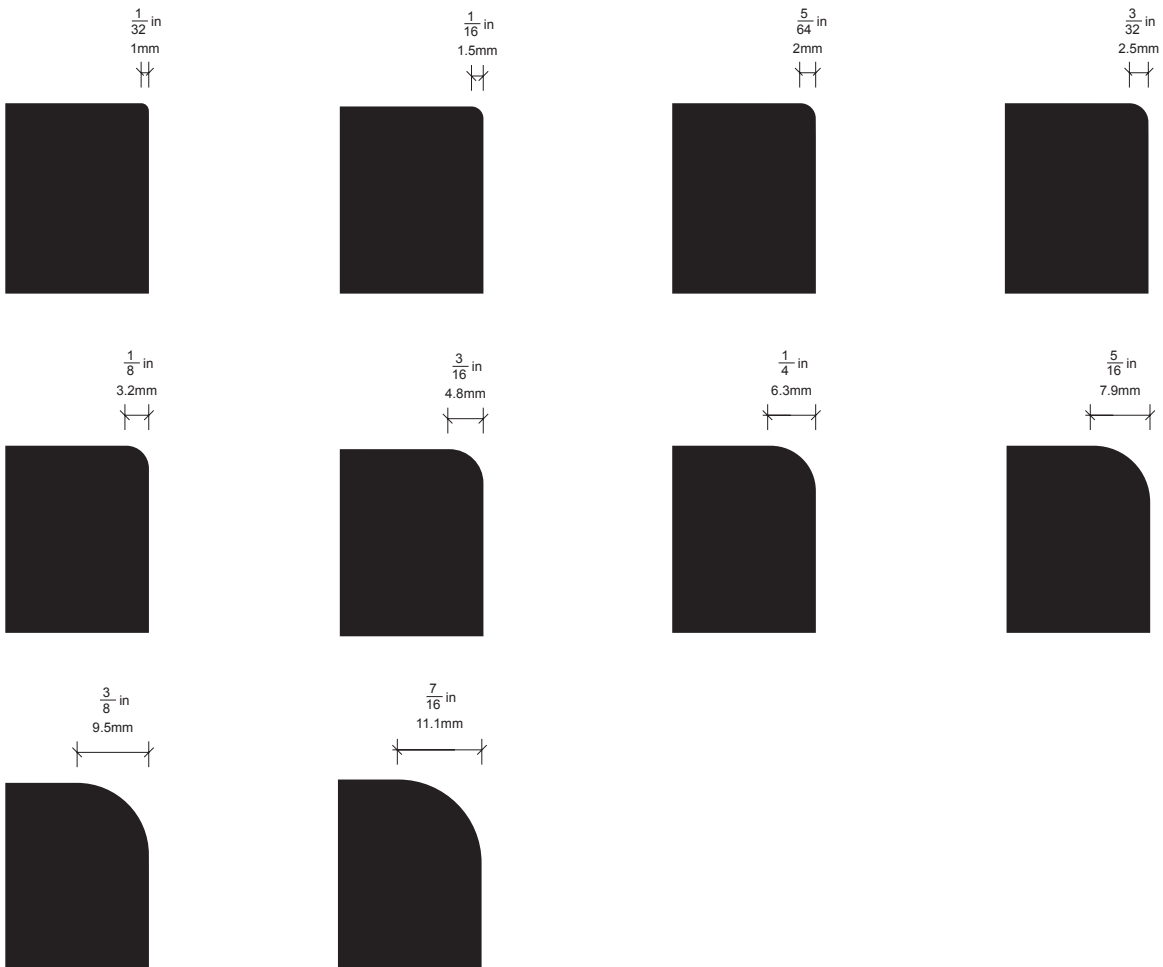

Baseboards

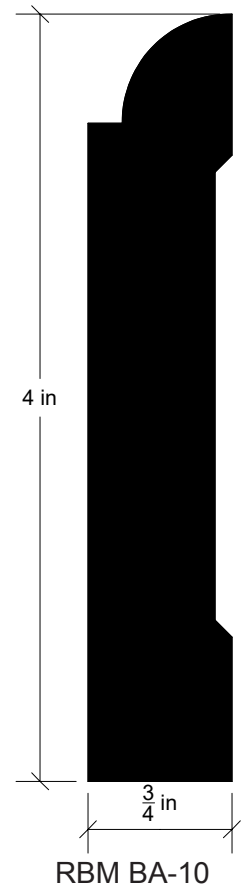
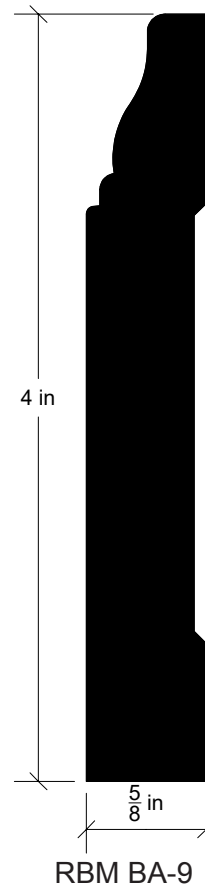
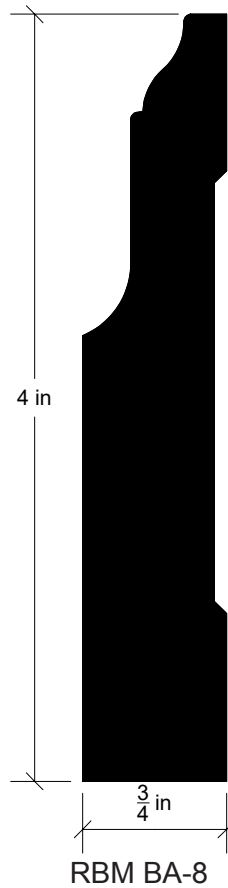
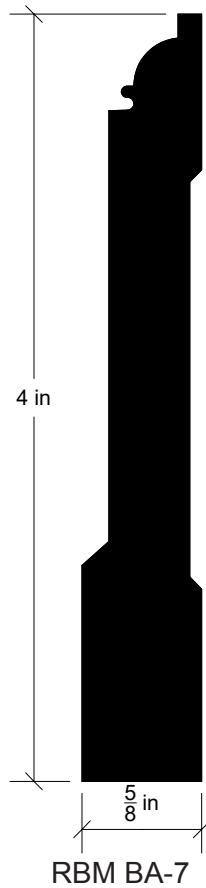
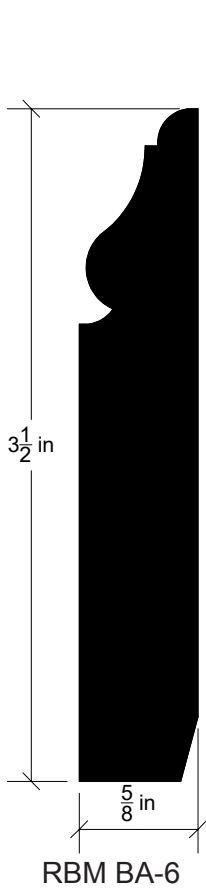
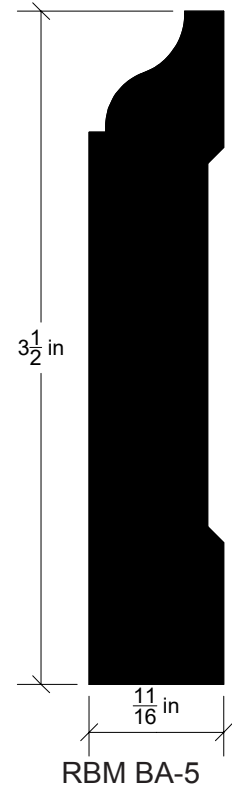
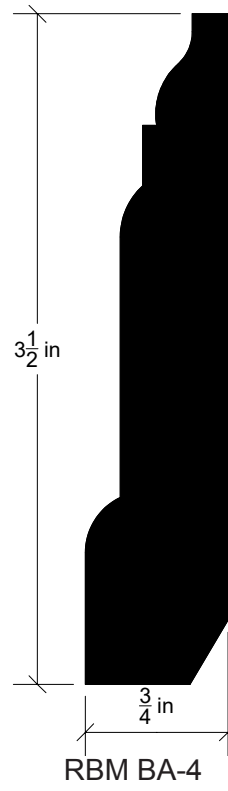
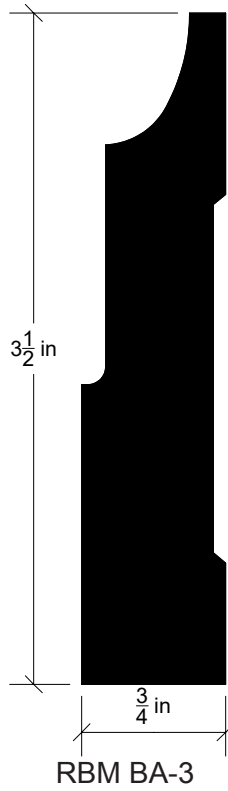
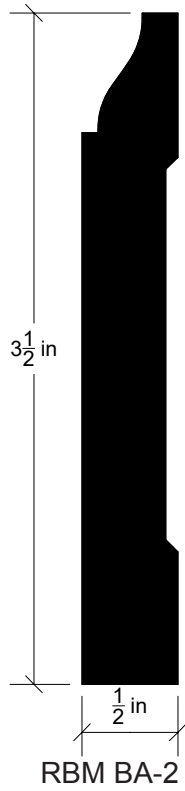
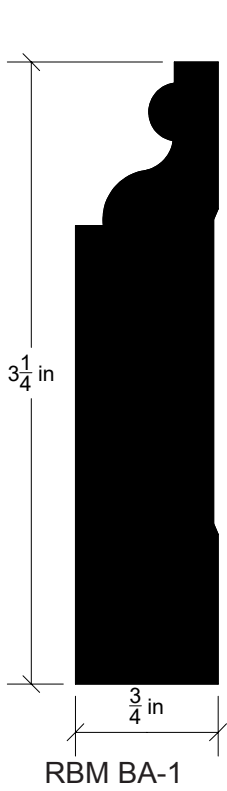

Baseboards

Height and thickness can be changed to your specifications, Let us know what you need!

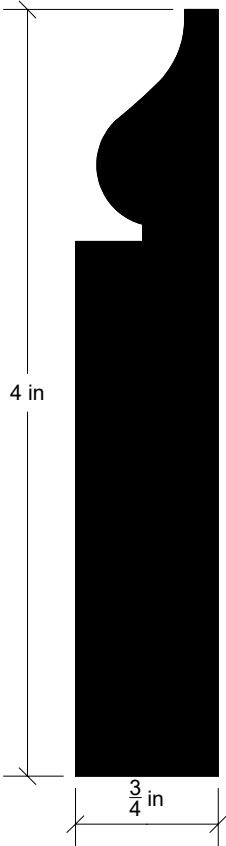

RBM BA-11

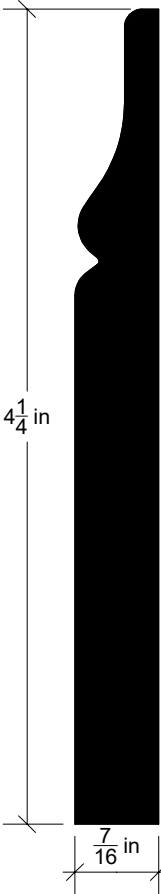

RBM BA-12

MOST POPULAR

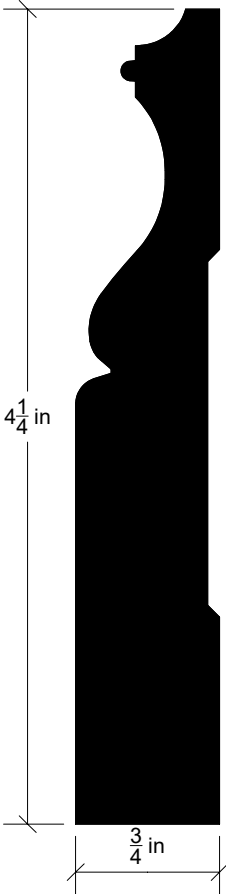

RBM BA-13

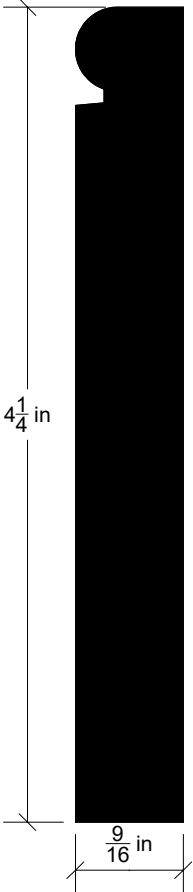

RBM BA-14

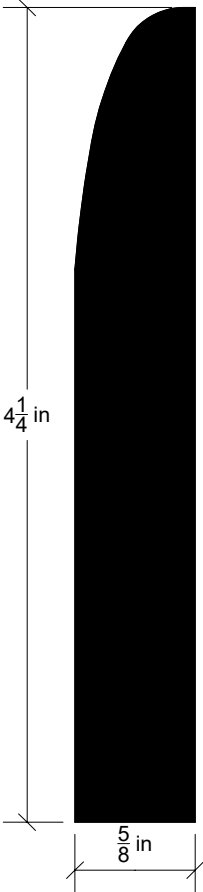

RBM BA-15

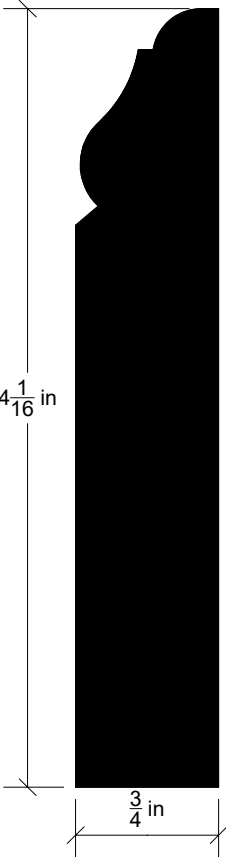

RBM BA-16

Baseboards

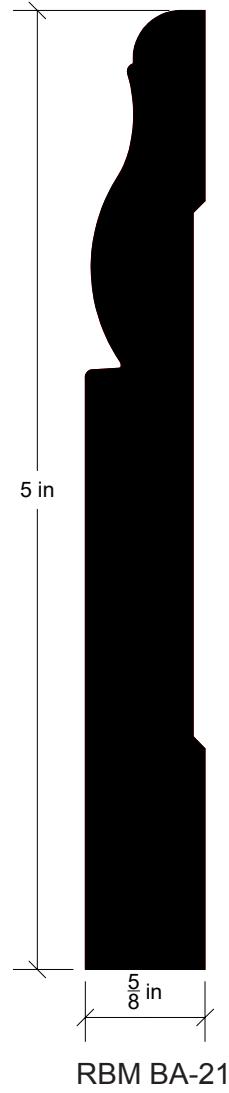
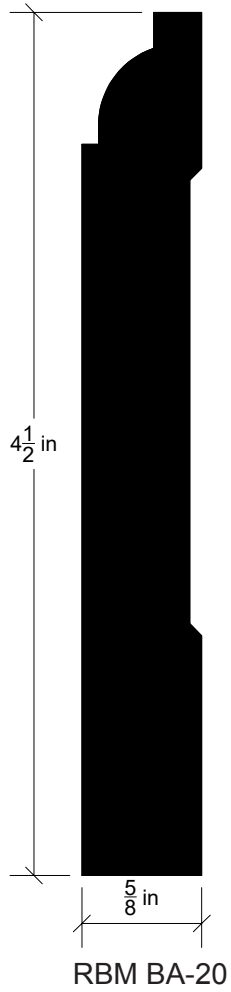
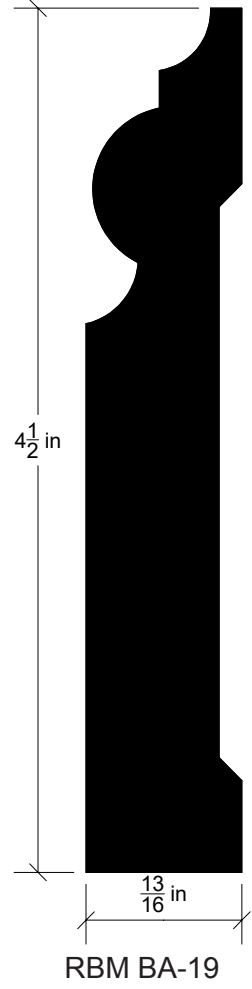
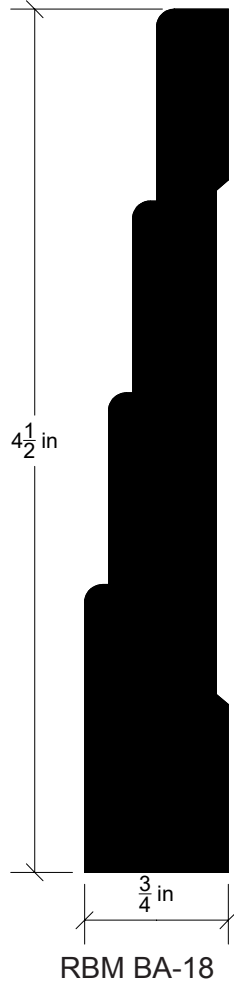
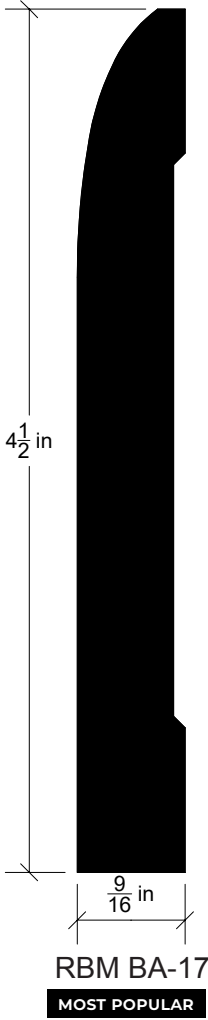

Baseboards

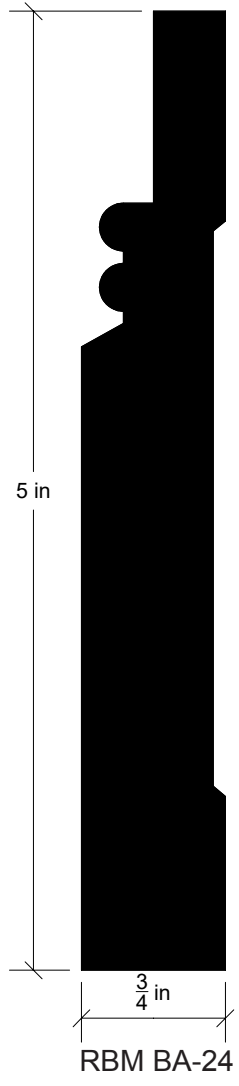
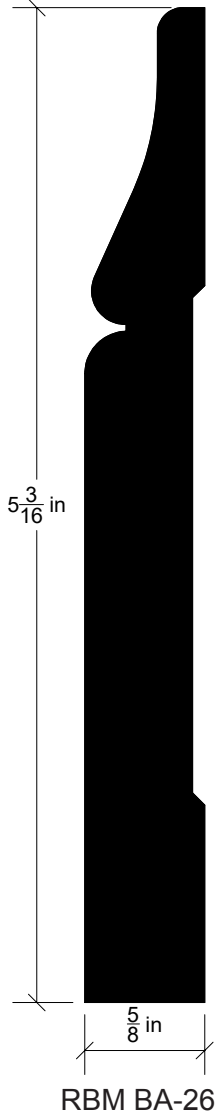
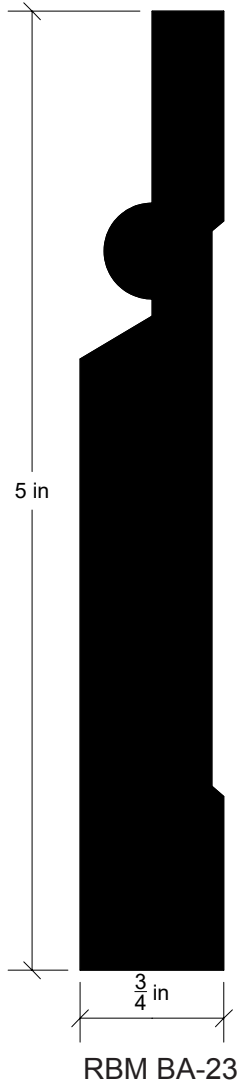
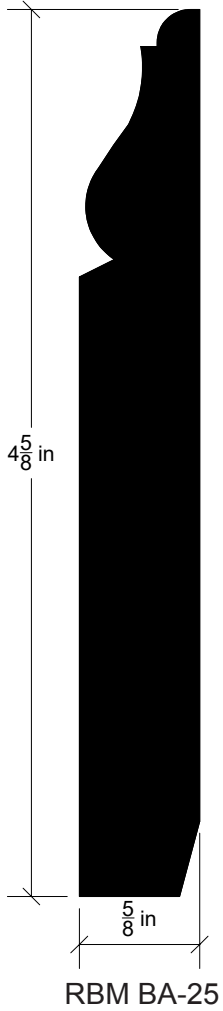
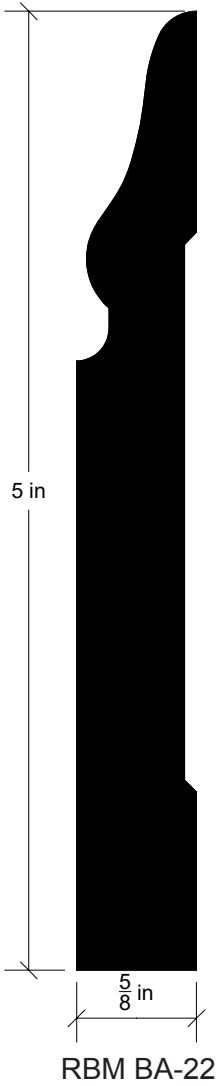

Baseboards

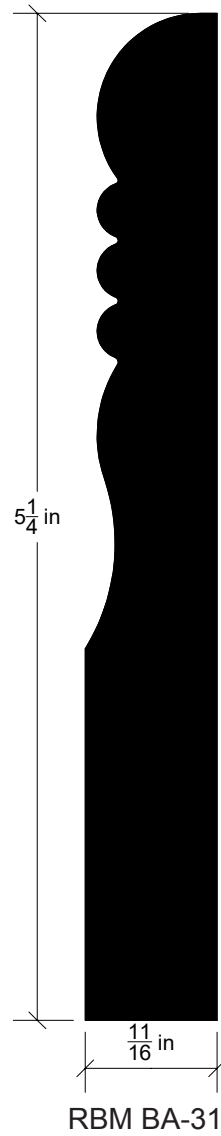
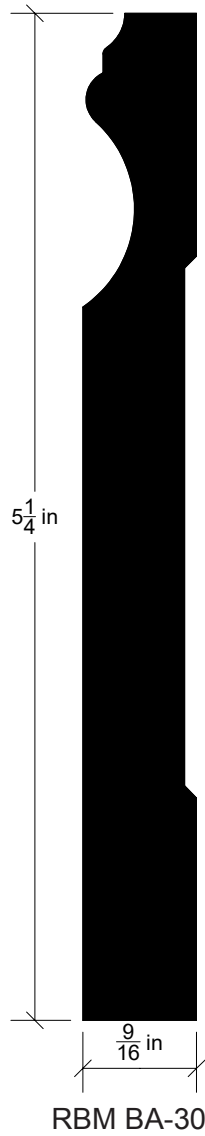
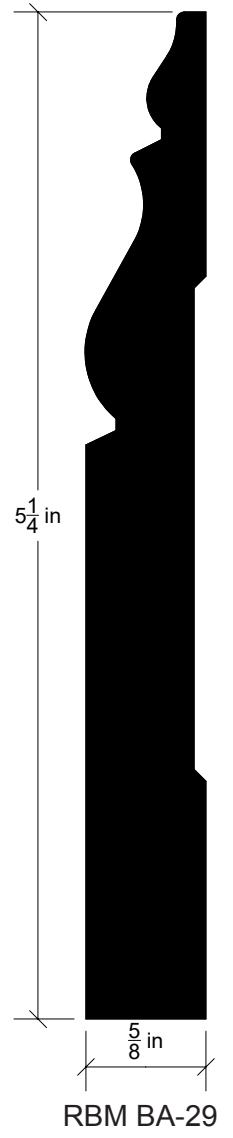
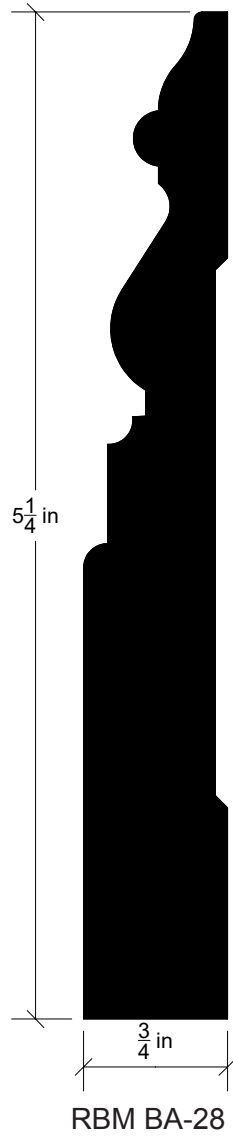
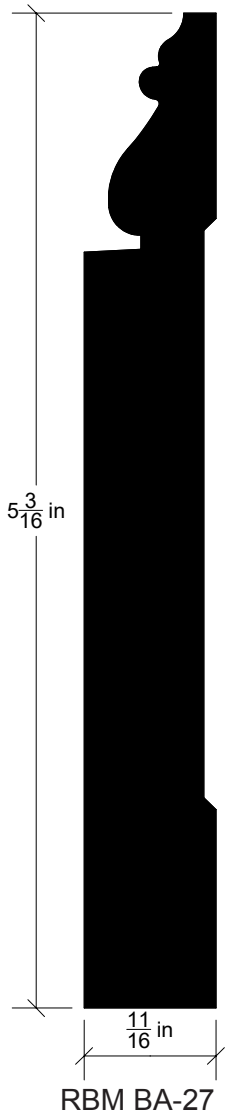

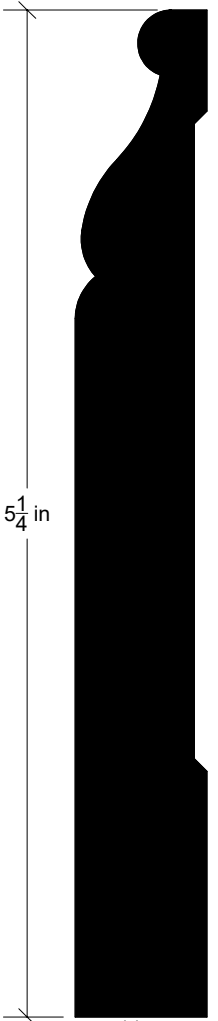

RBM BA-32

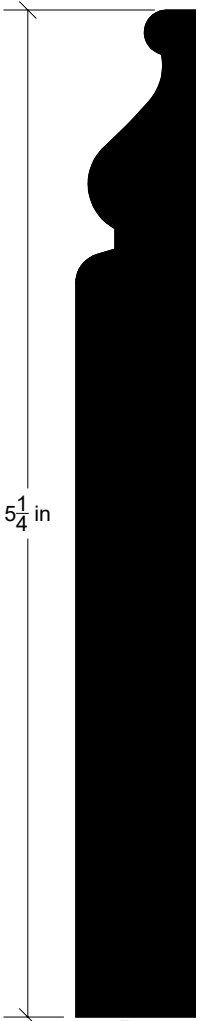

RBM BA-33

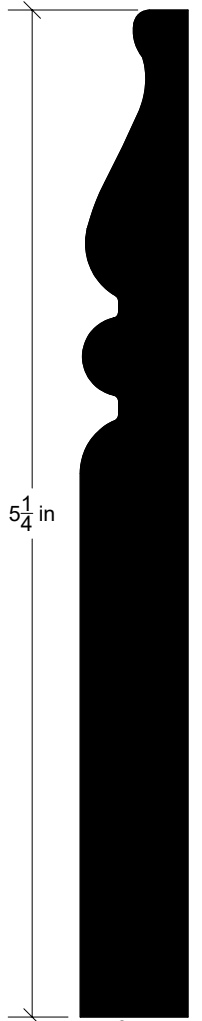

RBM BA-34

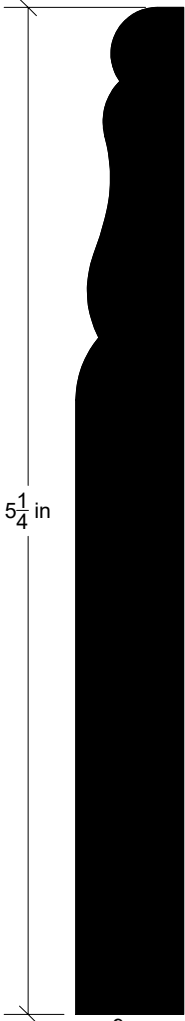

RBM BA-35

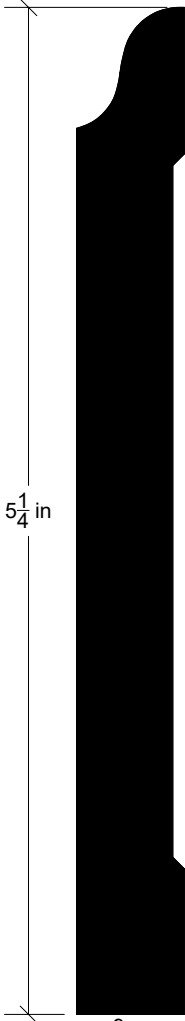

RBM BA-36

Baseboards

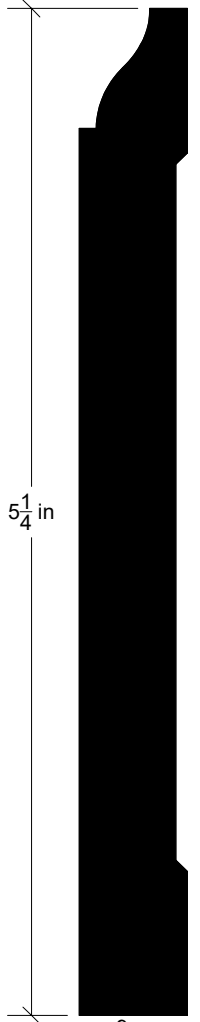

RBM BA-37

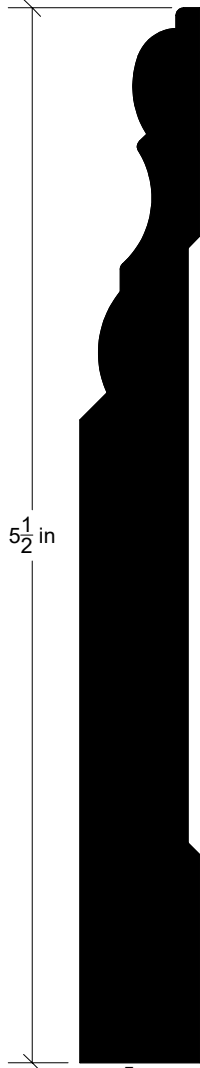

RBM BA-40

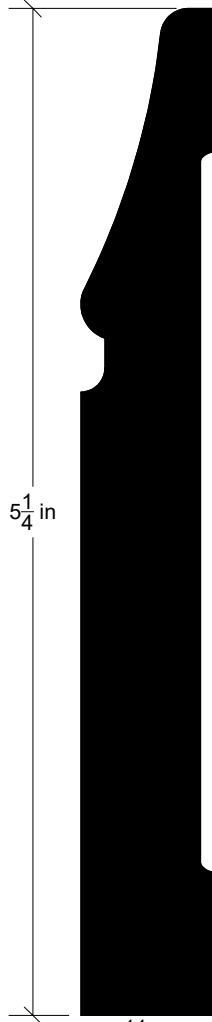

RBM BA-38

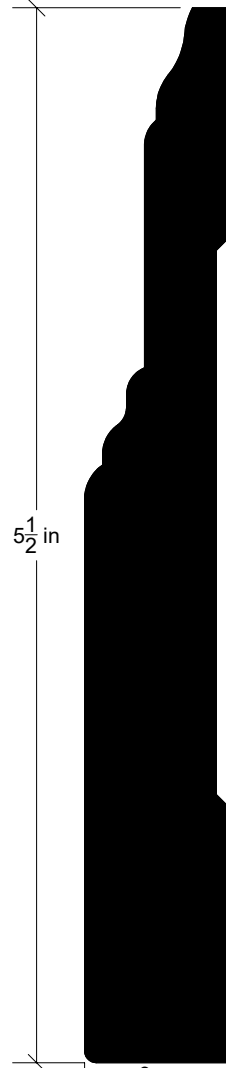

RBM BA-41

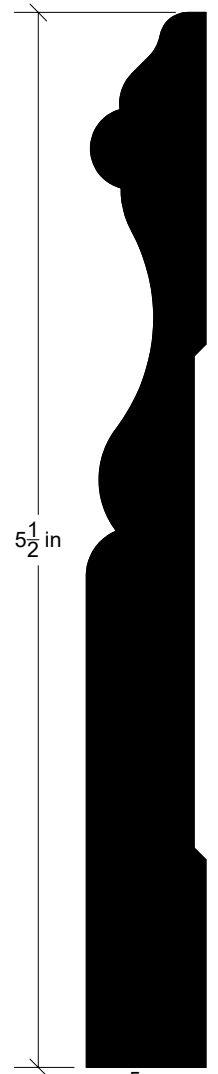

RBM BA-39

Baseboards

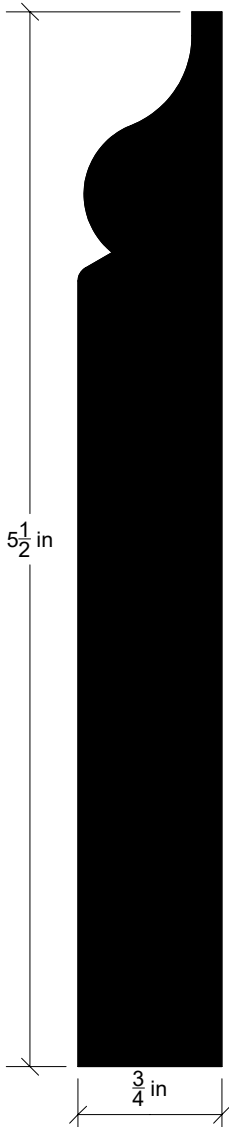

RBM BA-42

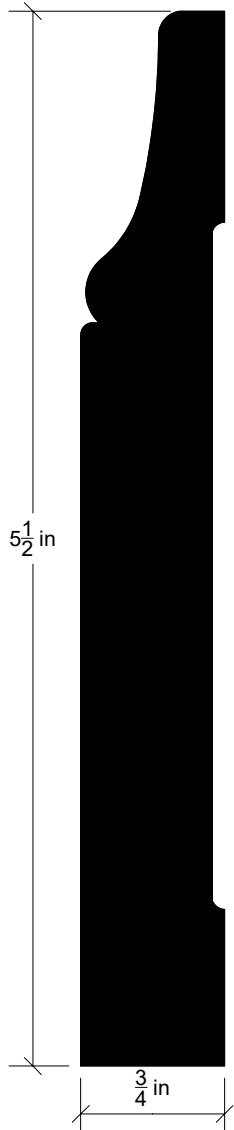

RBM BA-45

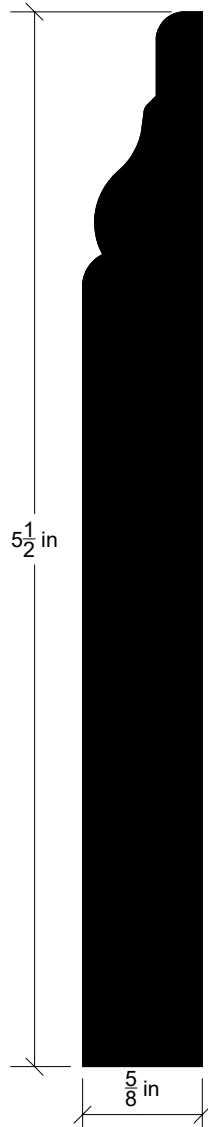

RBM BA-43

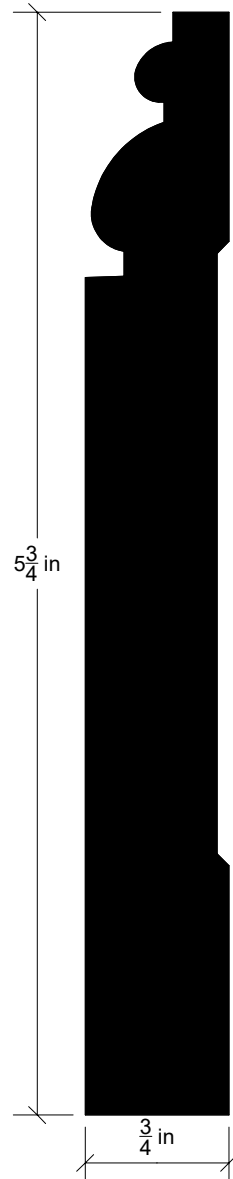

RBM BA-46

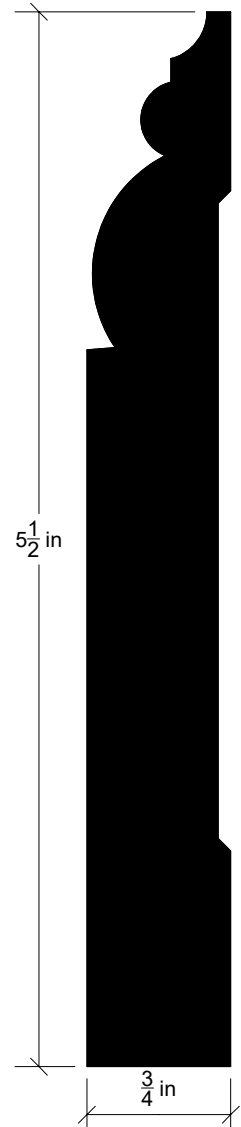

RBM BA-44

Baseboards

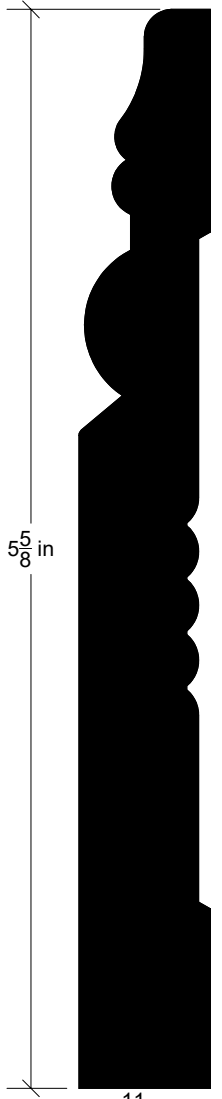

RBM BA-47

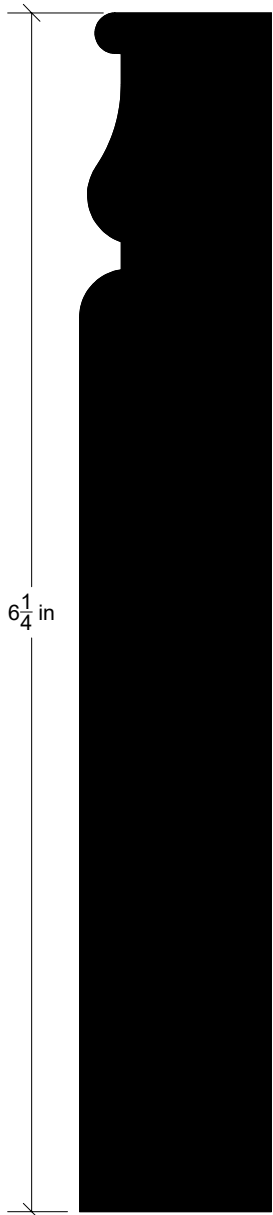

RBM BA-50

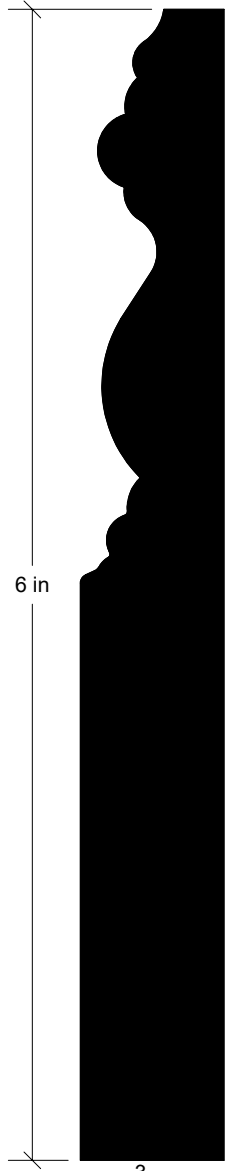

RBM BA-48

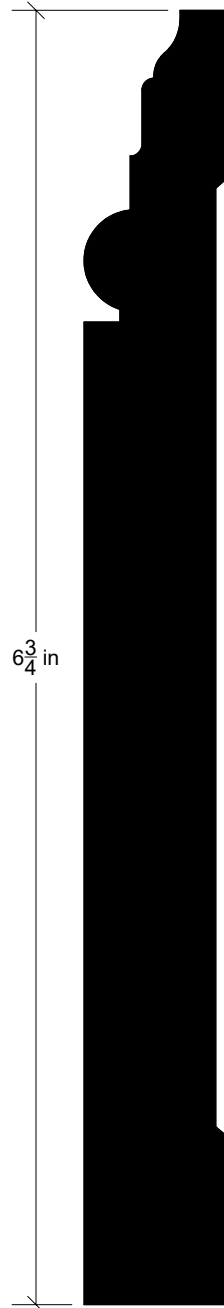

RBM BA-51

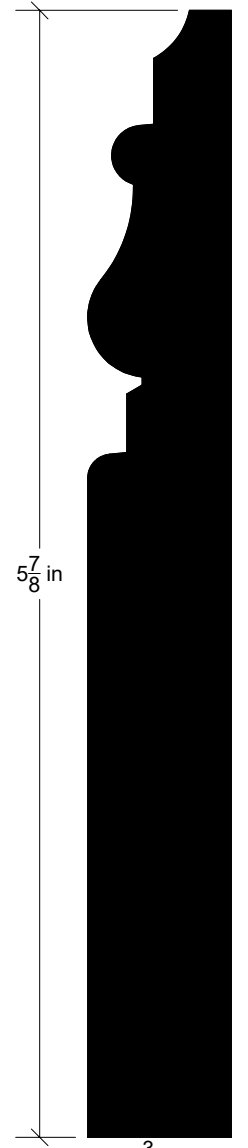

RBM BA-49

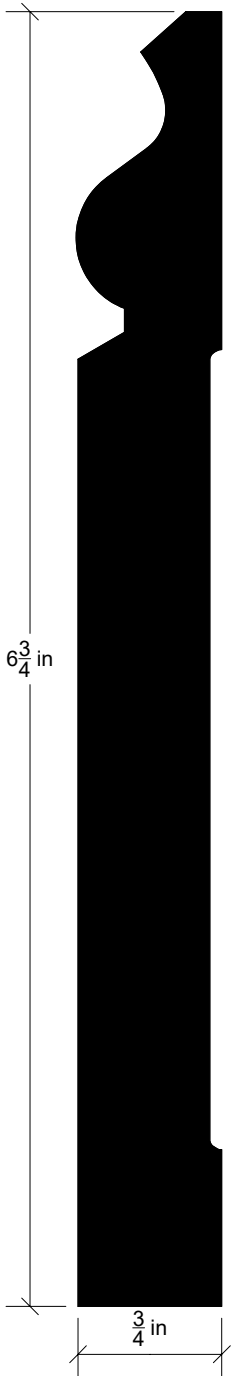

RBM BA-52

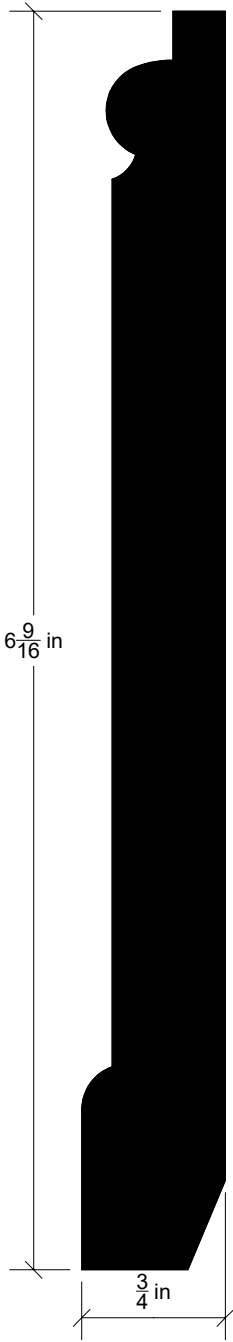

RBM BA-55

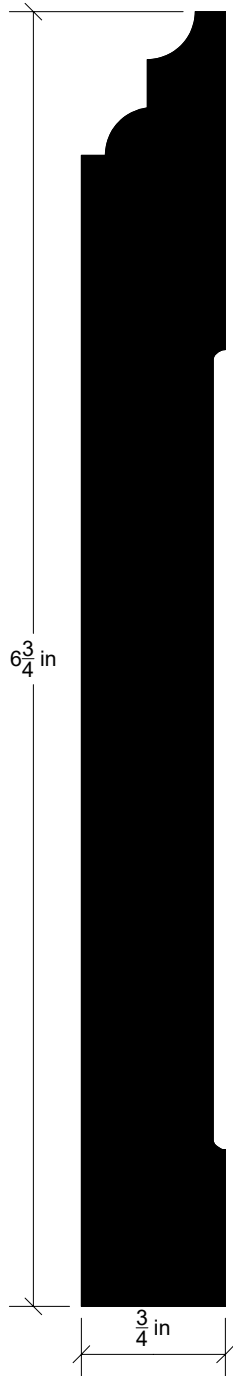

RBM BA-53

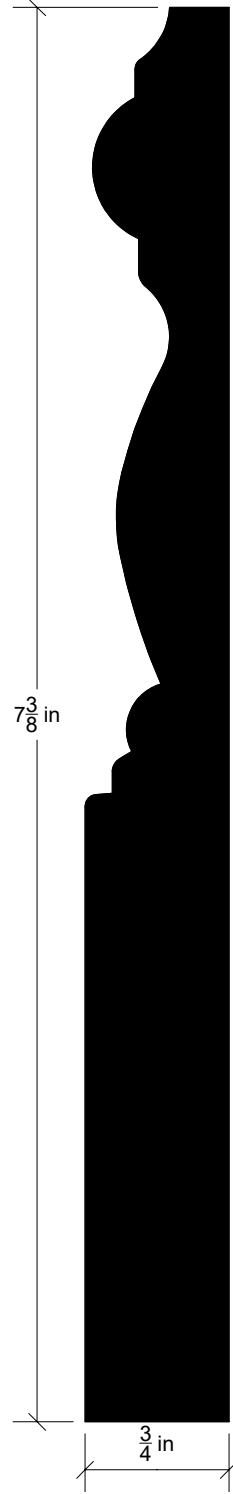

RBM BA-56

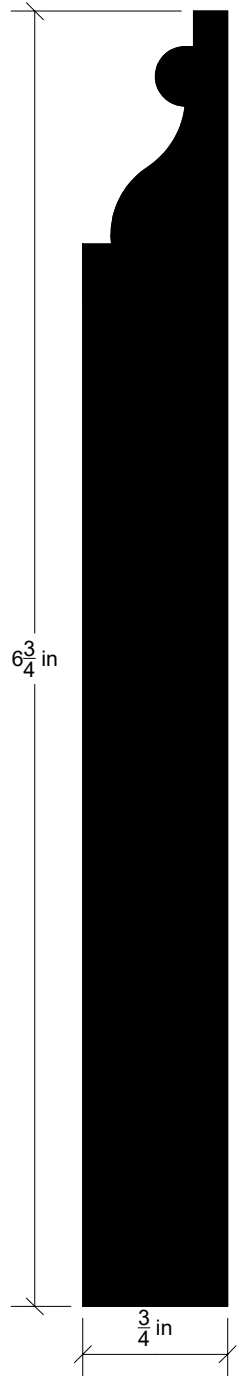

RBM BA-54

Baseboards

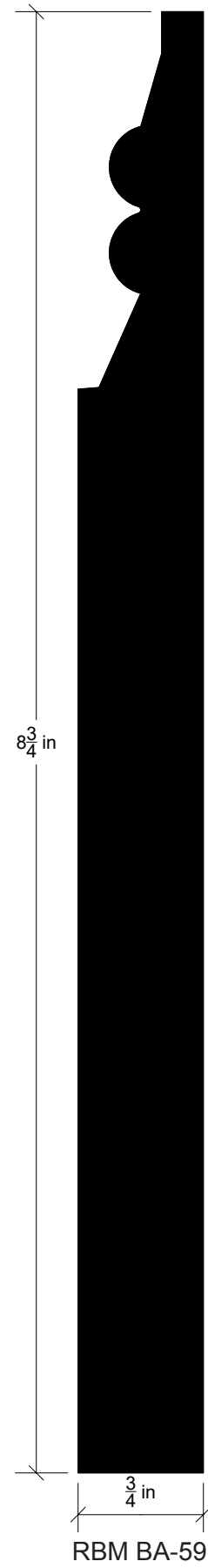
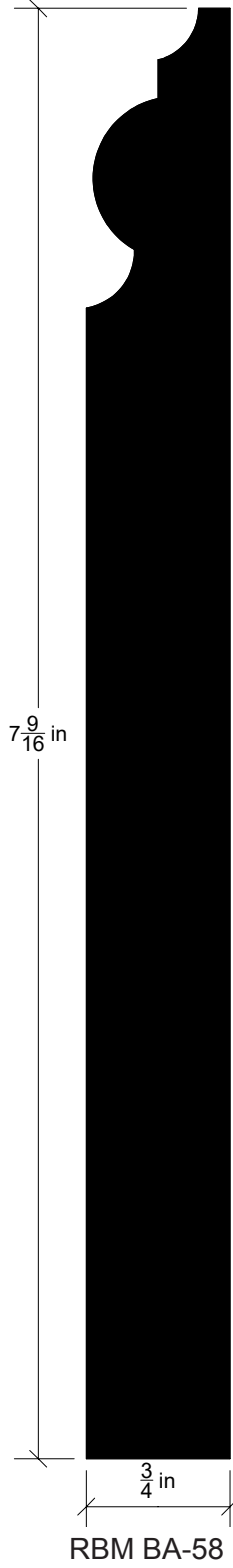
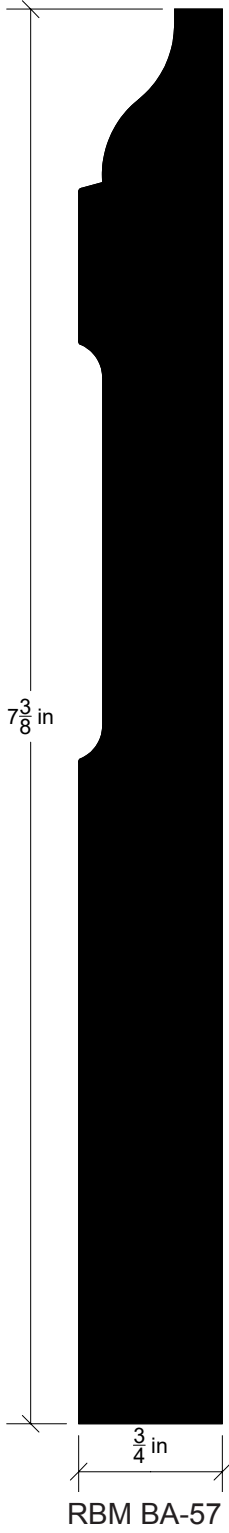

RBM Band-01

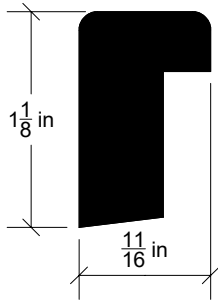

RBM Band-06

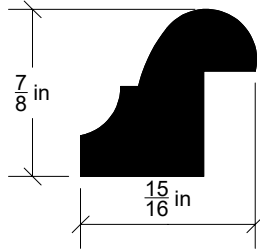

RBM Band-10

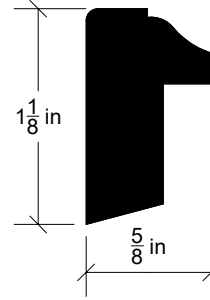

RBM Band-02

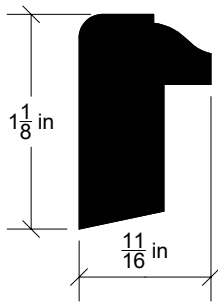

RBM Band-07

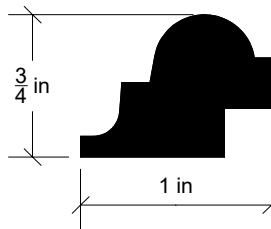

RBM Band-11

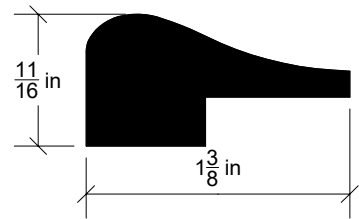

RBM Band-03

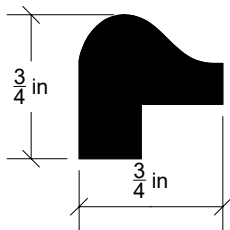

RBM Band-08

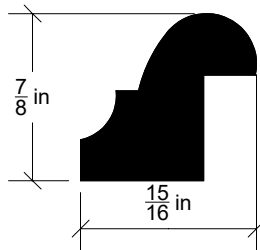

RBM Band-12

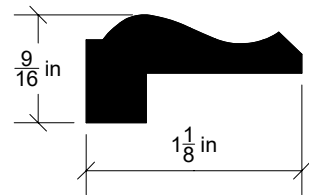

RBM Band-04

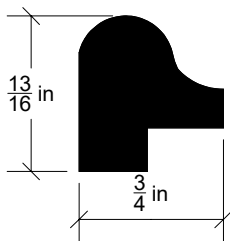

RBM Band-09

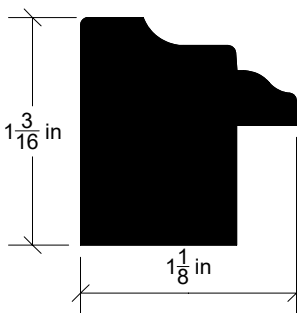

RBM Band-13

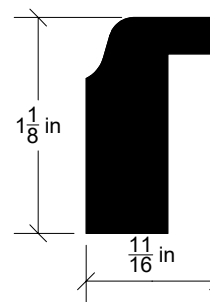

RBM Band-05

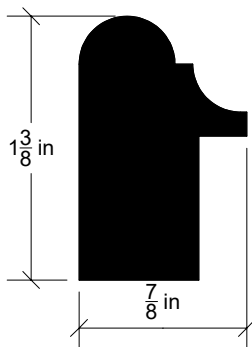

RBM Band-14

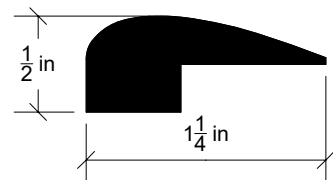

Bands

RBM Band-15

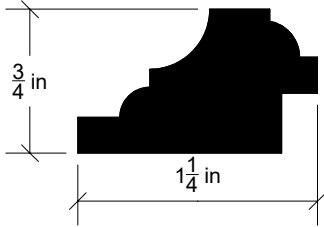

RBM Band-19

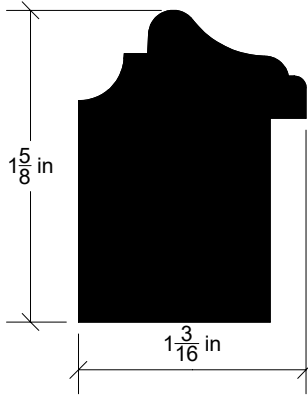

RBM Band-23

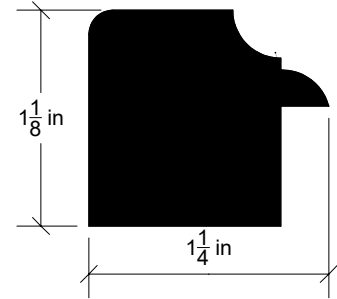

RBM Band-16

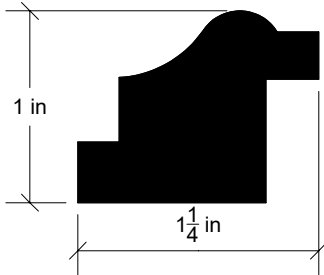

RBM Band-20

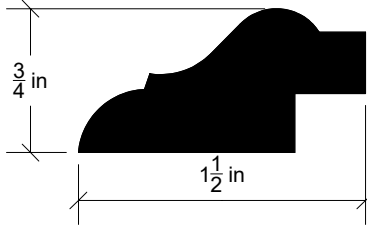

RBM Band-24

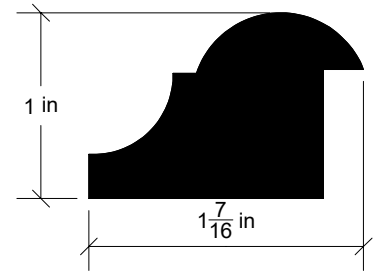

RBM Band-17

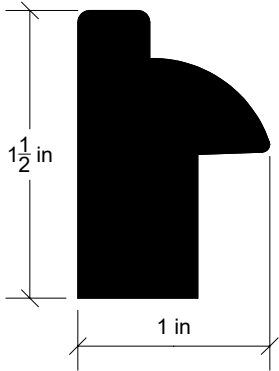

RBM Band-21

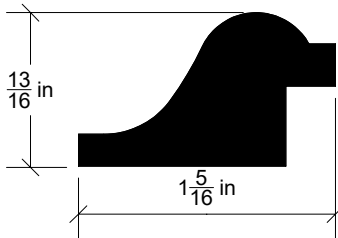

RBM Band-25

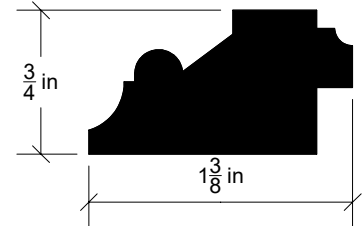

RBM Band-18

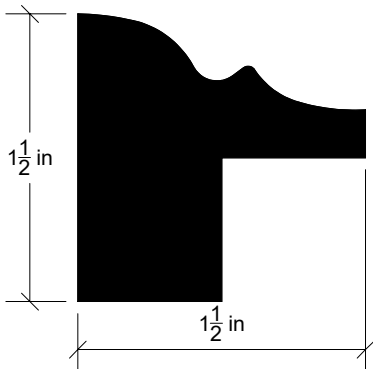

RBM Band-22

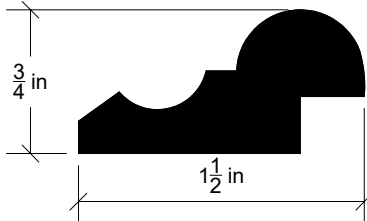

RBM Band-26

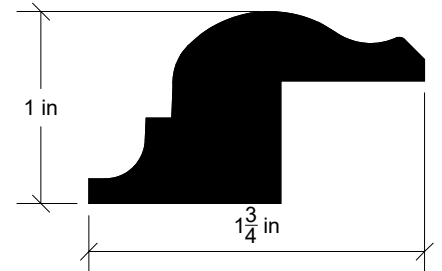

RBM Band-27

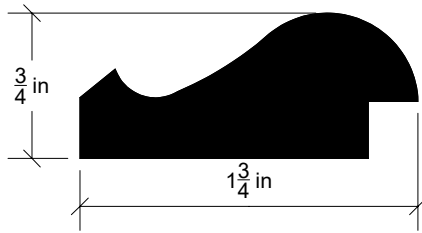

RBM Band-32

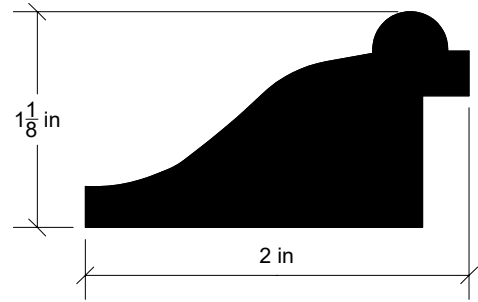

RBM Band-28

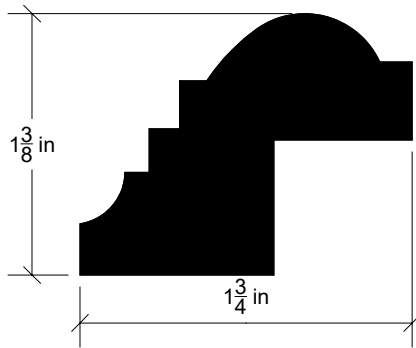

RBM Band-33

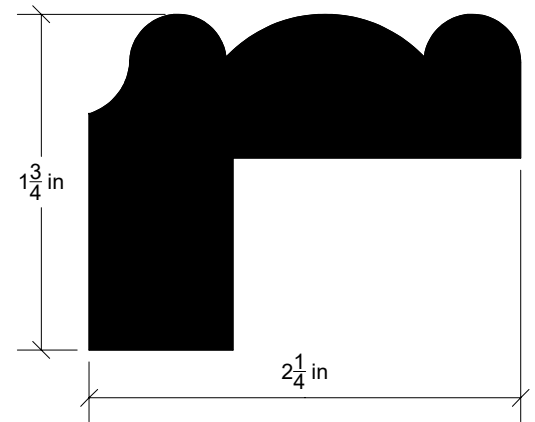

RBM Band-29

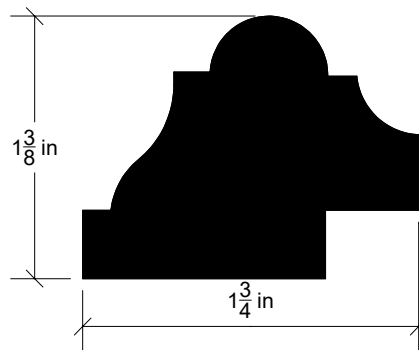

RBM Band-30

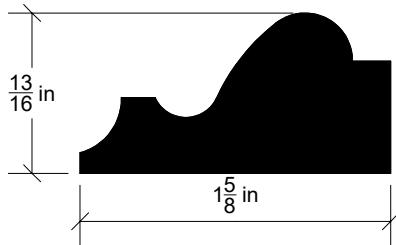

RBM Band-34

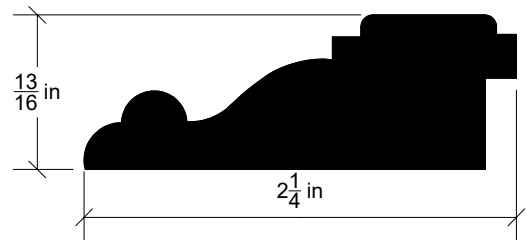

RBM Band-31

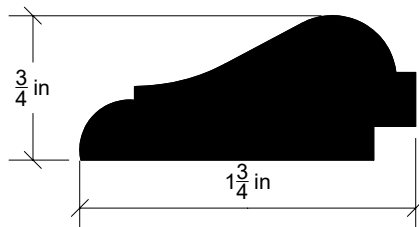

RBM Band-35

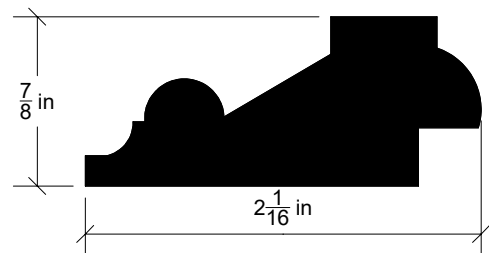

RBM Cap-01

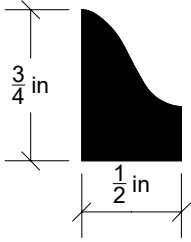

RBM Cap-06

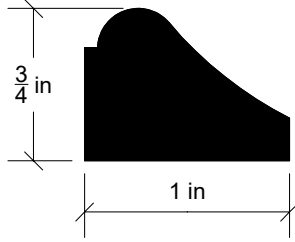

RBM Cap-11

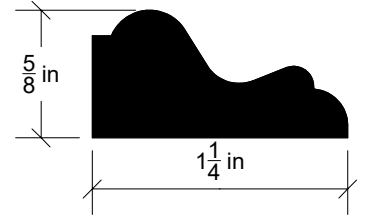

RBM Cap-02

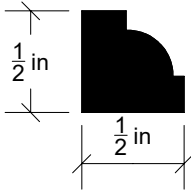

RBM Cap-07

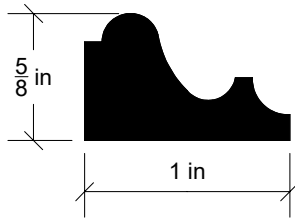

RBM Cap-12

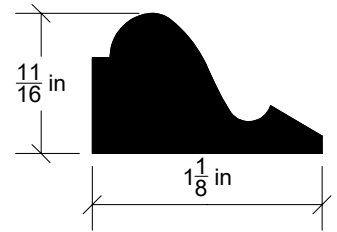

RBM Cap-03

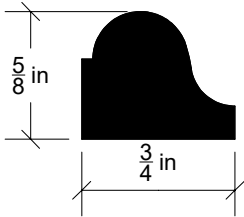

RBM Cap-08

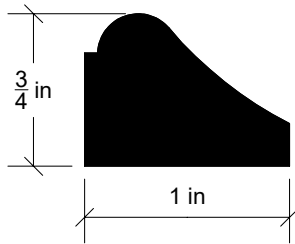

RBM Cap-13

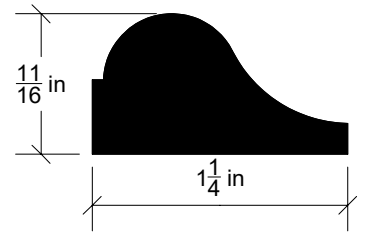

RBM Cap-04

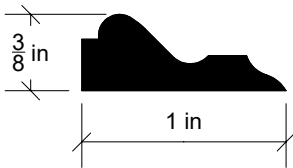

RBM Cap-09

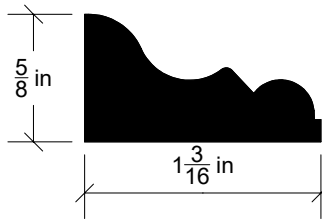

RBM Cap-14

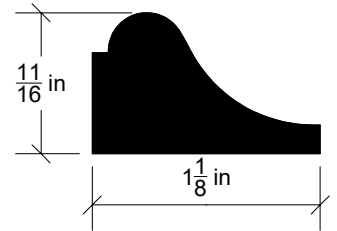

RBM Cap-05

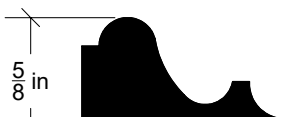

RBM Cap-10



RBM Cap-15



RBM Cap-16

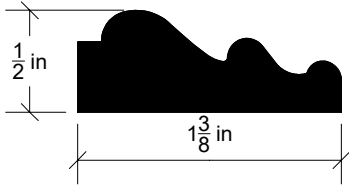

RBM Cap-21

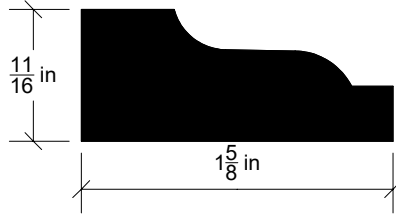

RBM Cap-26

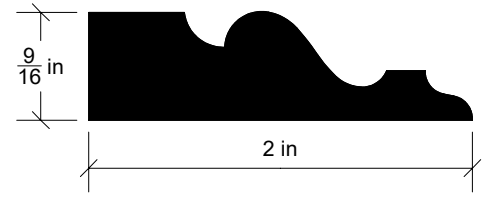

RBM Cap-17

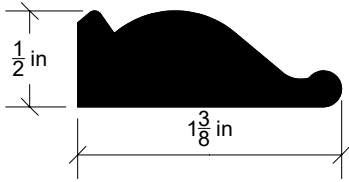

RBM Cap-22

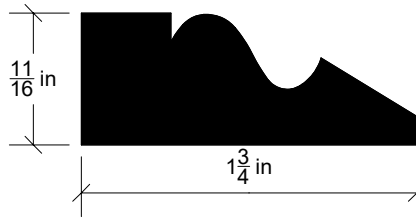

RBM Cap-27

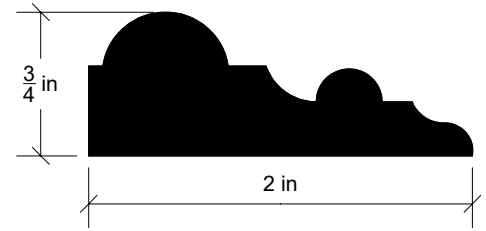

RBM Cap-18

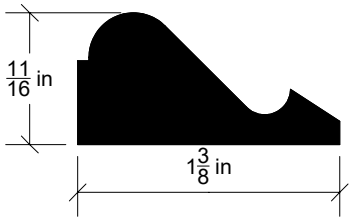

RBM Cap-23

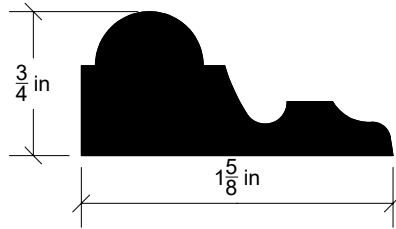

RBM Cap-28

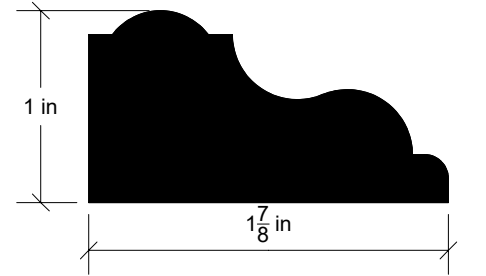

RBM Cap-19

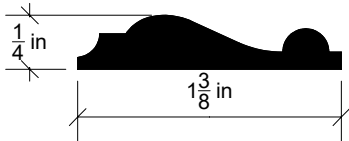

RBM Cap-24

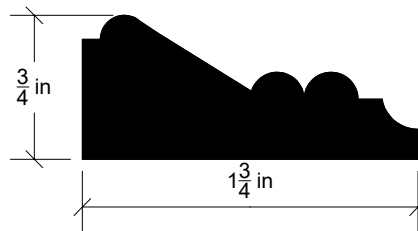

RBM Cap-29

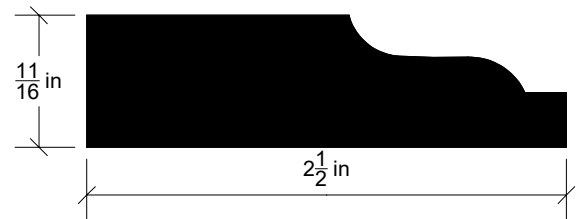

RBM Cap-20

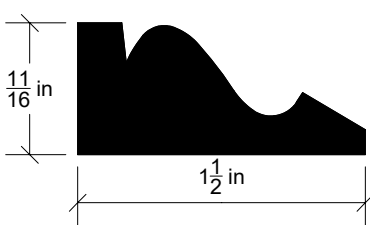

RBM Cap-25

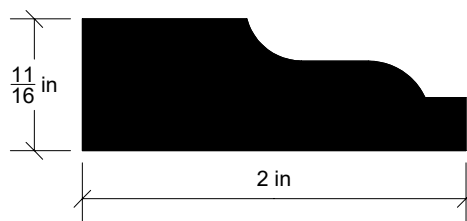

RBM Cap-30

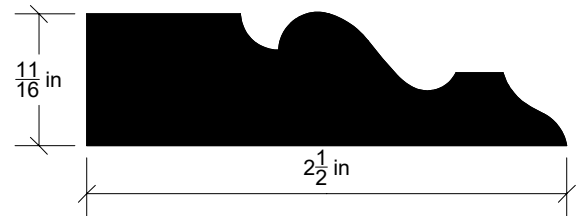

Casing

RBM Cas225-001

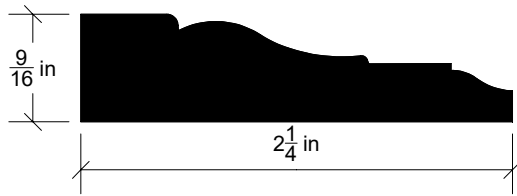

RBM Cas225-002

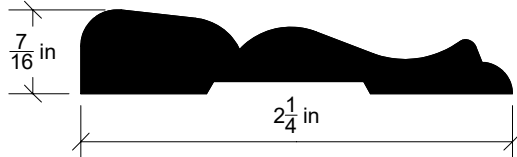

RBM Cas225-003 **MOST POPULAR**

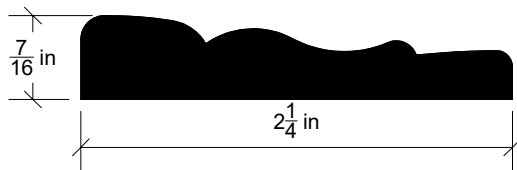

RBM Cas225-004

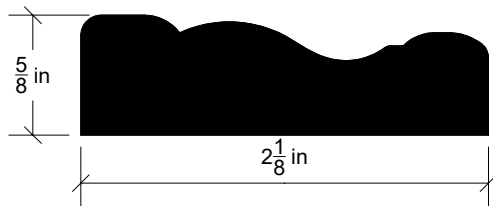

RBM Cas225-005

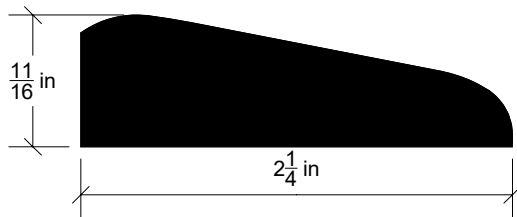

RBM Cas225-006

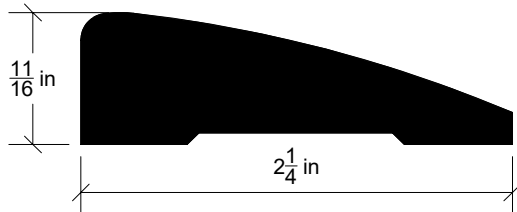

RBM Cas225-007 **MOST POPULAR**

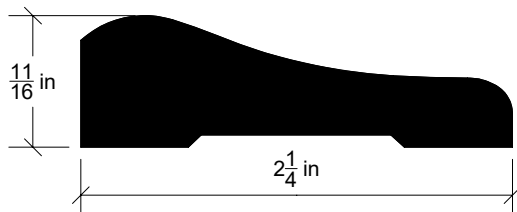

RBM Cas225-008

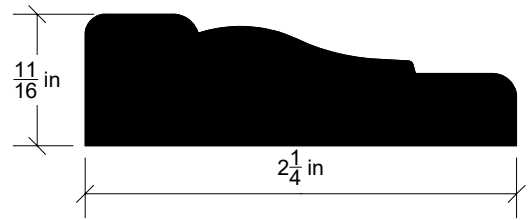

RBM Cas225-009

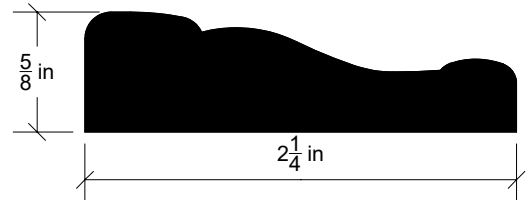

RBM Cas225-010

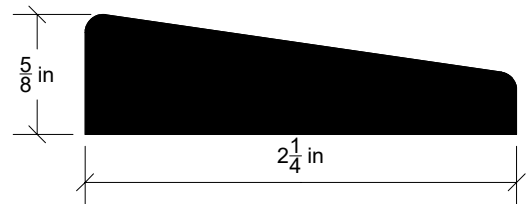

RBM Cas225-011

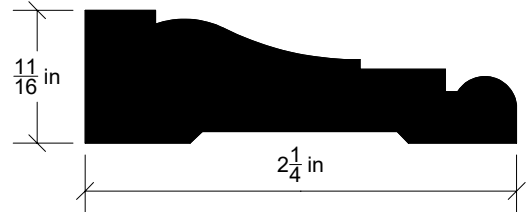

RBM Cas225-012

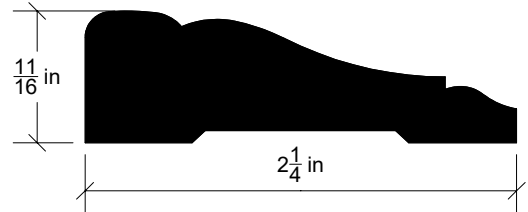

RBM Cas225-013

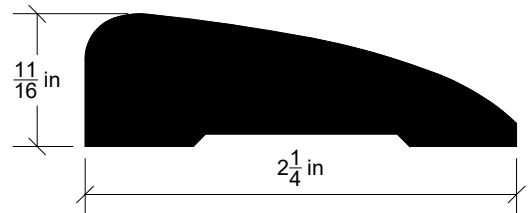

RBM Cas225-014

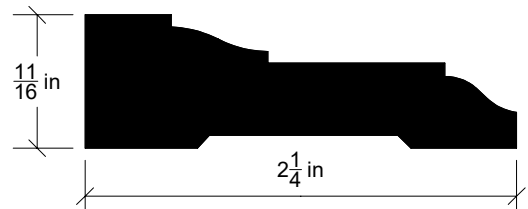

RBM Cas225-015

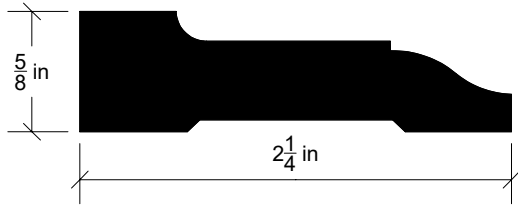

RBM Cas225-016

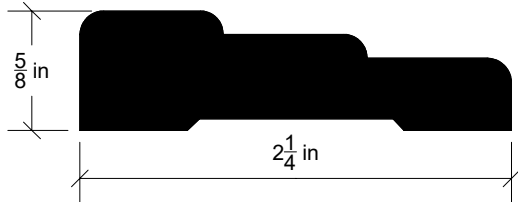

RBM Cas225-017

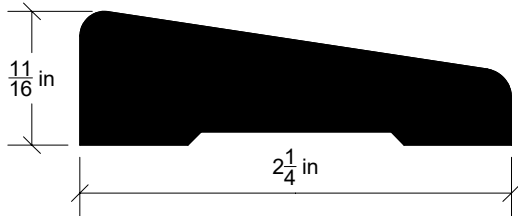

RBM Cas225-018

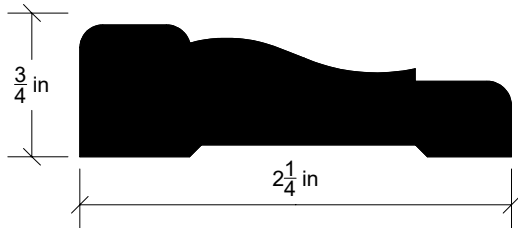

RBM Cas225-019

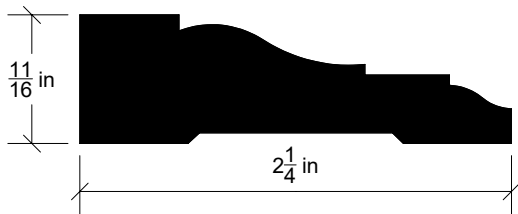

RBM Cas225-020

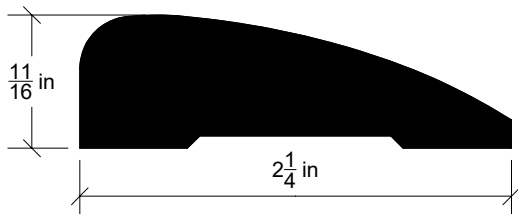

RBM Cas225-021

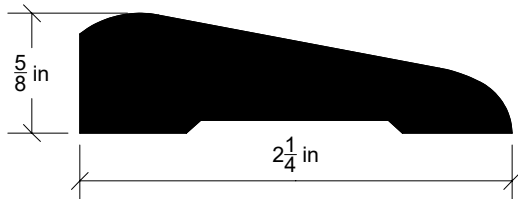

RBM Cas250-001

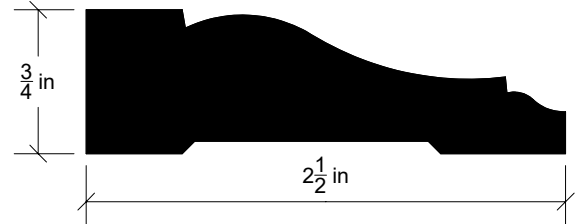

RBM Cas250-002

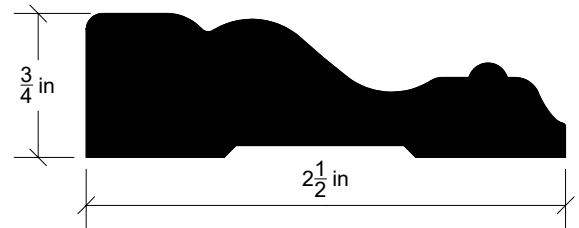

RBM Cas250-003

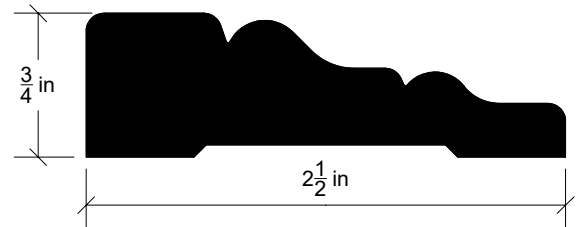

RBM Cas250-004

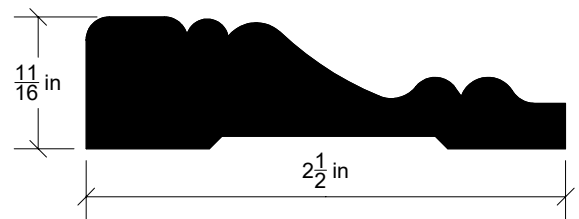

RBM Cas250-005

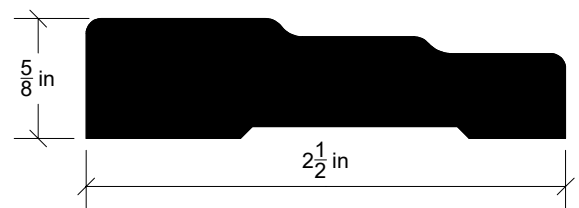

RBM Cas250-006

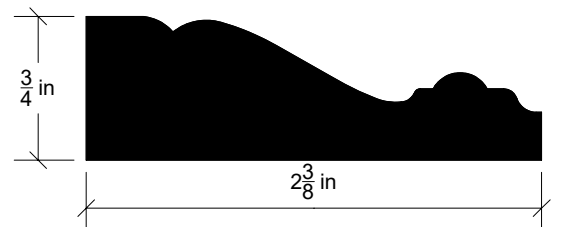

RBM Cas250-007

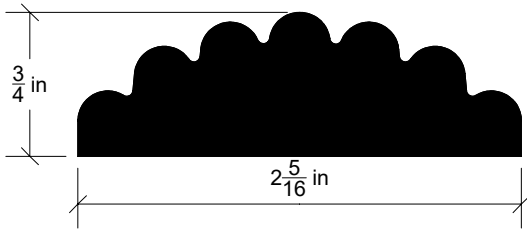

RBM Cas250-013

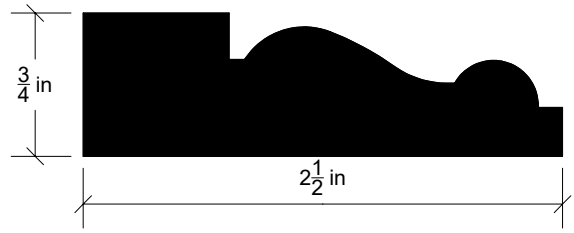

RBM Cas250-008

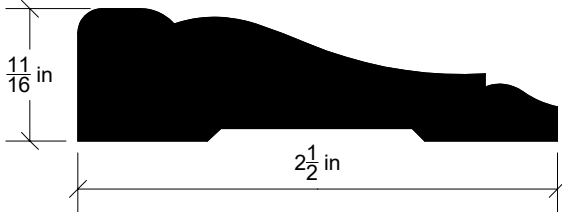

RBM Cas250-014

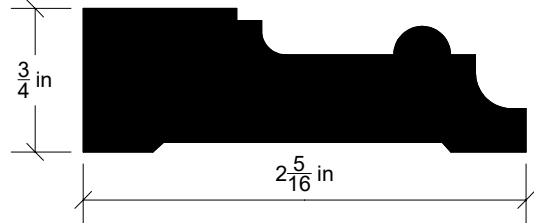

RBM Cas250-009

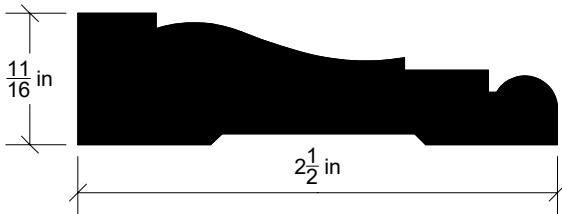

RBM Cas250-015

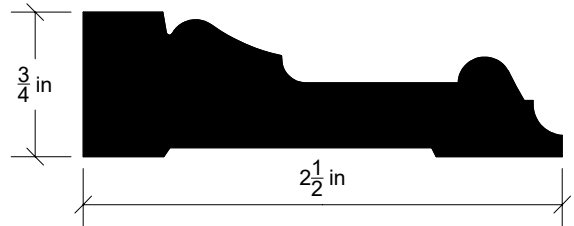

RBM Cas250-010

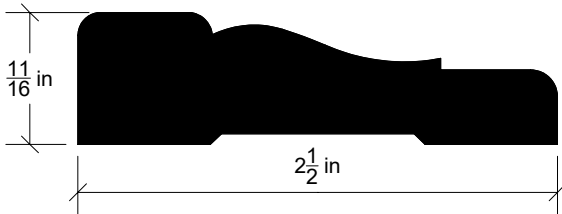

RBM Cas250-016

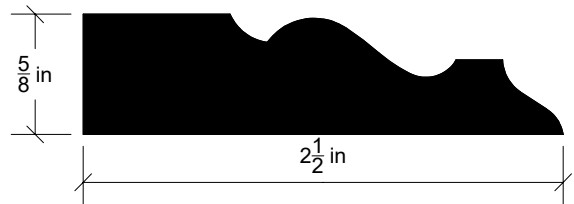

RBM Cas250-011

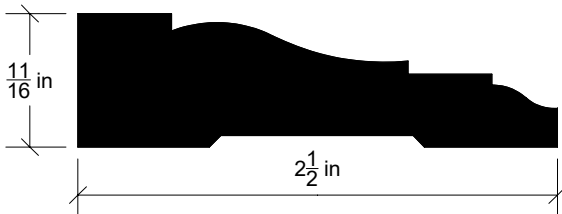

RBM Cas275-001

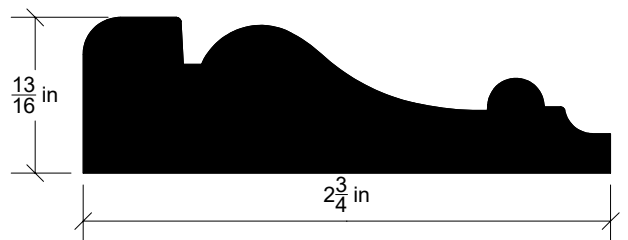

RBM Cas250-012

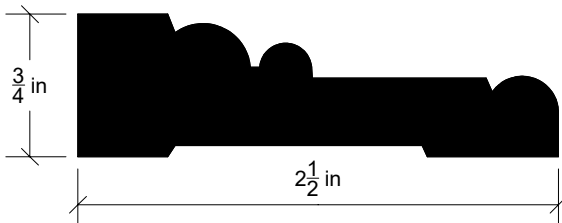

RBM Cas275-002

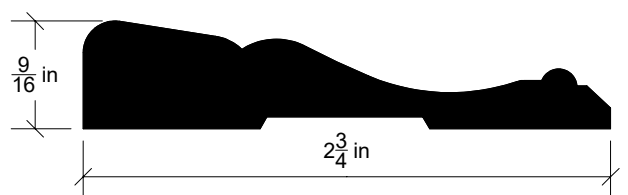

RBM Cas275-003

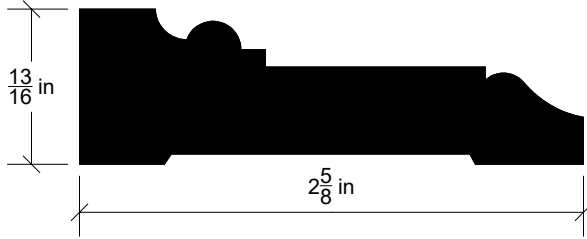

RBM Cas275-004

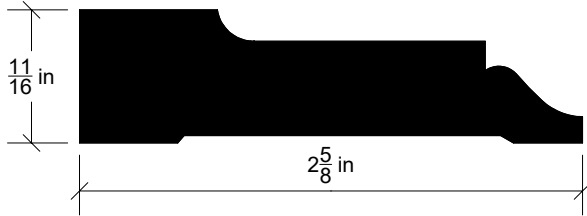

RBM Cas275-005

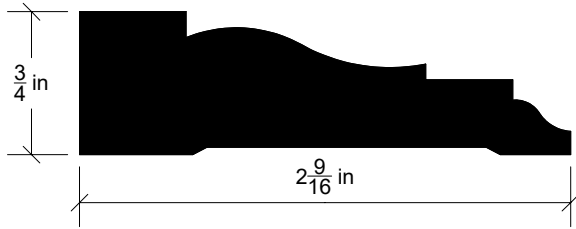

RBM Cas275-006

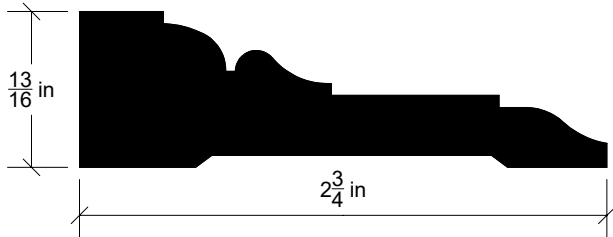

RBM Cas275-007

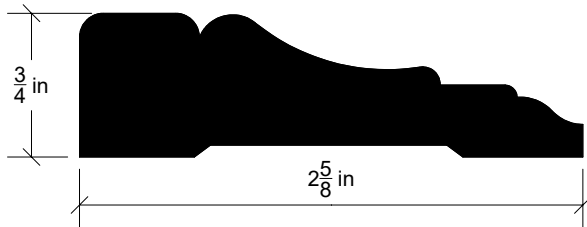

RBM Cas275-008

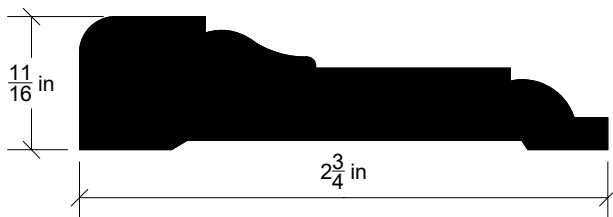

RBM Cas275-009

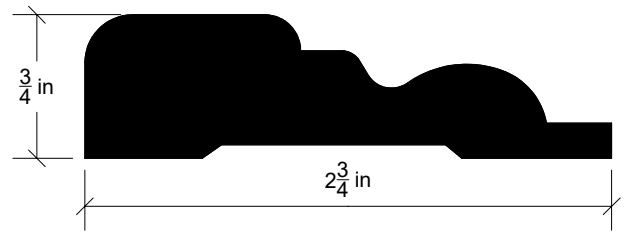

RBM Cas275-010

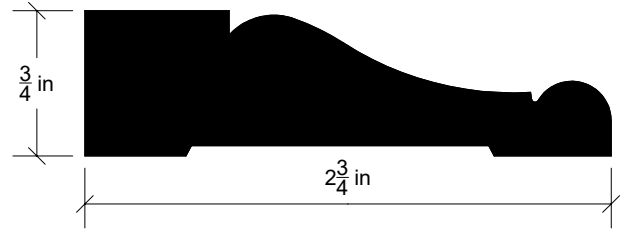

RBM Cas275-011

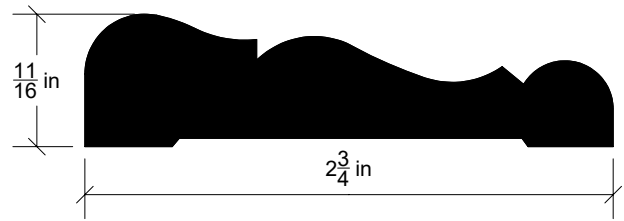

RBM Cas300-001

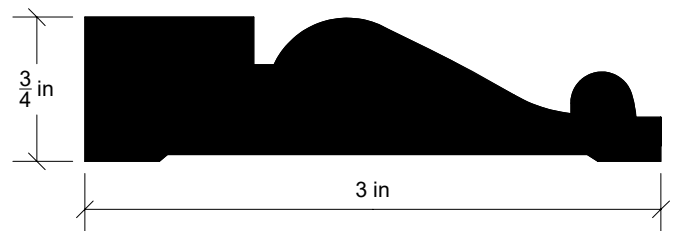

RBM Cas300-002

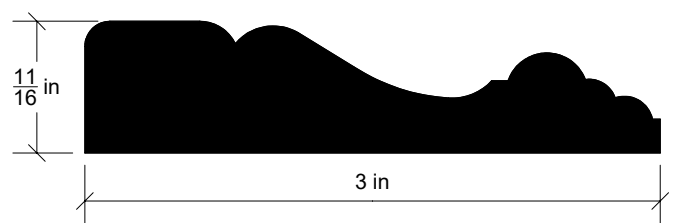

RBM Cas300-003

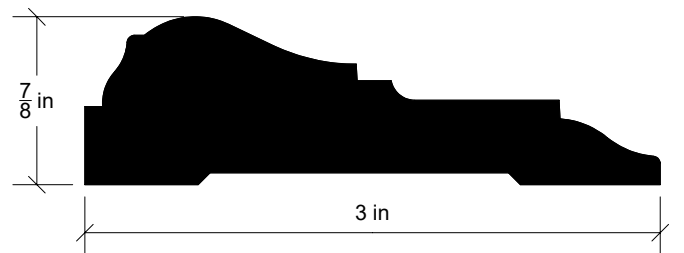

Casing

RBM Cas300-004

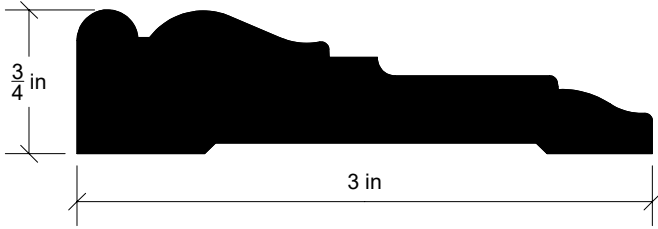

RBM Cas300-010



RBM Cas300-005

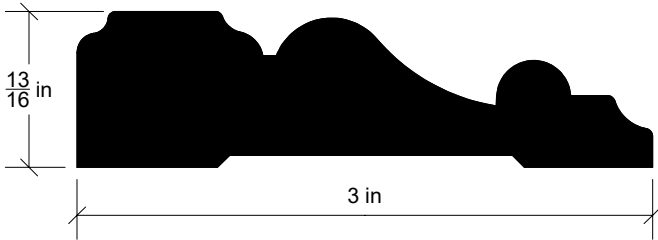

RBM Cas300-011

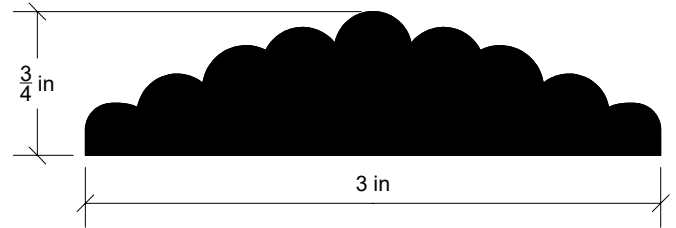

RBM Cas300-006

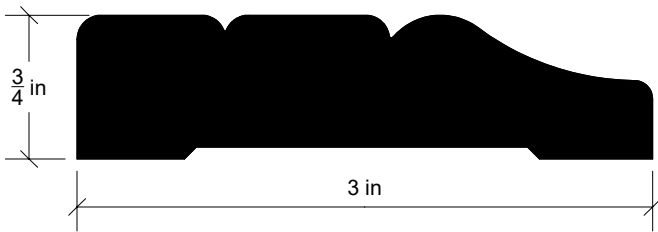

RBM Cas300-012

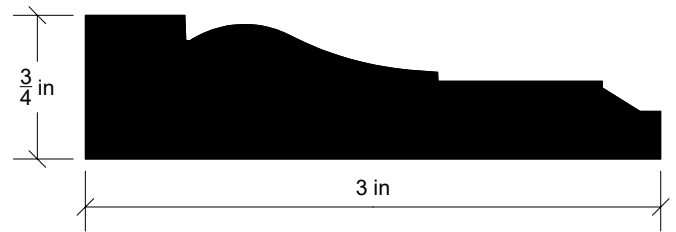

RBM Cas300-007

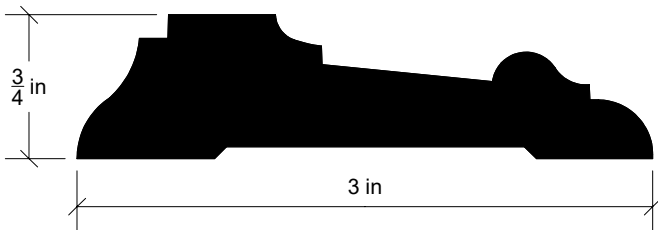

RBM Cas300-013



RBM Cas300-008

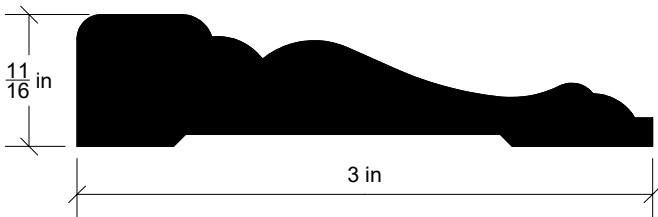

RBM Cas325-001

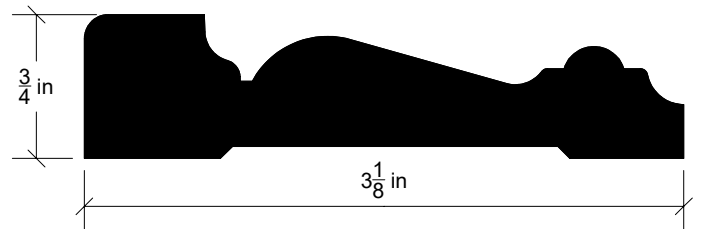

RBM Cas300-009

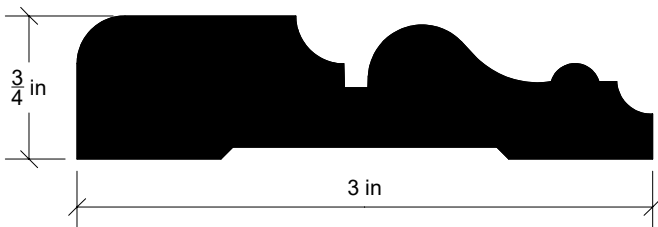

RBM Cas325-002

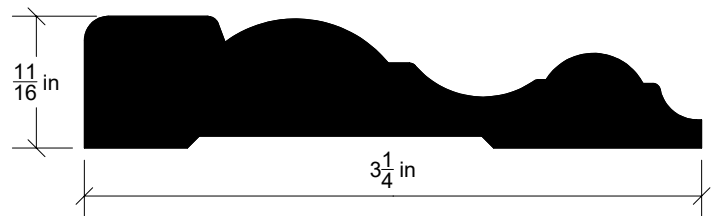

RBM Cas325-003 **MOST POPULAR**

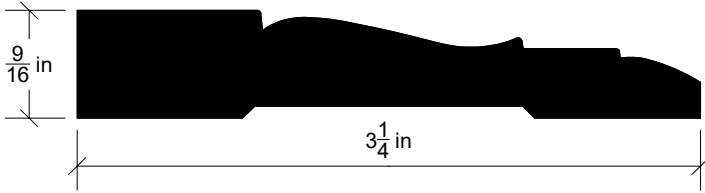

RBM Cas350-002

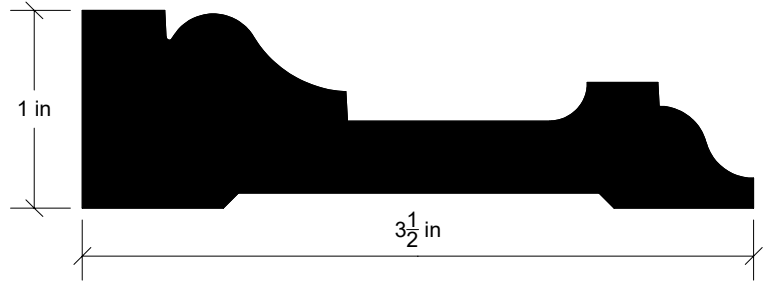

RBM Cas325-004

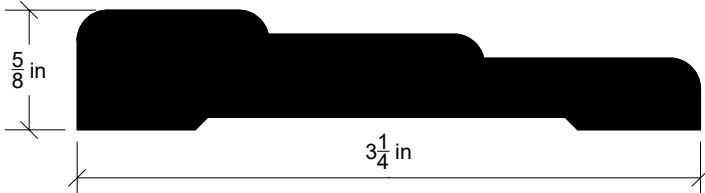

RBM Cas350-003

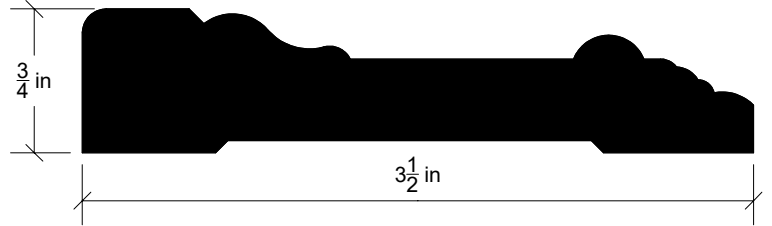

RBM Cas325-005

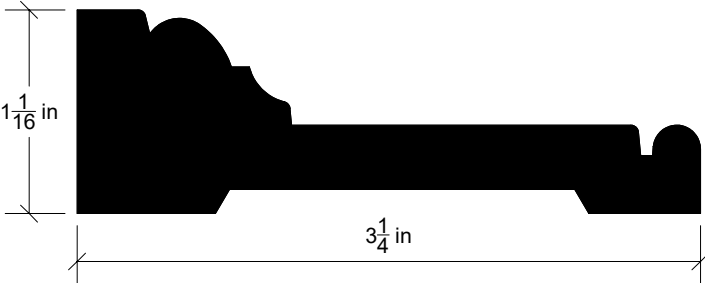

RBM Cas350-004

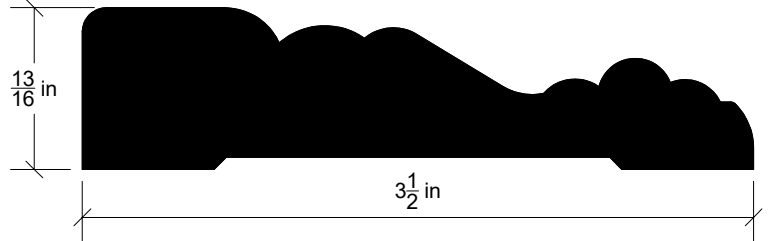

RBM Cas325-006

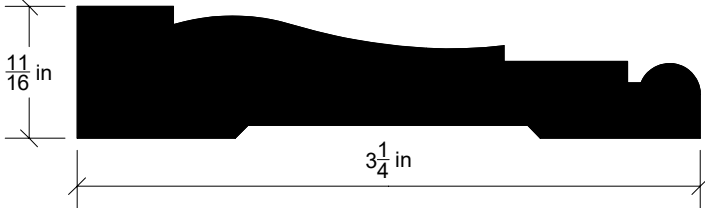

RBM Cas350-005

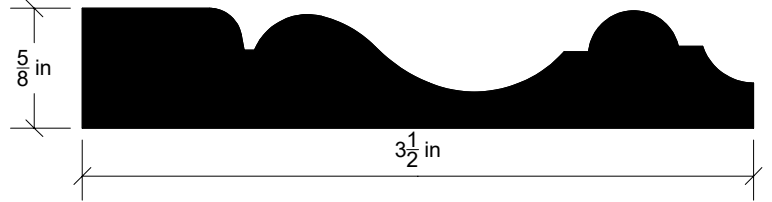

RBM Cas325-007

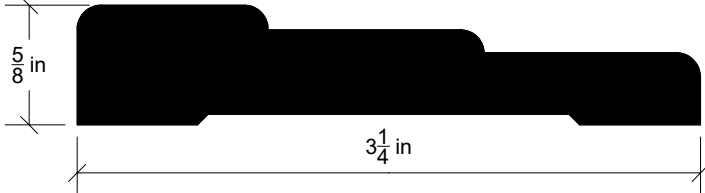

RBM Cas350-006

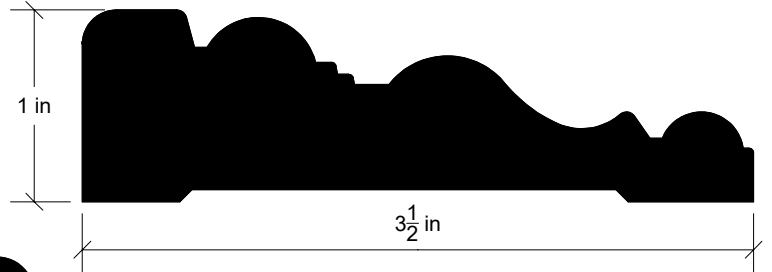

RBM Cas350-001

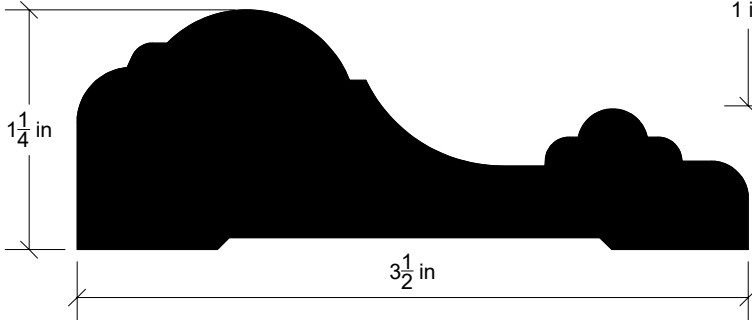

Casing

RBM Cas350-007

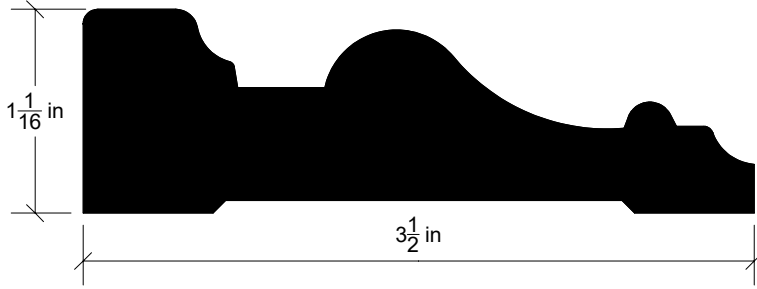

RBM Cas350-010

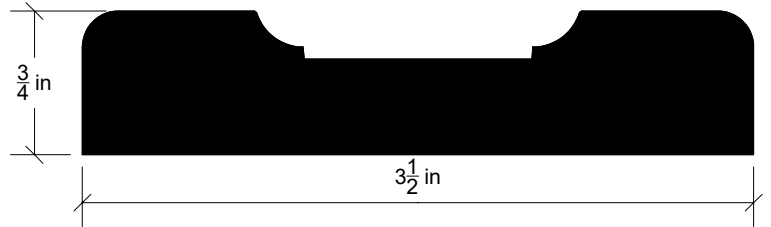

RBM Cas350-008

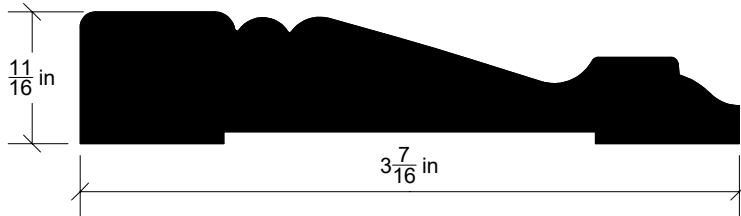

RBM Cas350-011

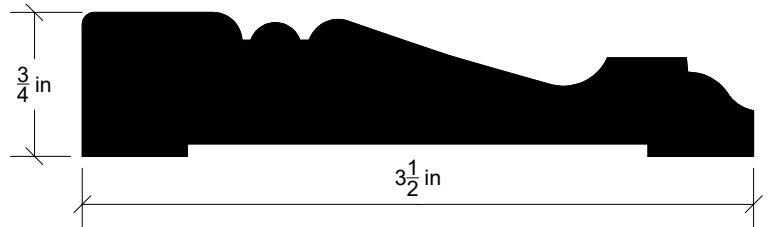

RBM Cas350-009

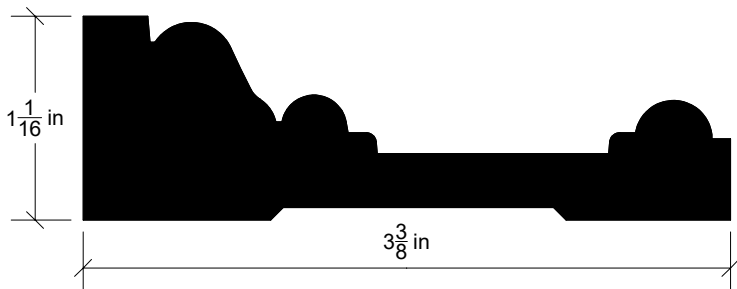

RBM Cas350-012

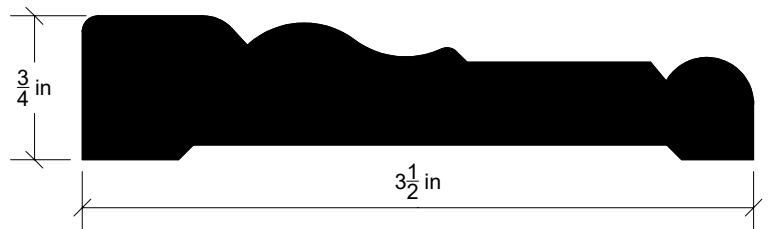

RBM Cas350-013

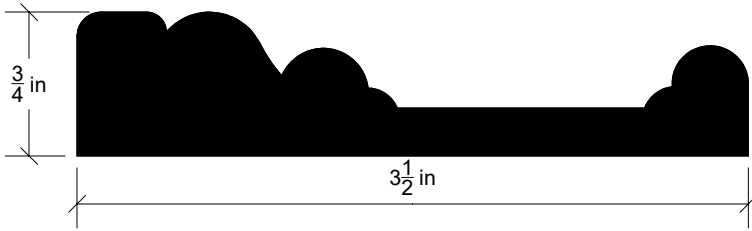

RBM Cas350-016

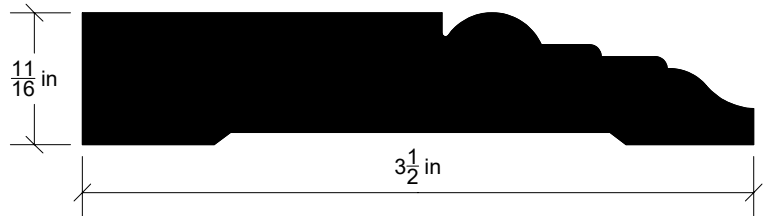

RBM Cas350-014 **MOST POPULAR**

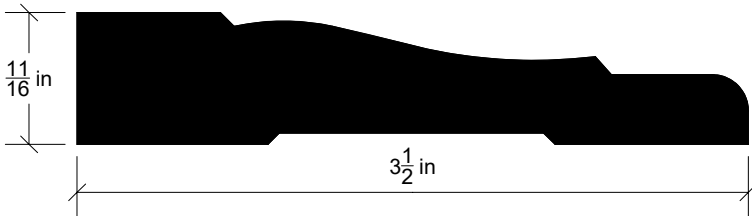

RBM Cas350-017

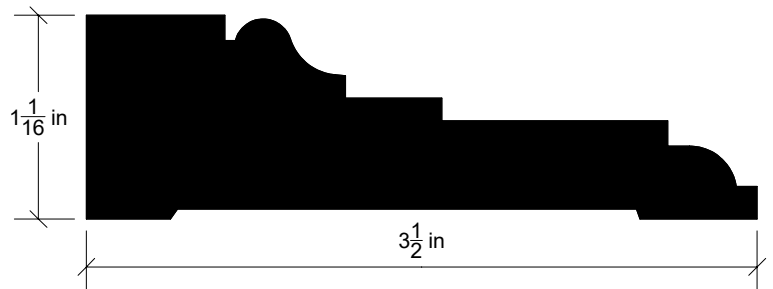

RBM Cas350-015

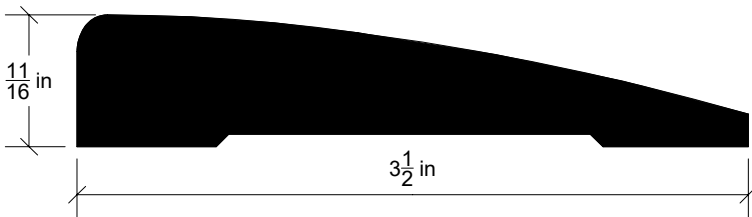

RBM Cas350-018

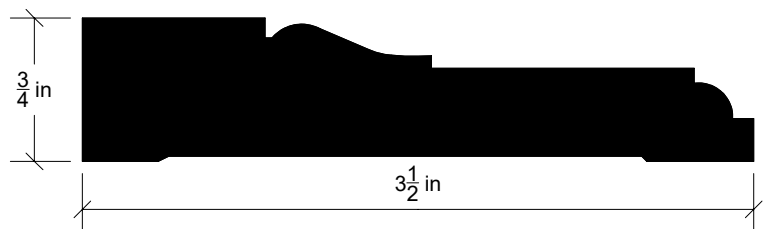

Casing

RBM Cas375-001

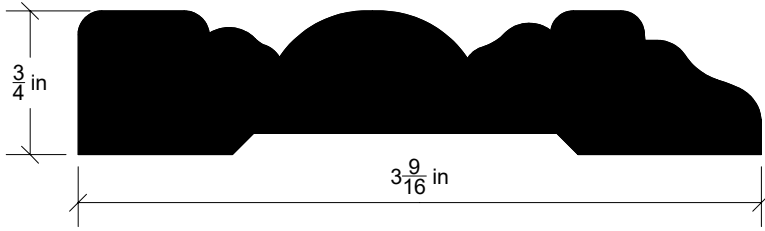

RBM Cas375-004

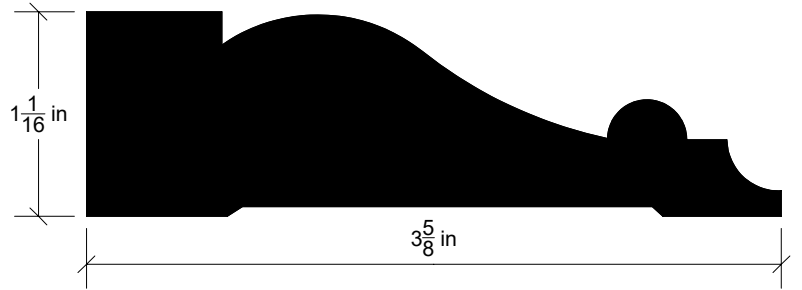

RBM Cas375-002

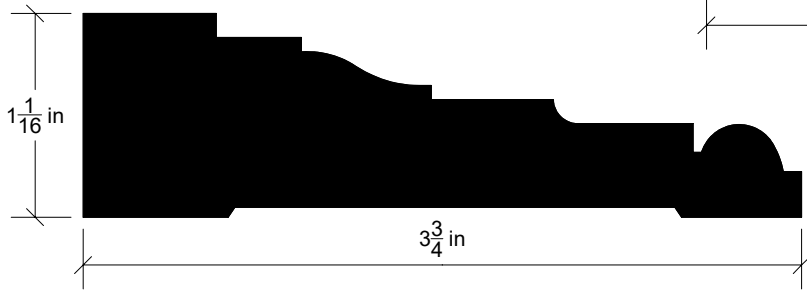

RBM Cas400-001

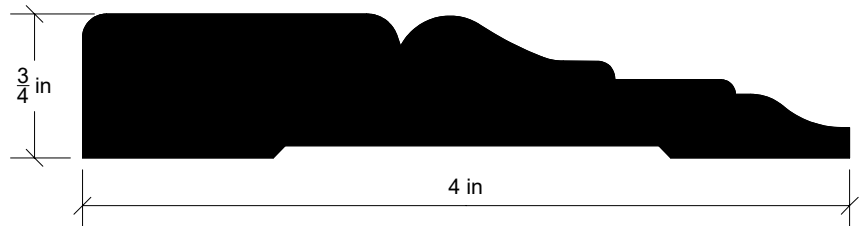

RBM Cas375-003

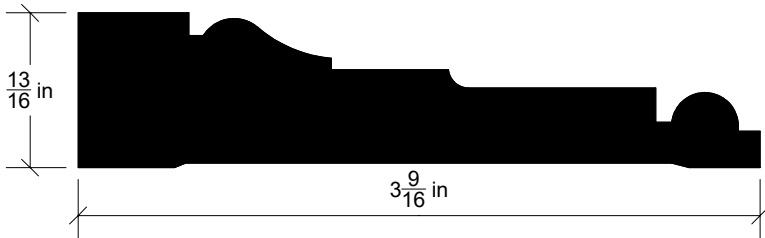

RBM Cas400-002

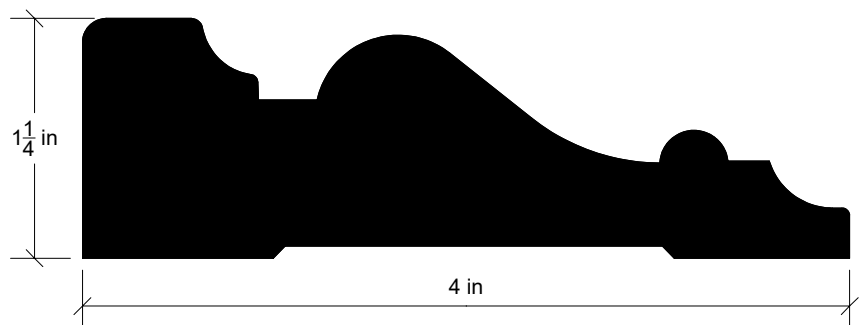

RBM Cas400-003 **MOST POPULAR**

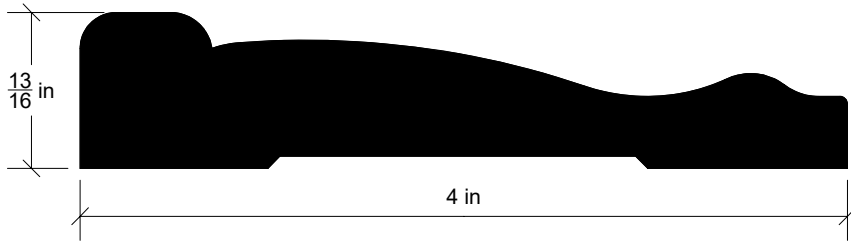

RBM Cas400-006

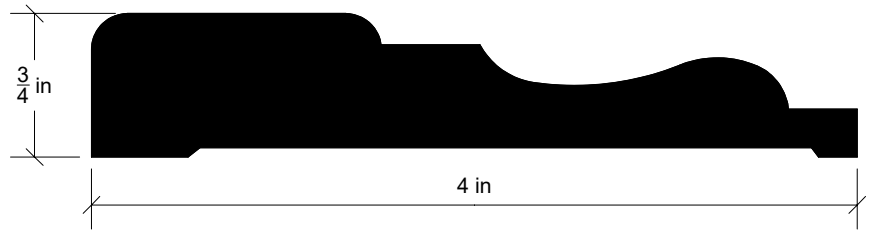

RBM Cas400-004

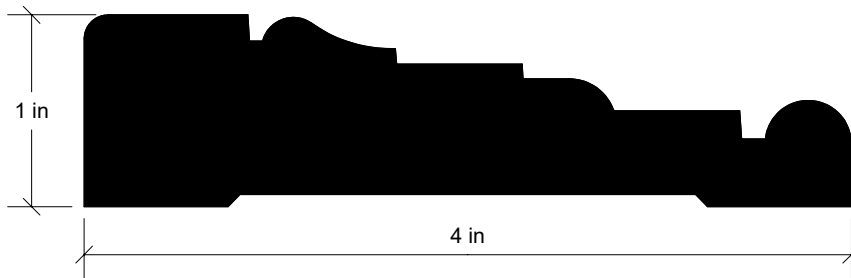

RBM Cas400-007

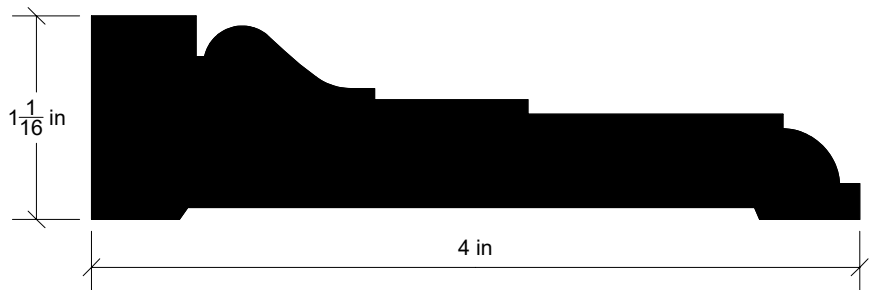

RBM Cas400-005

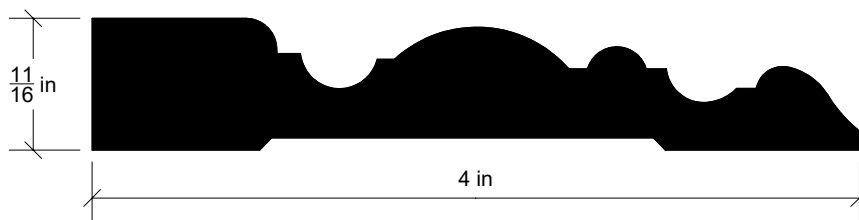

RBM Cas425-001

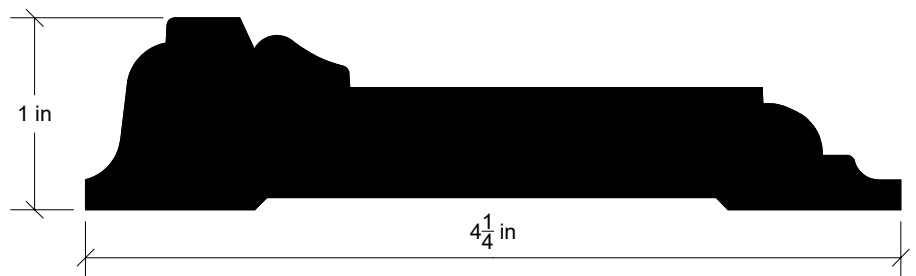

RBM Cas425-002

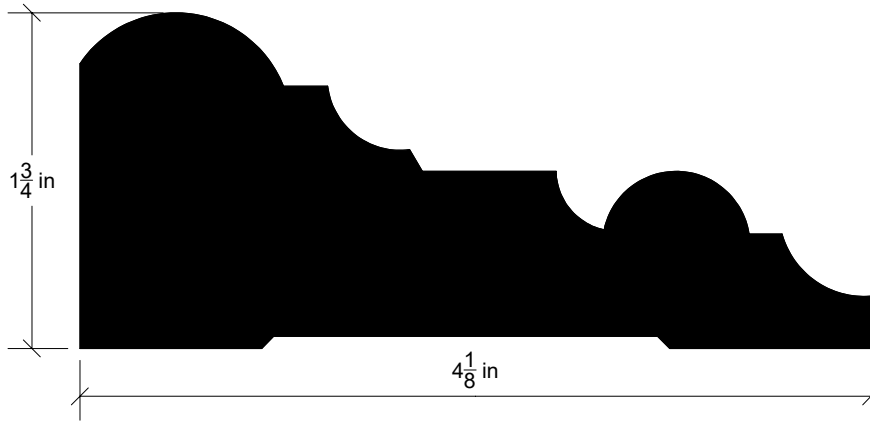

RBM Cas425-003

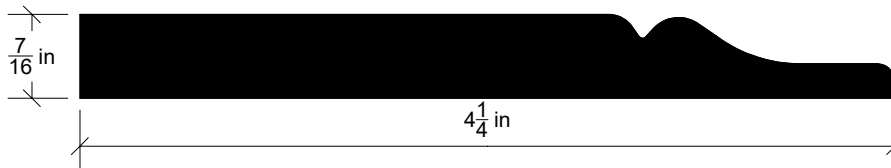

RBM Cas425-004

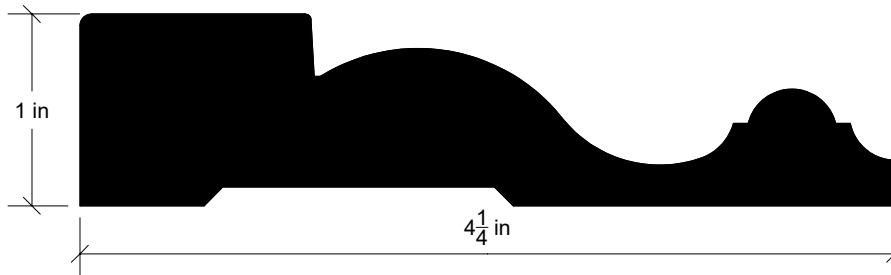

RBM Cas425-005

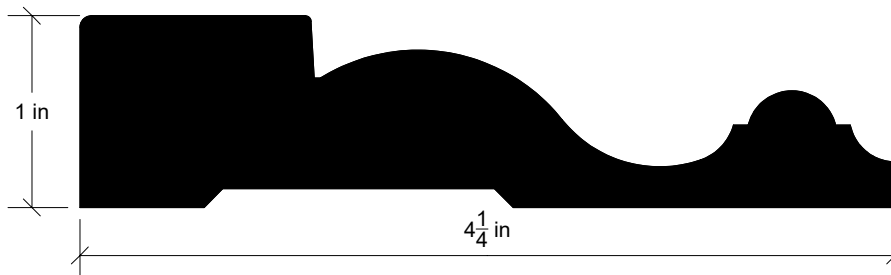

RBM Cas425-006

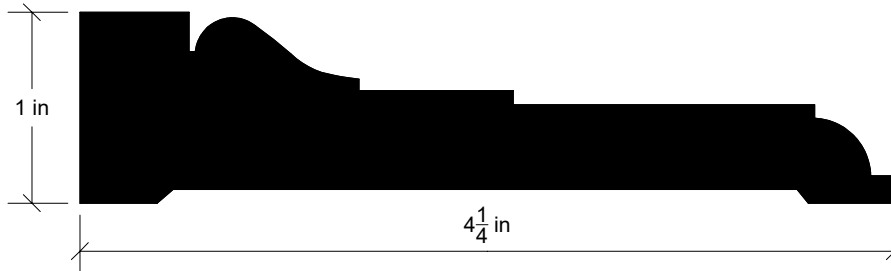

RBMcas425-007

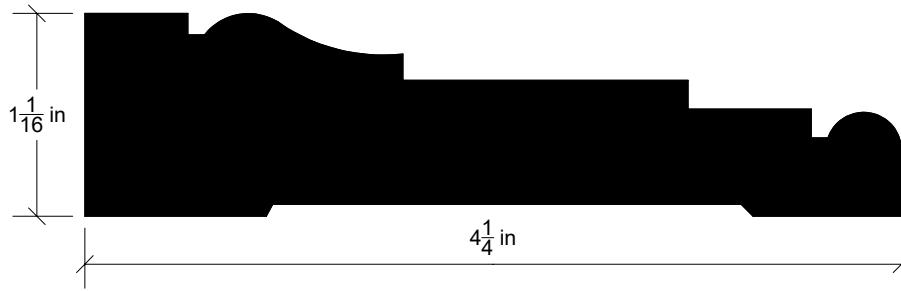

RBM Cas425-008

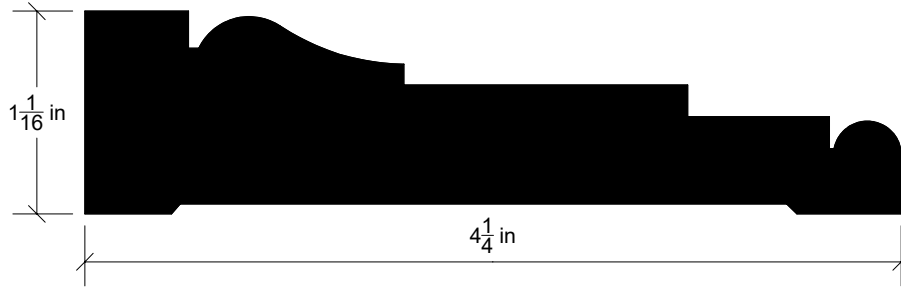

RBM Cas450-001

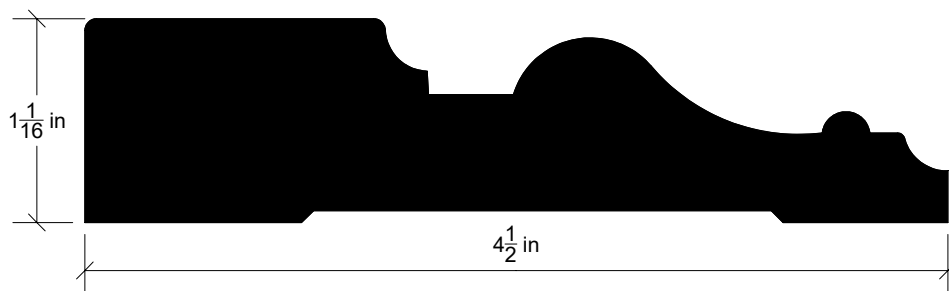

RBM Cas450-002

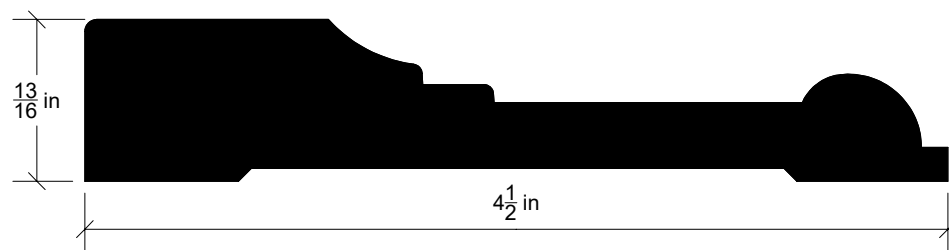

RBM Cas450-003

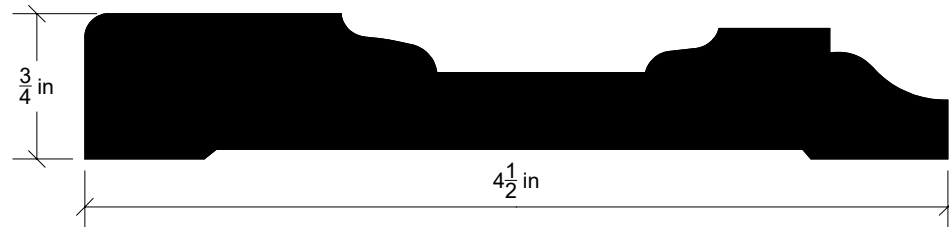

RBM Cas450-004

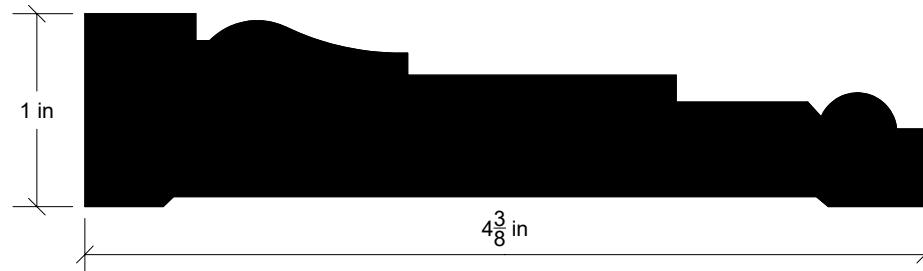

Casing

RBM Cas450-005

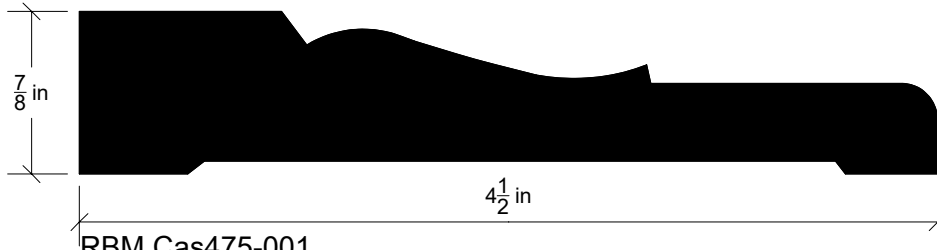

RBM Cas475-001

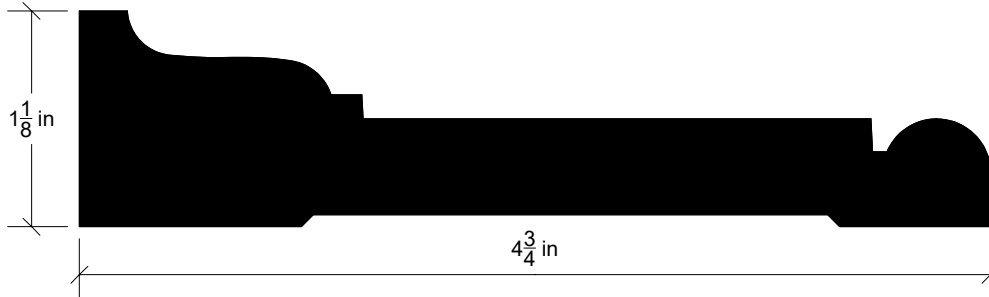

RBM Cas500-001

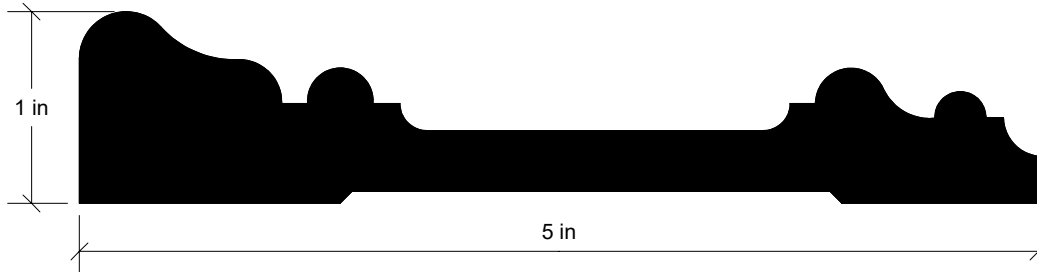

RBM Cas500-002



RBM Cas550-001

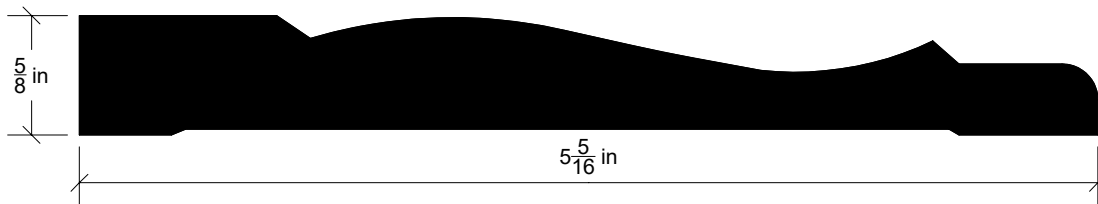

RBM Cas550-002

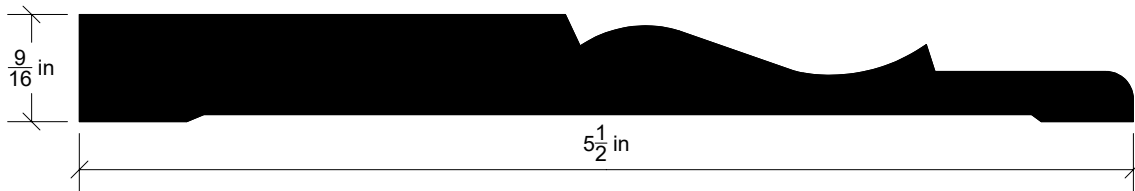

RBM Chr175-001

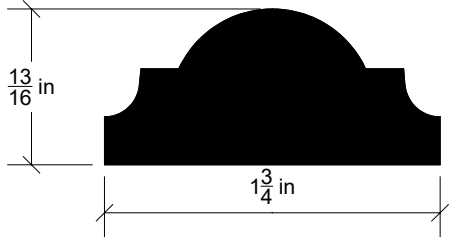

RBM Chr225-001

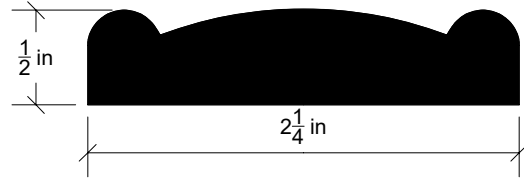

RBM Chr175-002

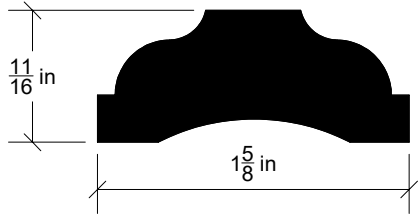

RBM Chr225-002

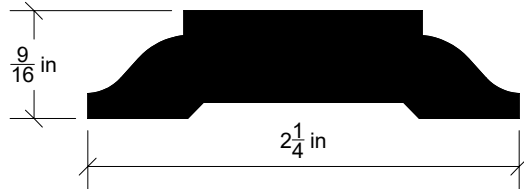

RBM Chr175-003

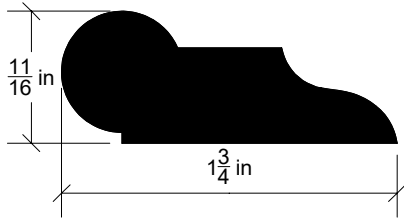

RBM Chr225-003

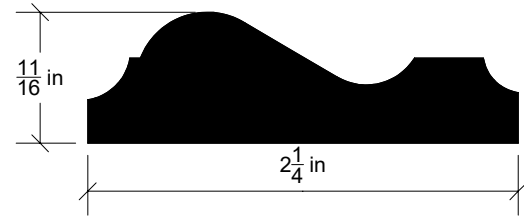

RBM Chr175-004

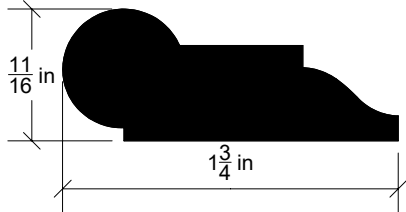

RBM Chr250-001

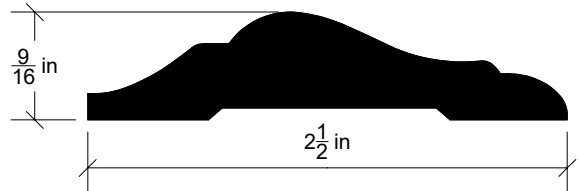

RBM Chr200-001

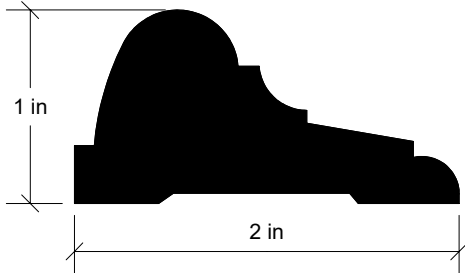

RBM Chr250-002

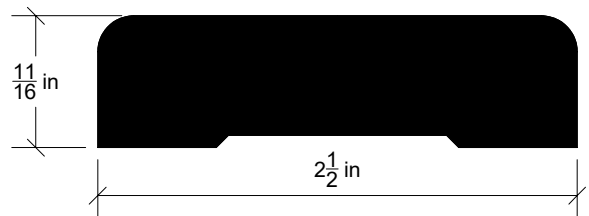

RBM Chr250-003

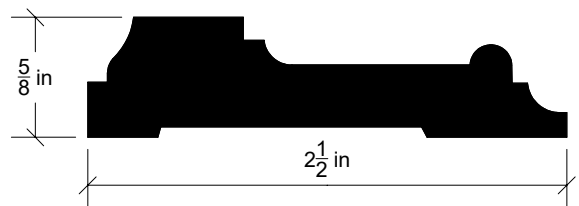

Chair Rail

RBM Chr275-001

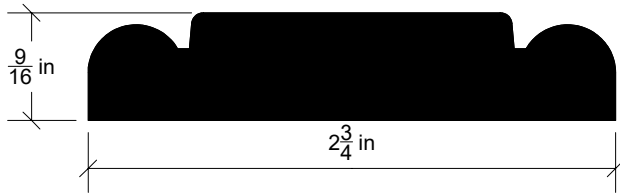

RBM Chr300-001

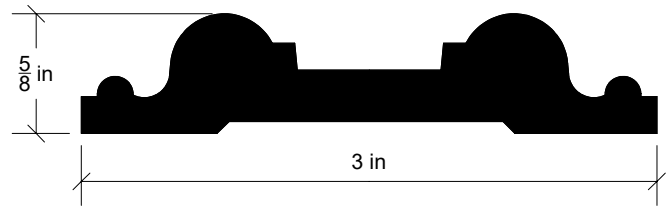

RBM Chr275-002

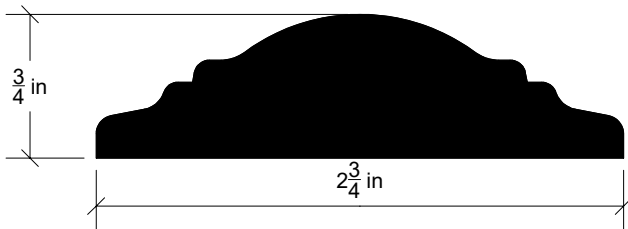

RBM Chr300-002

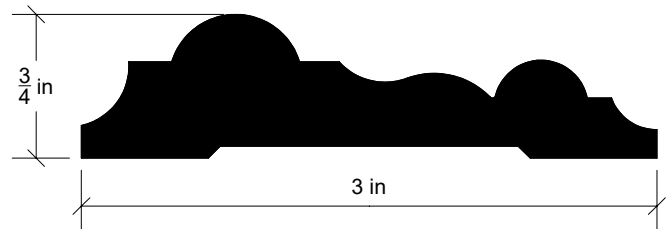

RBM Chr275-003

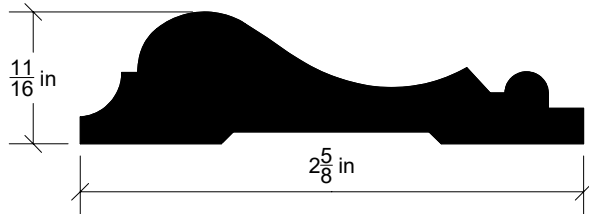

RBM Chr300-003

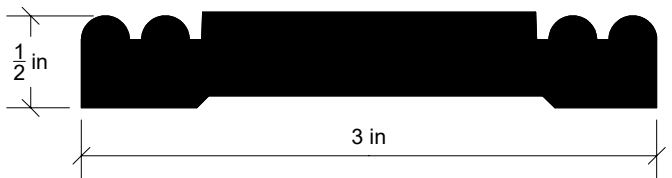

RBM Chr275-004

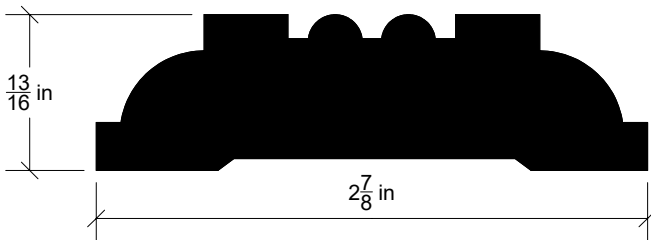

RBM Chr300-004

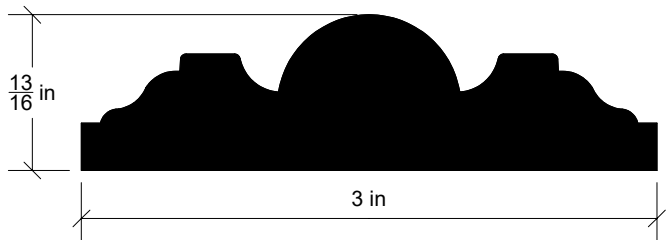

RBM Chr275-005

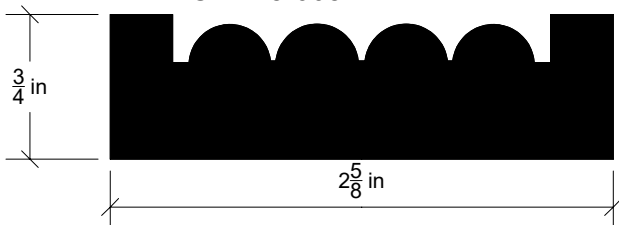

RBM Chr300-005

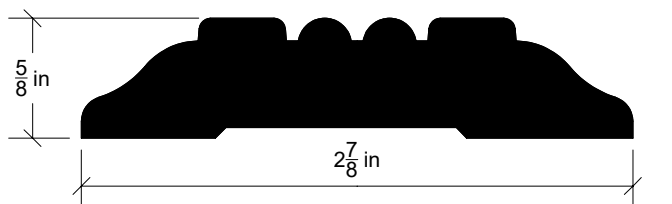

Chair Rail

RBM Chr300-006

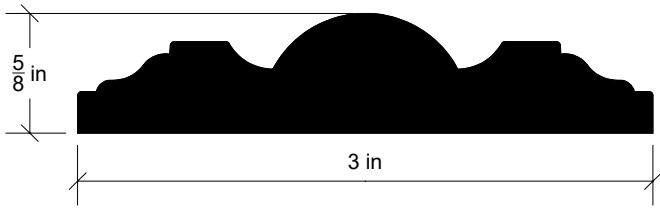

RBM Chr300-007

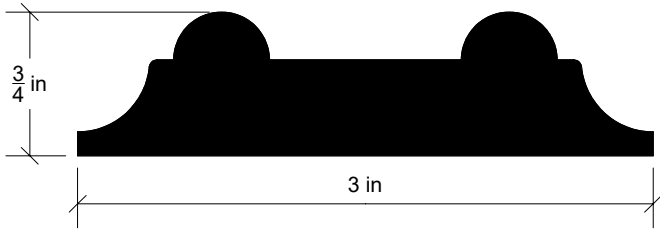

RBM Chr300-008

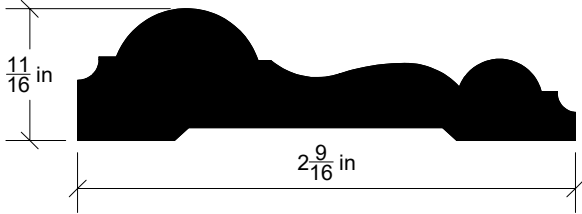

RBM Chr300-009

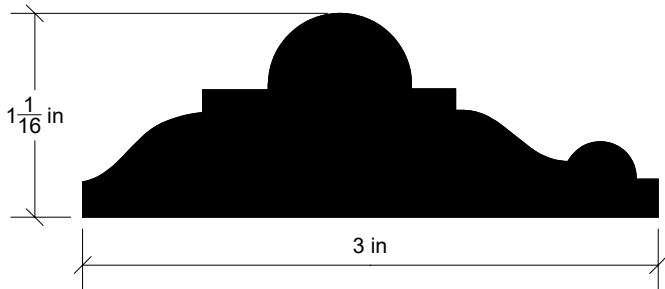

RBM Chr300-010

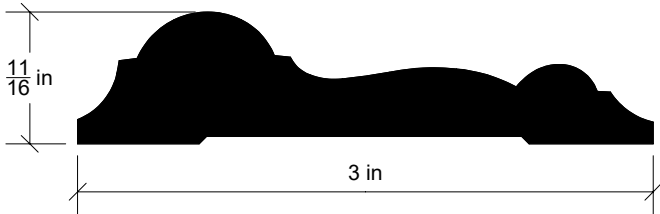

RBM Chr300-011

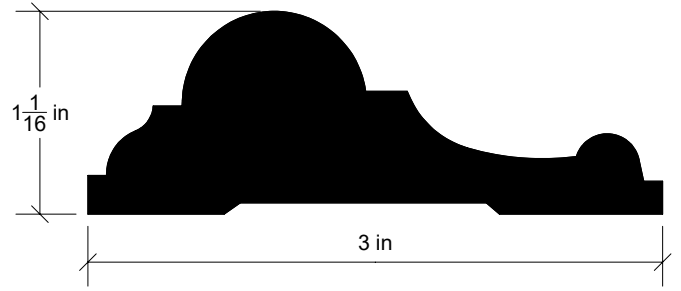

RBM Chr300-012

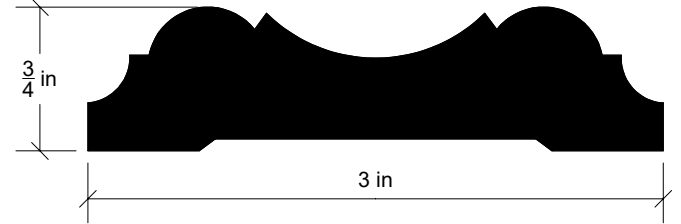

RBM Chr300-013

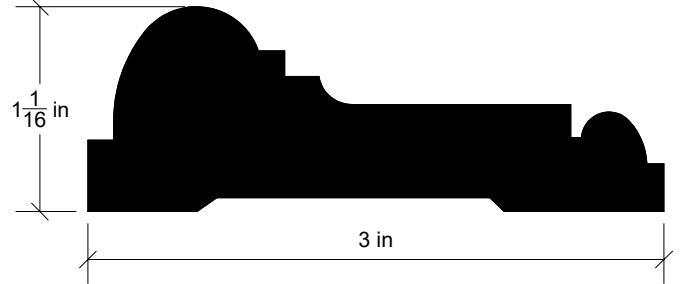

RBM Chr300-014

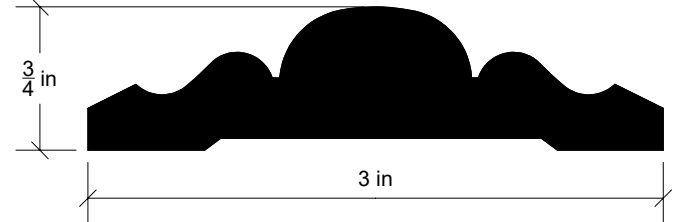

RBM Chr300-015

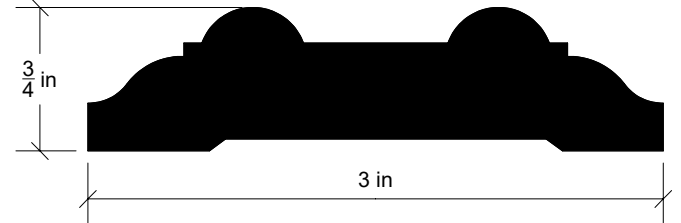

RBM Chr300-016

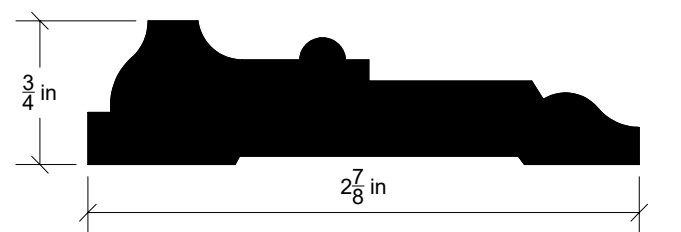

Chair Rail

RBM Chr325-001

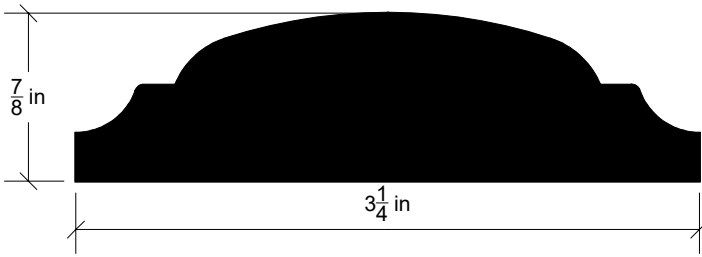

RBM Chr325-006

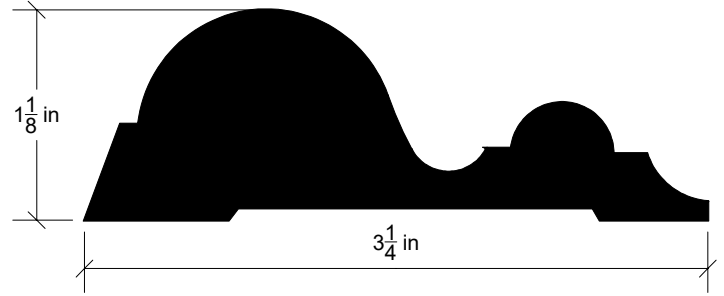

RBM Chr325-002

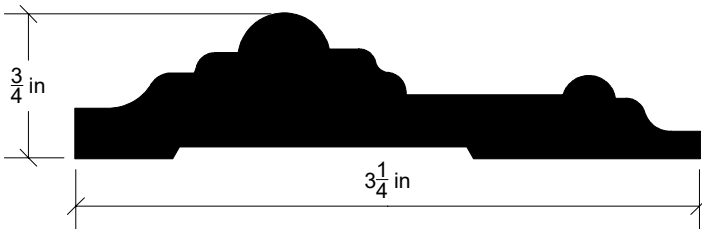

RBM Chr325-007

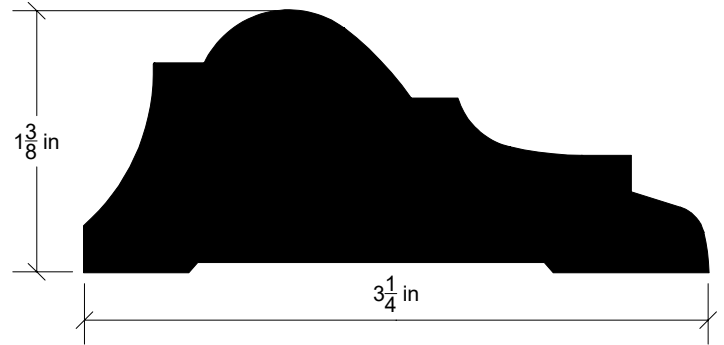

RBM Chr325-003

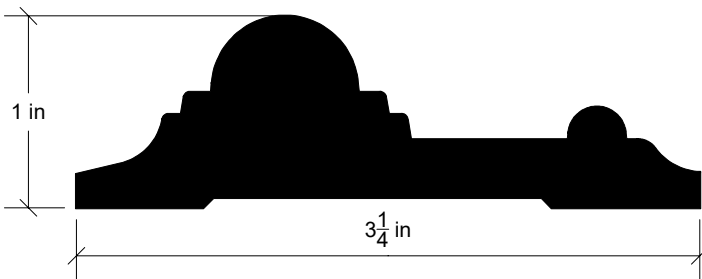

RBM Chr350-001

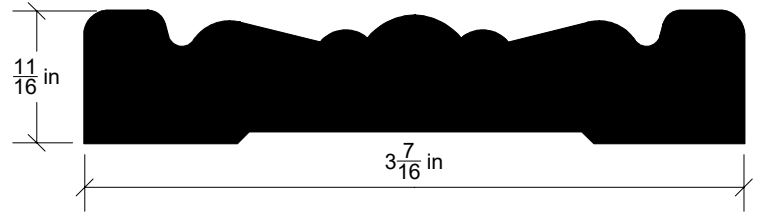

RBM Chr325-004

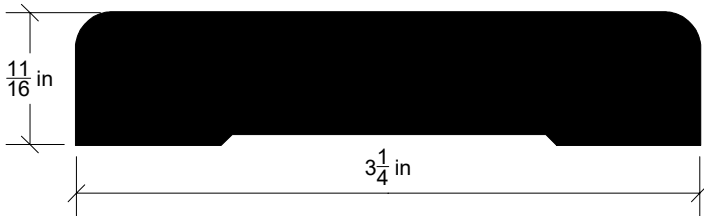

RBM Chr350-002

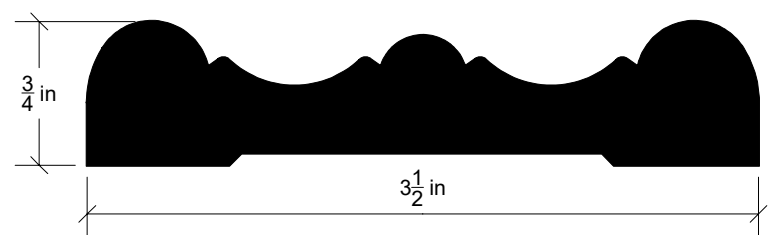

RBM Chr325-005

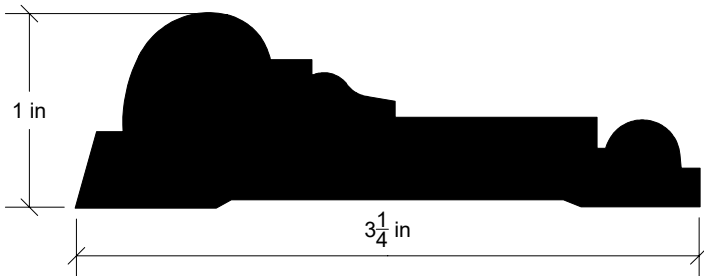

RBM Chr350-003

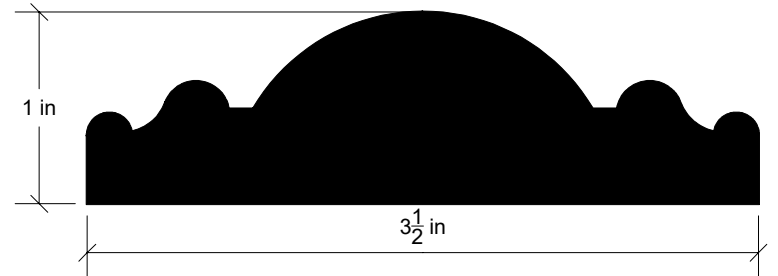

RBM Chr350-004

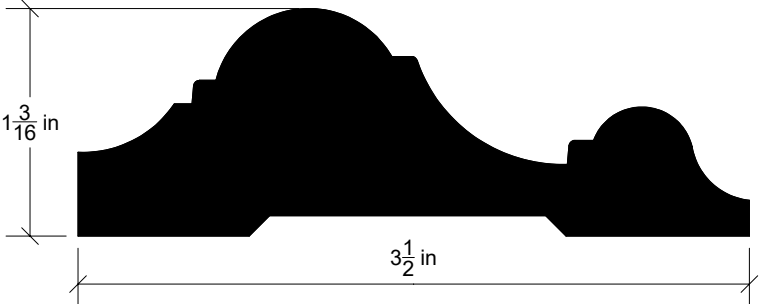

RBM Chr400-002

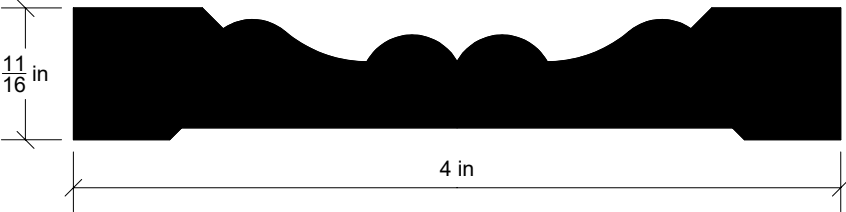

RBM Chr375-001

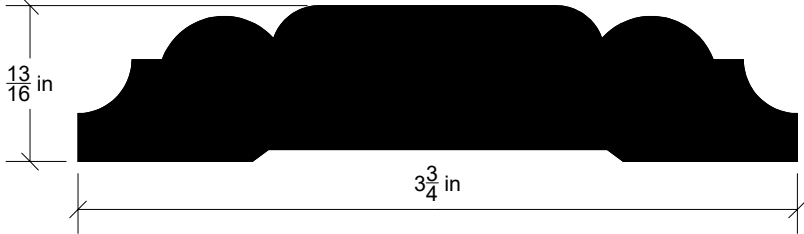

RBM Chr400-003

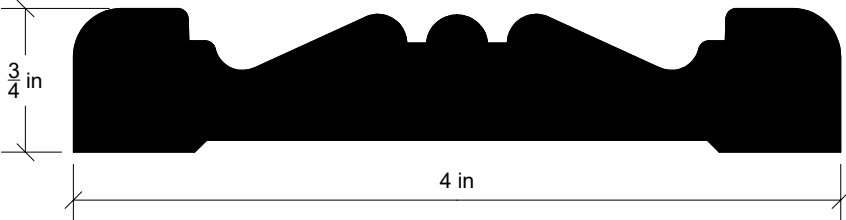

RBM Chr400-001

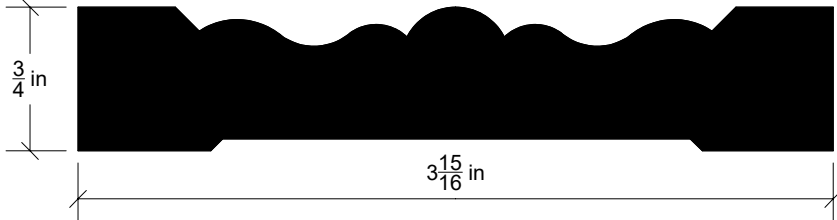

RBM Chr400-004

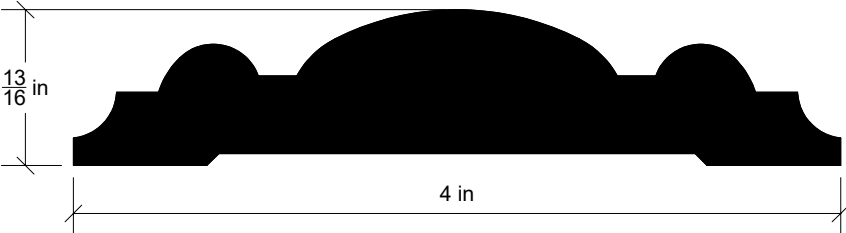

Chair Rail

RBM Chr400-005

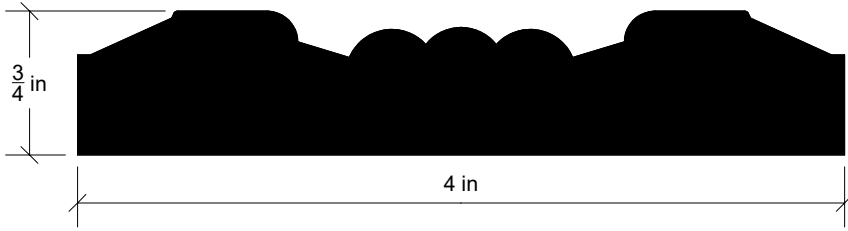

RBM Chr450-001

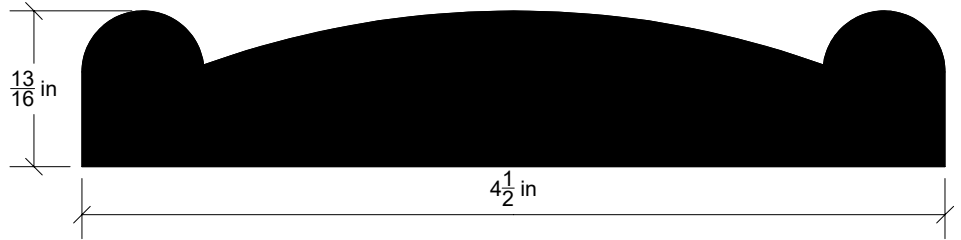

RBM Chr400-006

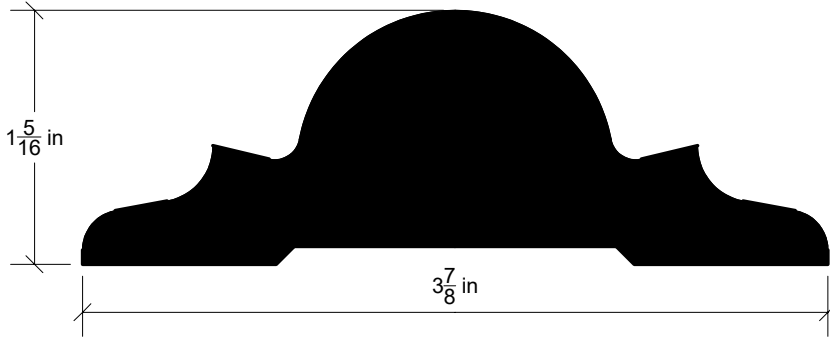

RBM Chr450-002

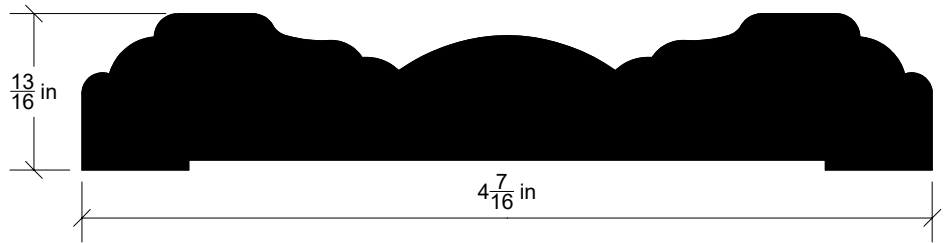

RBM Chr425-001

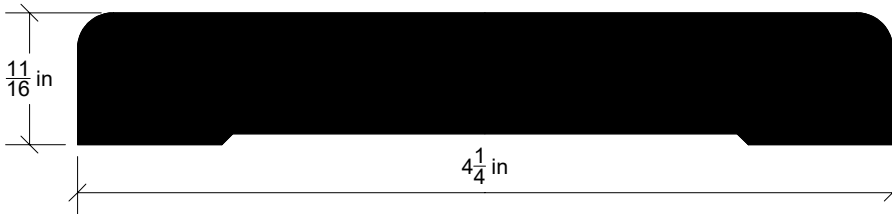

RBM Chr475-001

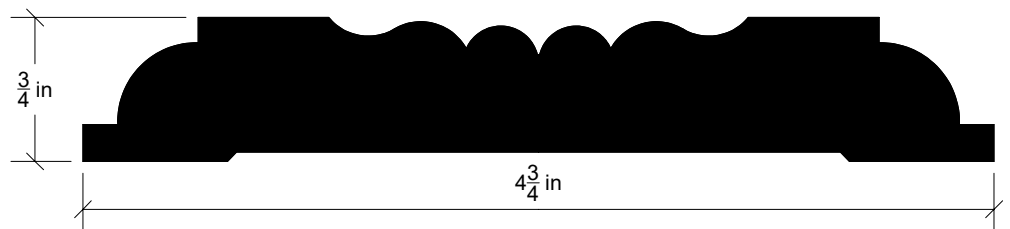

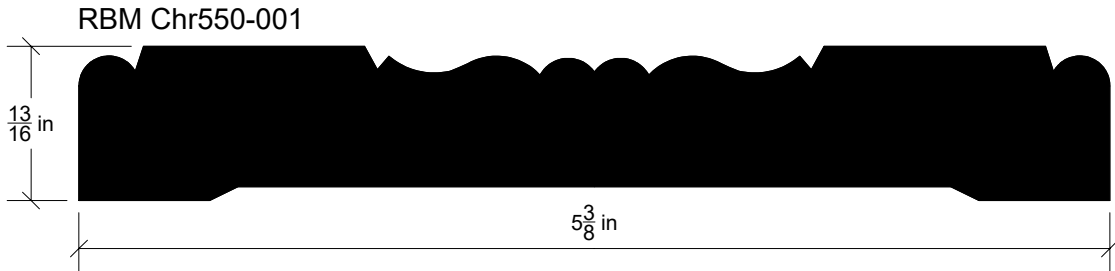
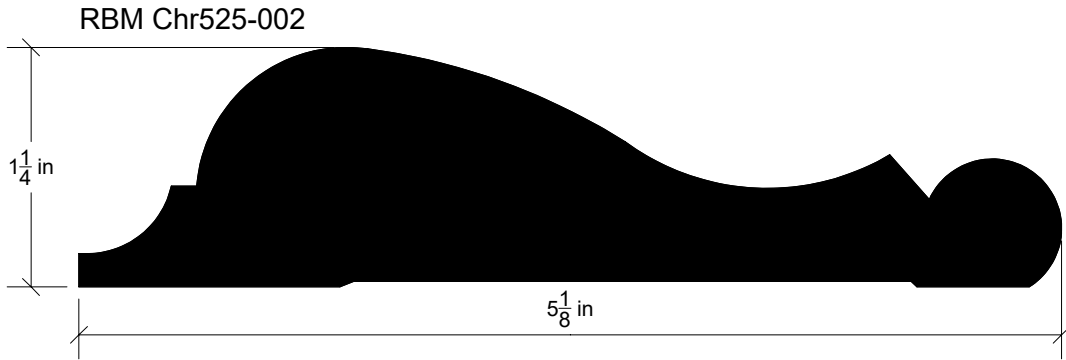
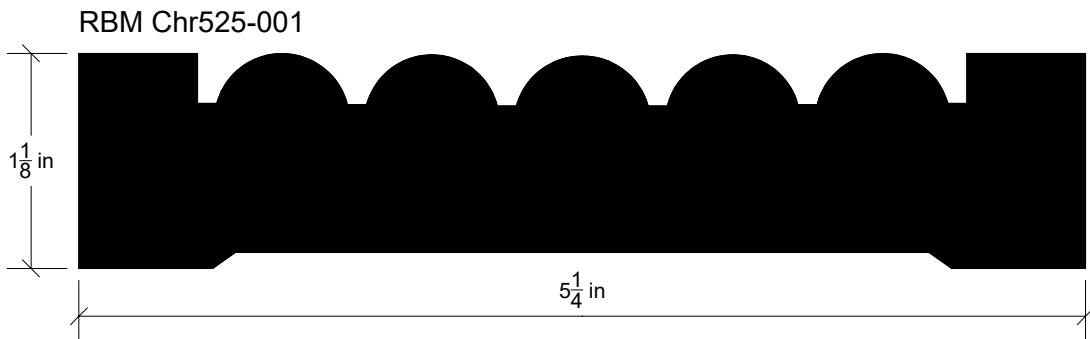
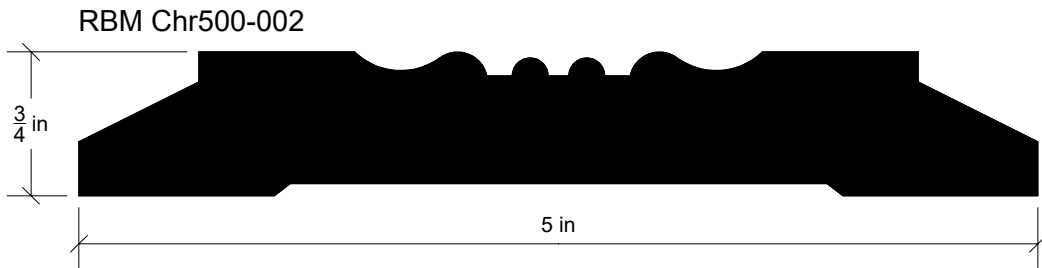
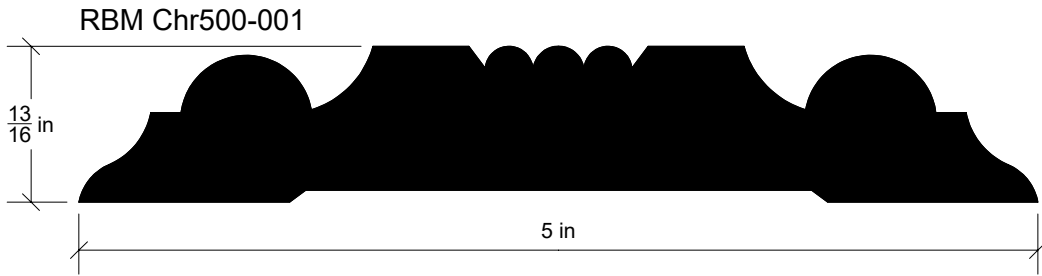

Applied Finished Corners

We can customize corners to your needs.
Any size, bevel outside, chamber radius, etc.

Standard wall thickness is 10mm (0.38").
Standard outside edge is 2mm.

For custom sizes,
please provide both
inside & outside
measurements

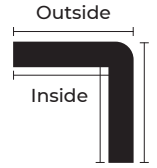

RBM AFCR-34

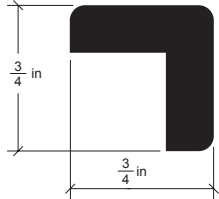

RBM AFCR-78

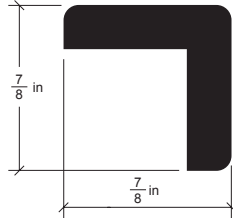

RBM AFCR-11

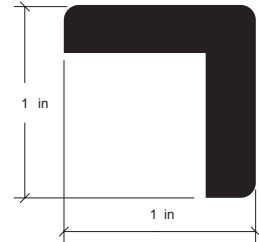

RBM AFCR-116

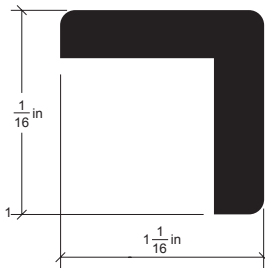

RBM AFCR-118

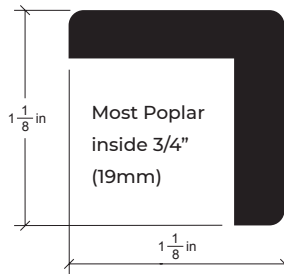

RBM AFCR-134

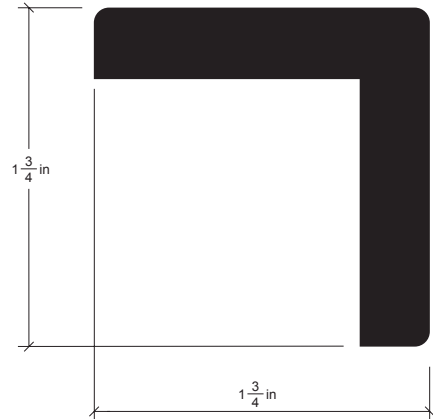

45°



RBM AFCR-45D-1-1

45°

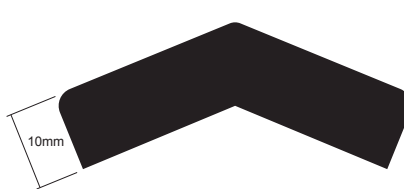

RBM AFCR-45D.75-.75

Angles are customizable
to fit your project

Applied Finished Inside Corners



RBM AFICR-12



RBM AFICR-9

Applied finished inside corners are available
to accommodate for any baseboard thickness.



This is considered a radius front

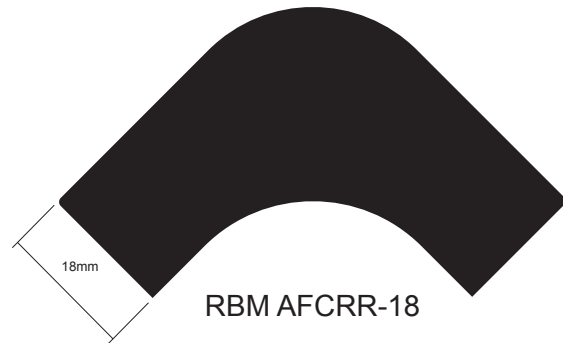
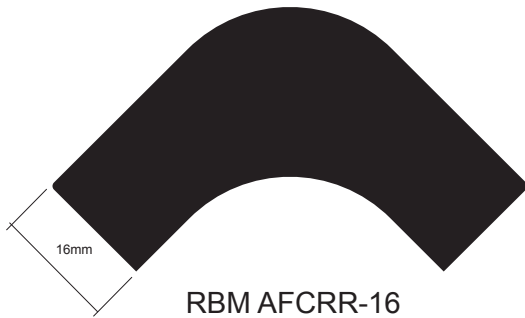
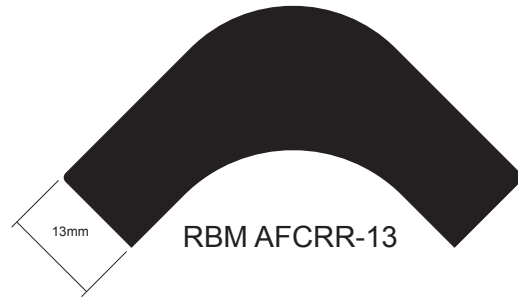

RBM AFCRD

Diagonal front available on all Applied Finished Outside Corners - as shown here

Applied outside finished corners are available in any wall thickness.

All outside edges comes standard with 1mm radius.

**Don't see exactly what you're looking for?
Contact us!**

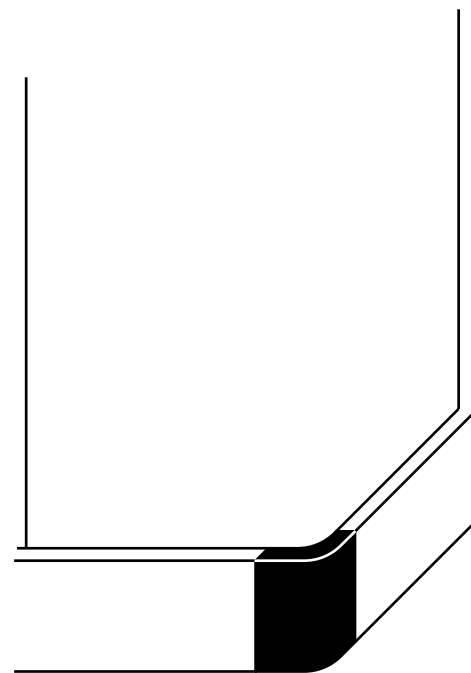

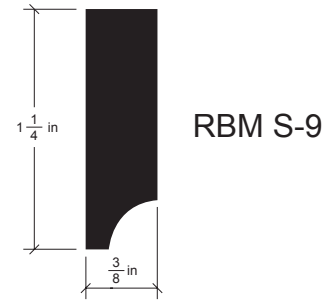
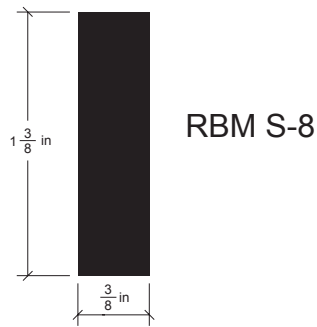
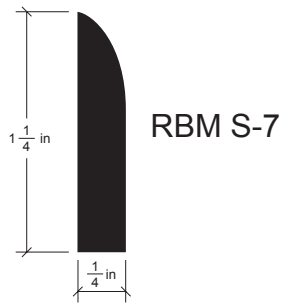
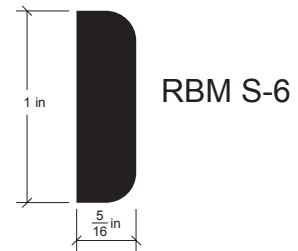
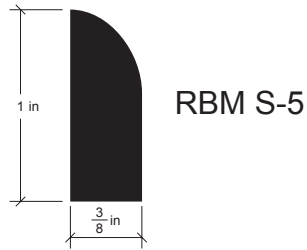
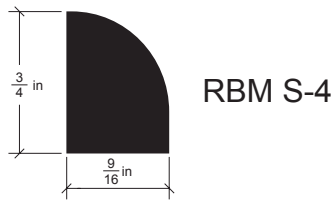
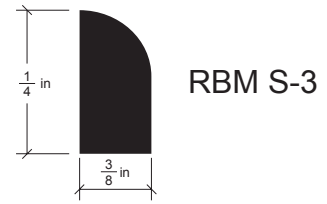
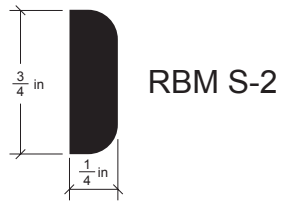
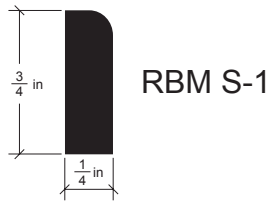

RBM S-10

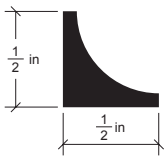

RBM S-11

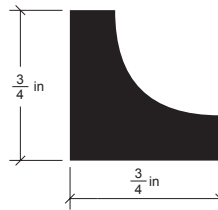

RBM S-12

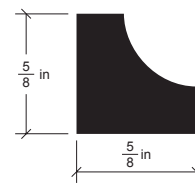

RBM S-13

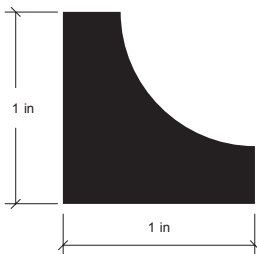

RBM S-14

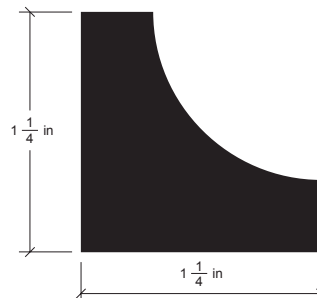

RBM S-15

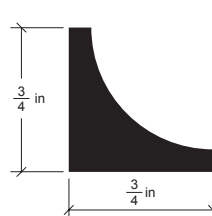

Tongue & Groove moulding is available in any size or thickness.

RBM T&G-214

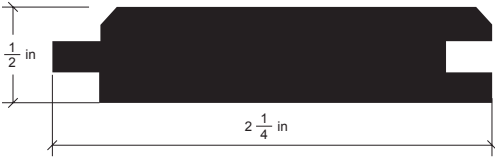

RBM T&G-212

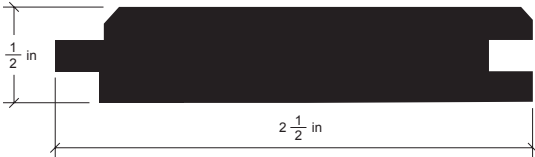

RBM T&G-234

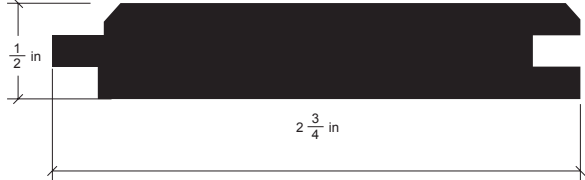

RBM T&G-35

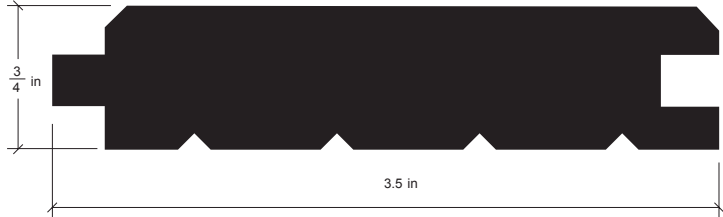

If transition strips are required, please let us know and we will make it to your specifications.

RBM T&G-4

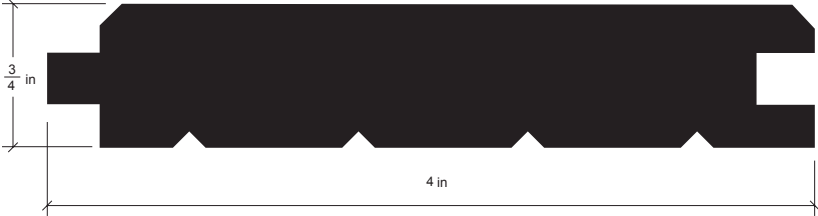

RBM T&G-45

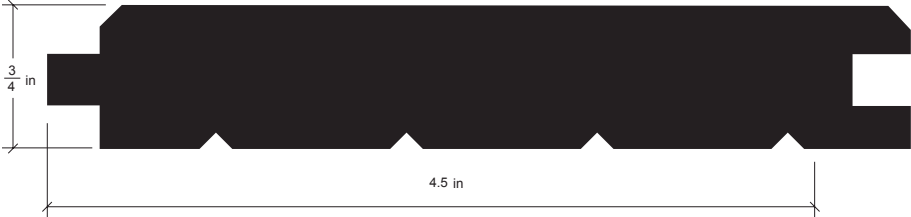

RBM T&G-525

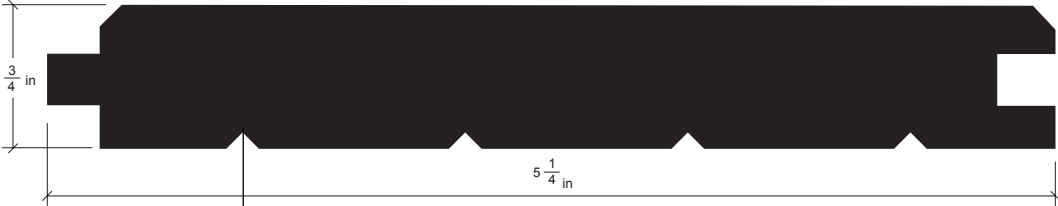

Stress cutouts on back side optional

RBM HR-150 **MOST POPULAR**

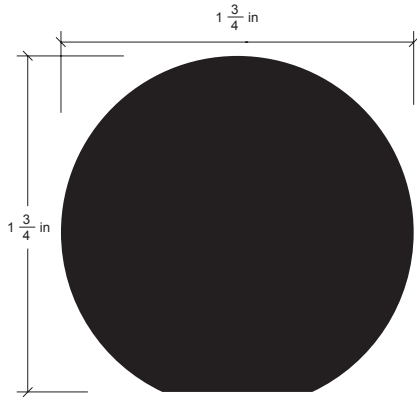

RBM HR-1P **MOST POPULAR**

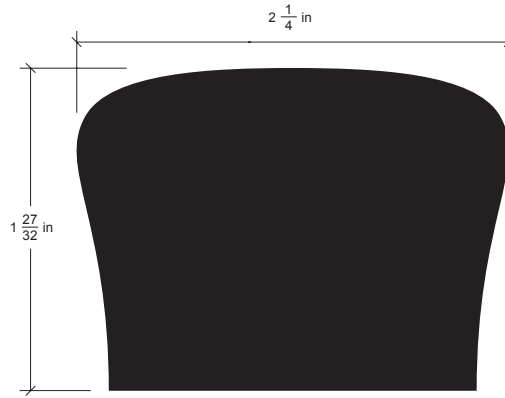

RBM HR-45 **MOST POPULAR**

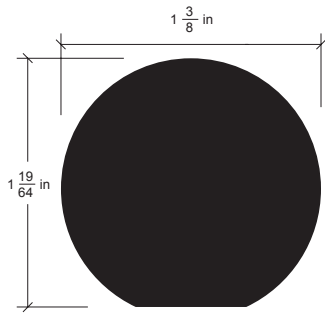

Fits Standard Coffin Carry handle Bracket

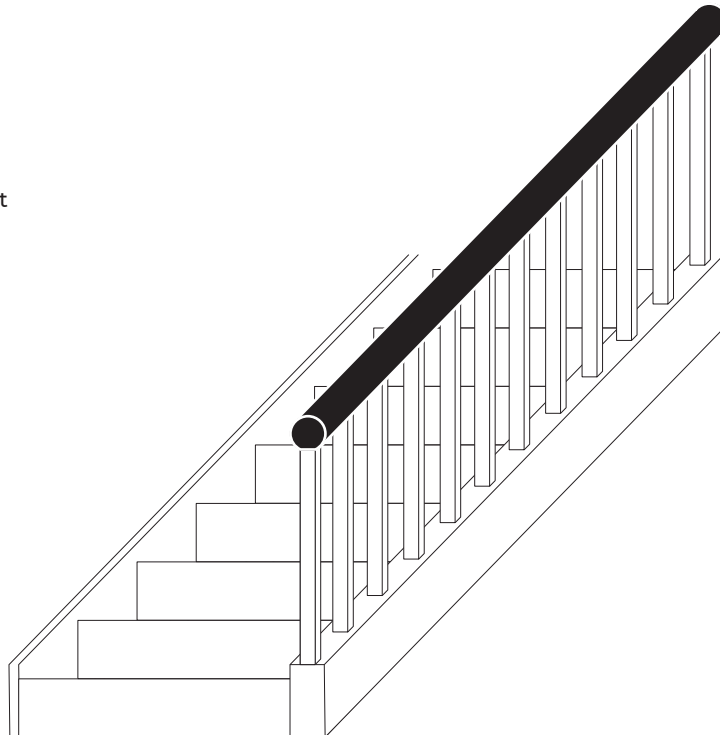

RBM HR-1

MOST POPULAR

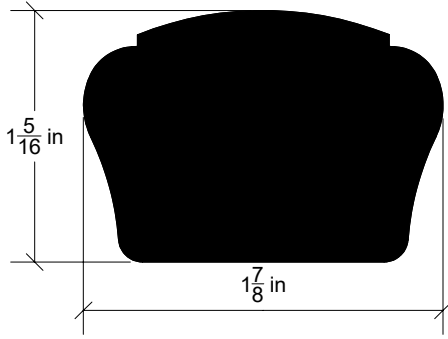

RBM HR-2

Rail

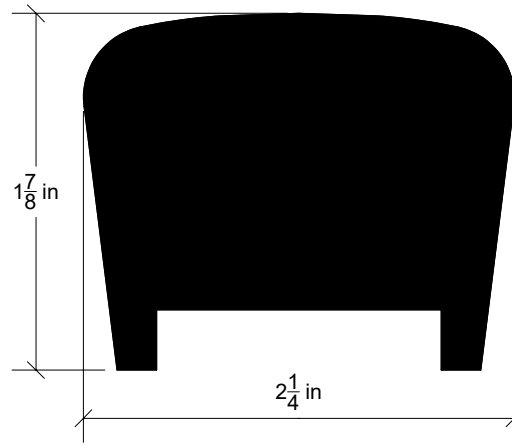

RBM HR-3

MOST POPULAR

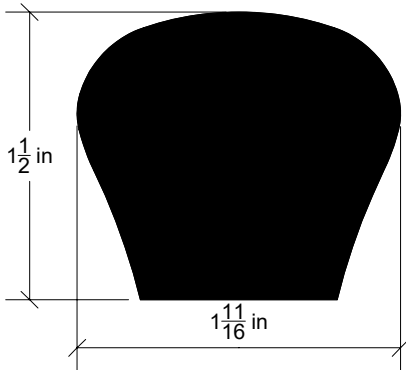

RBM HR-4

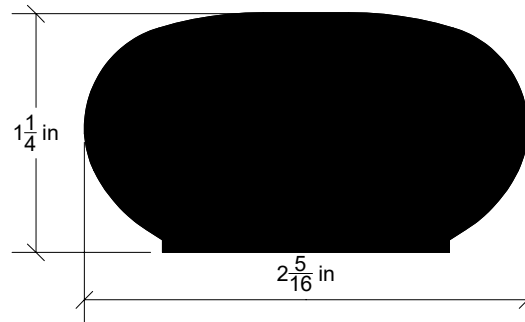

RBM HR-5

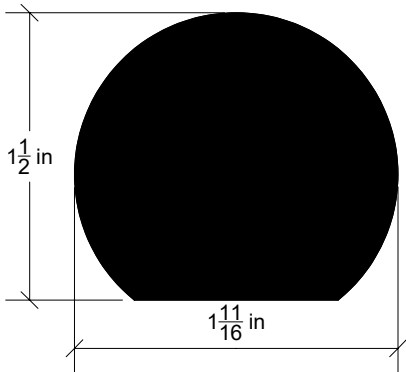

RBM HR-6

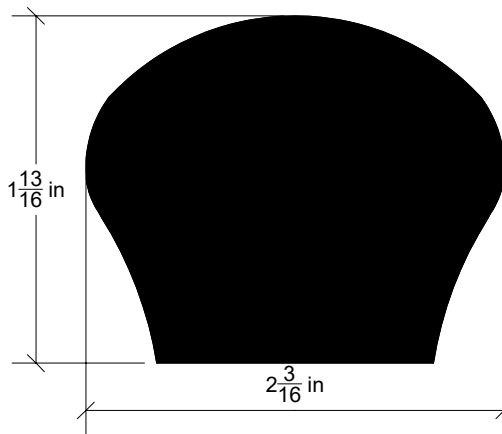

RBM HR-7

MOST POPULAR

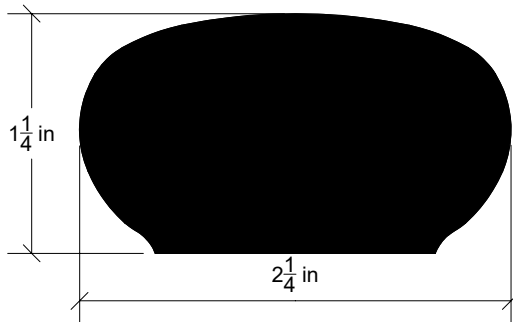

RBM HR-8

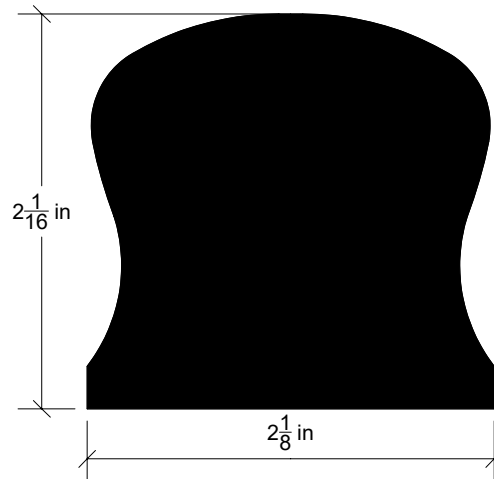

Need cut to length? Angle on ends? Let us know!

RBM HR-9

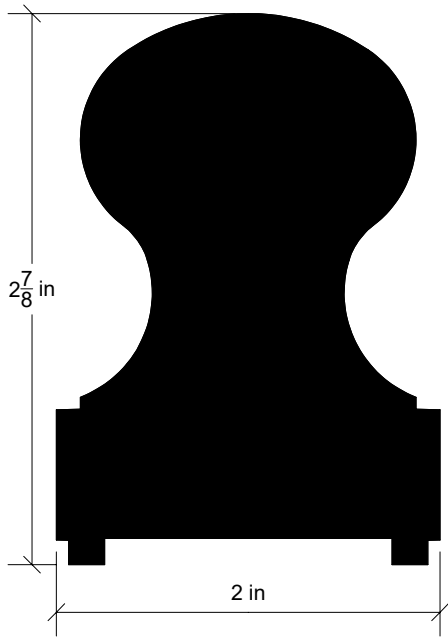

RBM HR-10

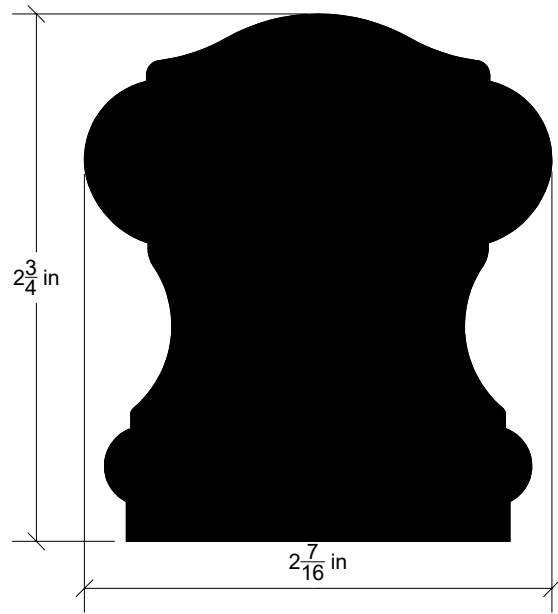

RBM HR-11

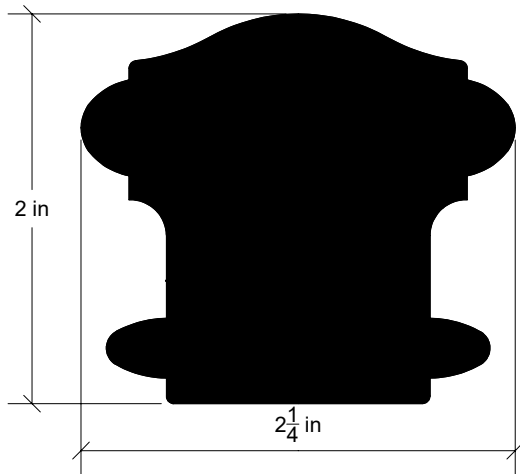

RBM HR-12

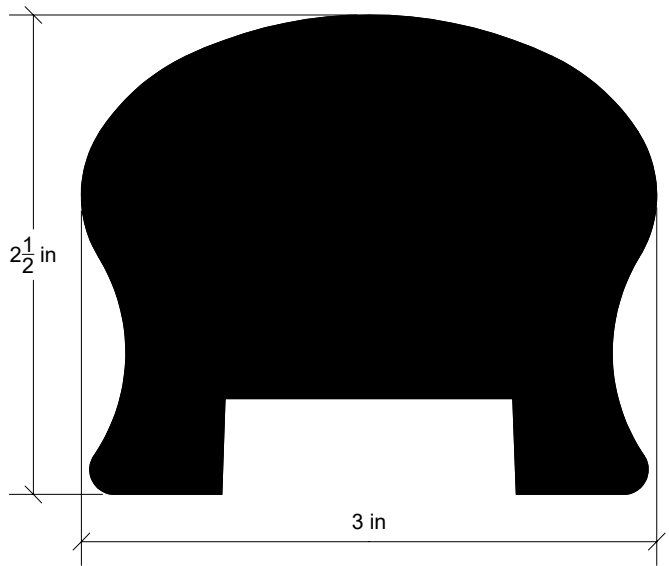

RBM HR-13

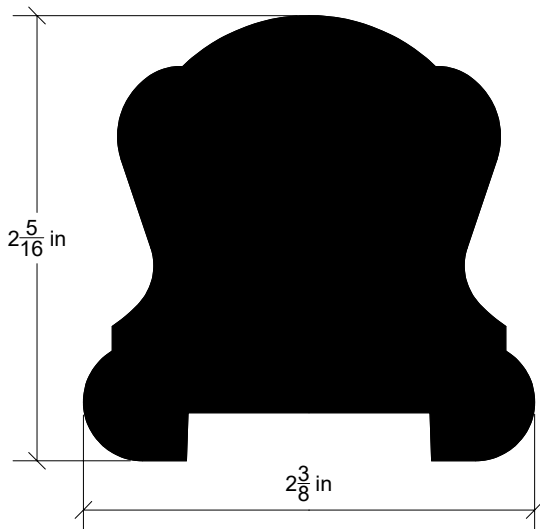

RBM HR-14

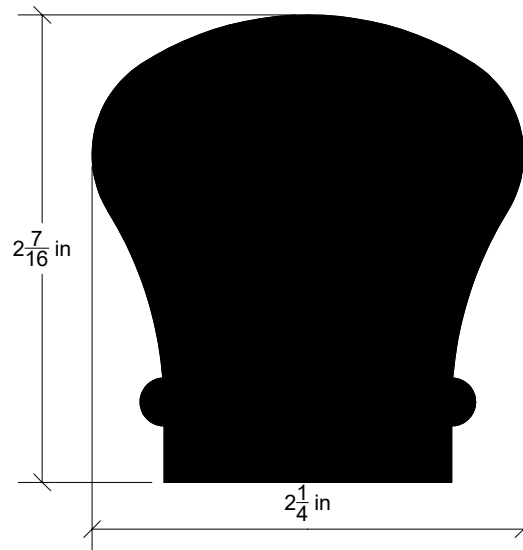

RBM HR-15

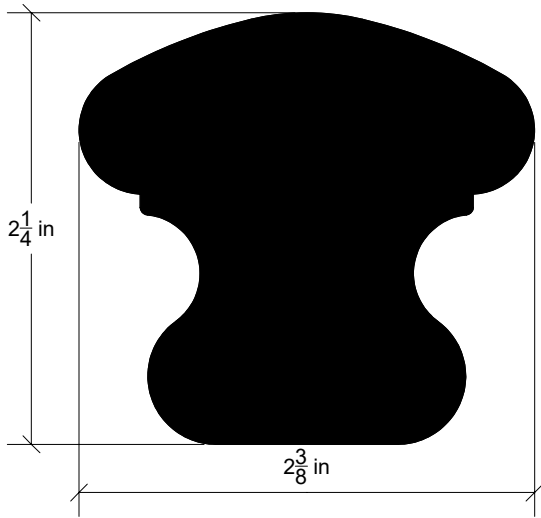

RBM HR-16

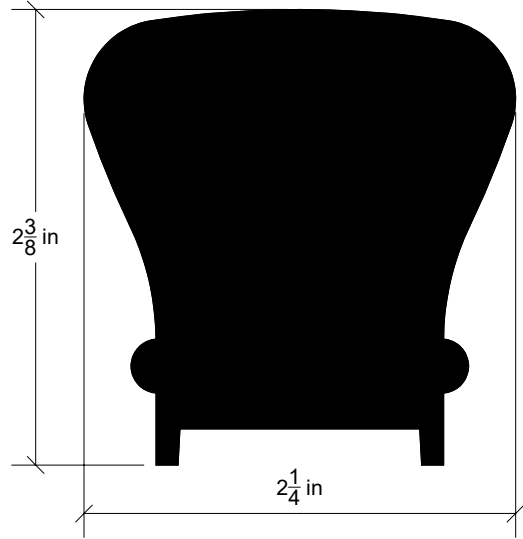

RBM HR-17

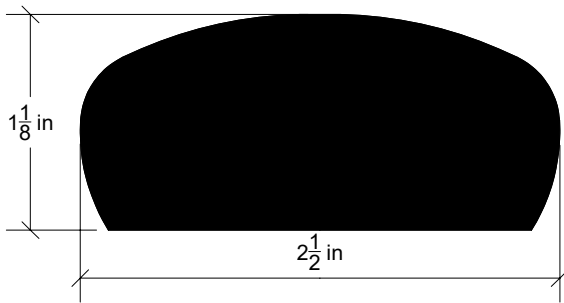

RBM HR-18

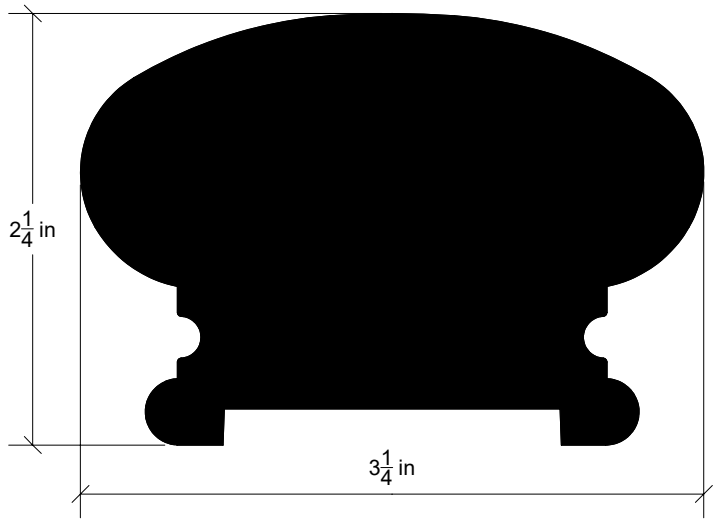

RBM HR-19

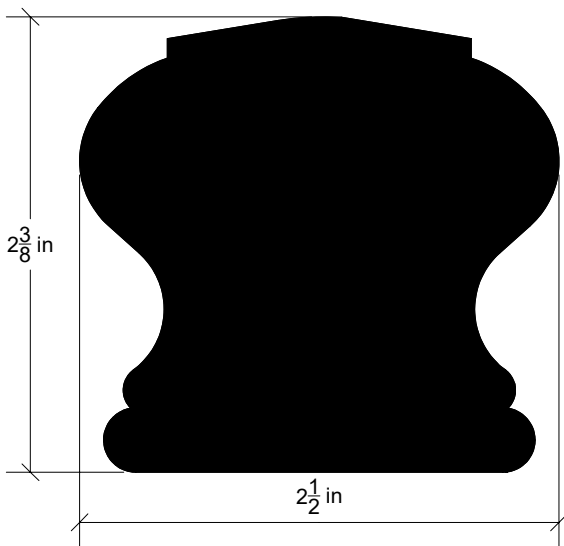

RBM HR-20

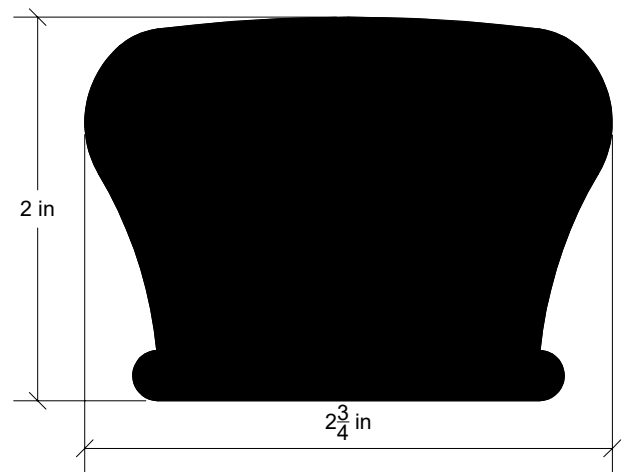

RBM HR-21

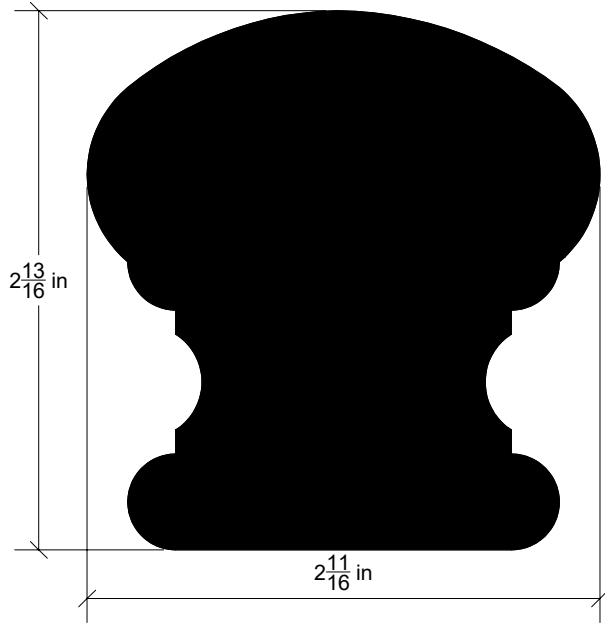

RBM HR-22

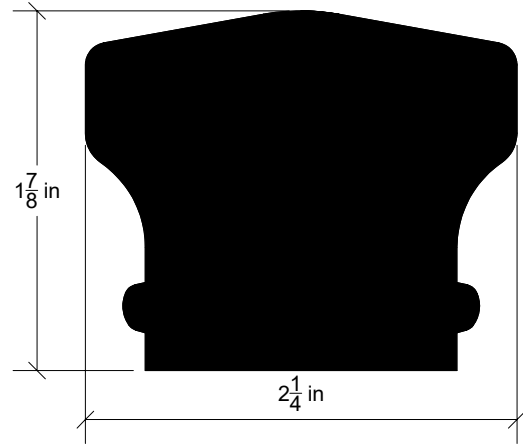

RBM HR-23

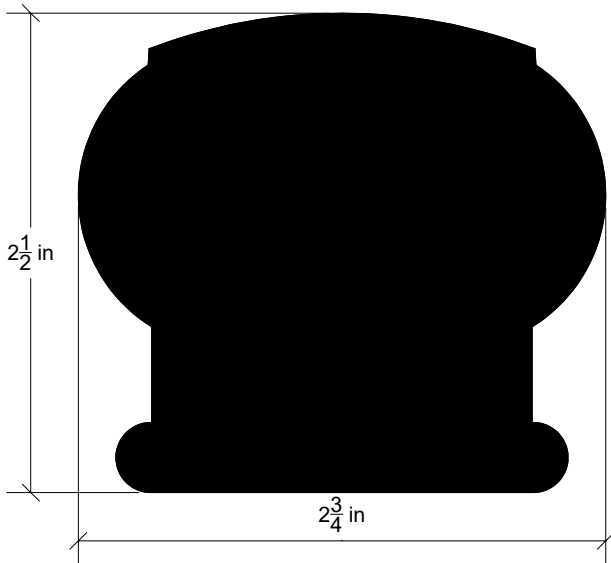

RBM HR-24

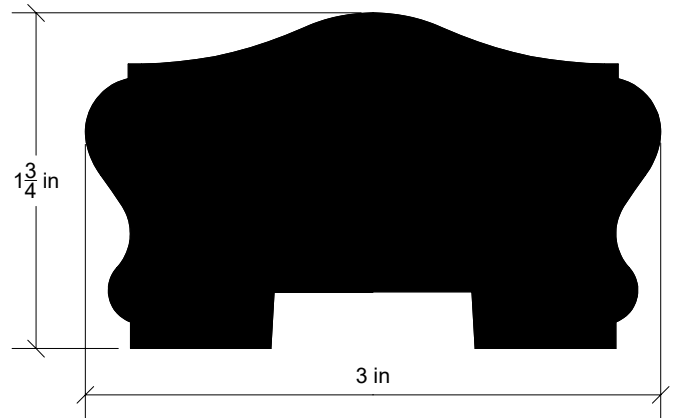

RBM HR-25

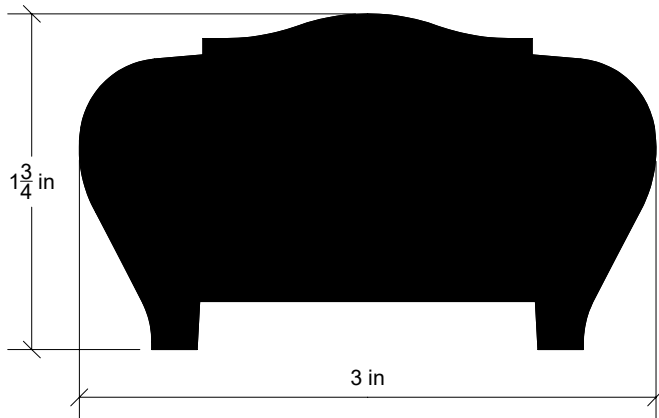

RBM HR-26

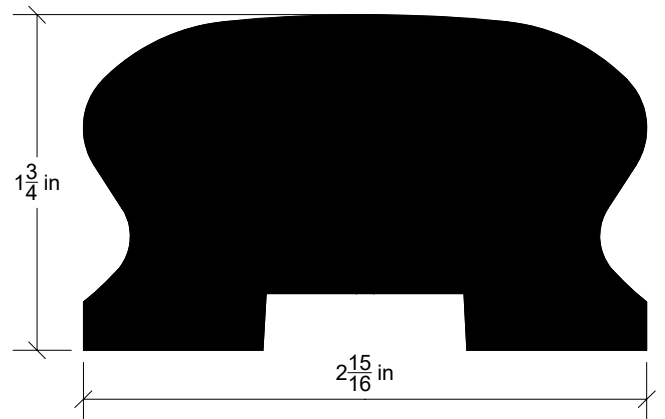

RBM HR-27

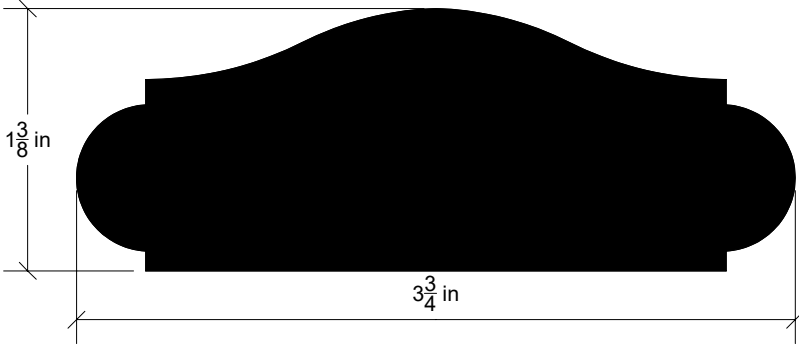

RBM HR-28

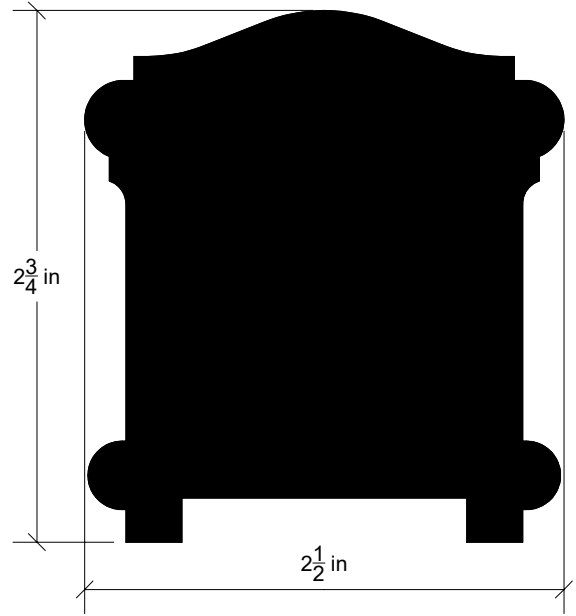

RBM HR-29

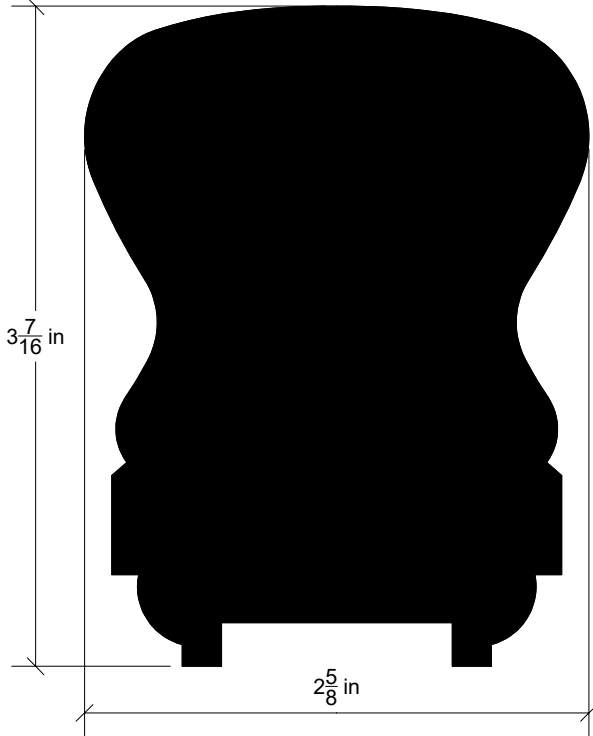

RBM HR-30

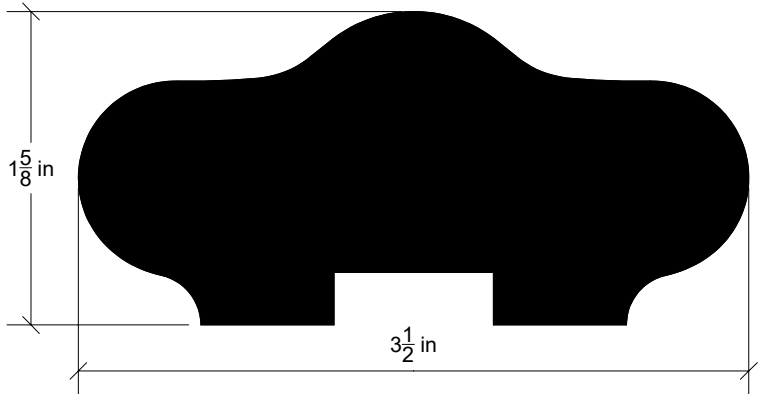

RBM HR-31

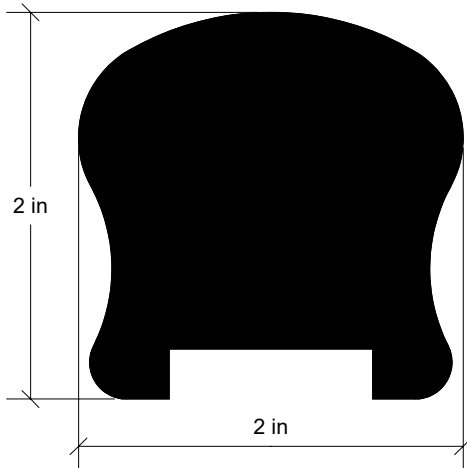

RBM HR-32

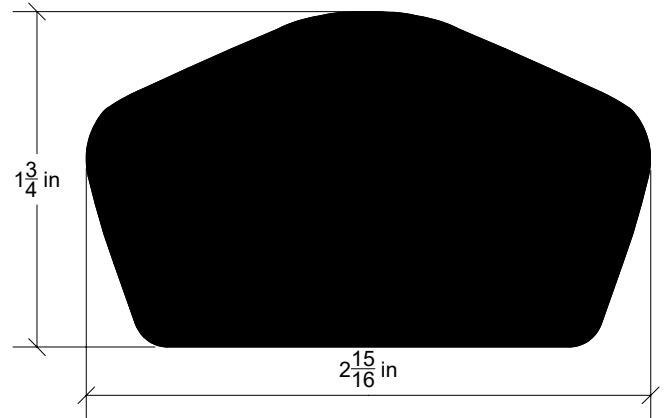

RBM HR-33

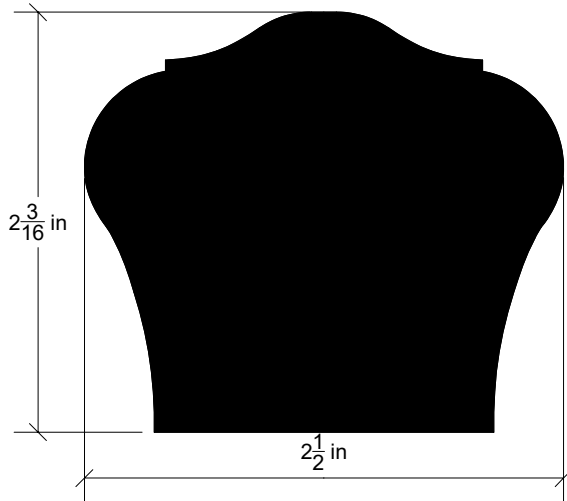

RBM HR-34

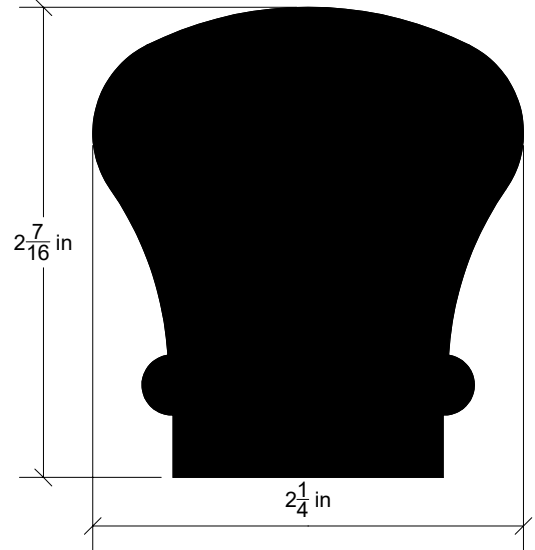

RBM HR-35

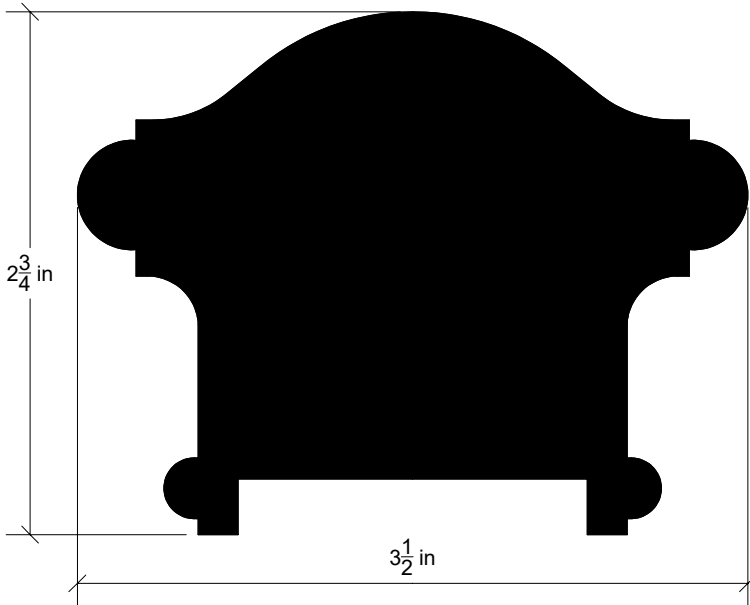

RBM HR-36

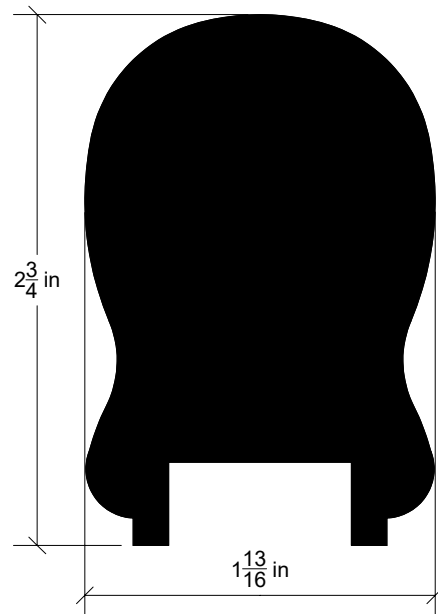

RBM HR-37

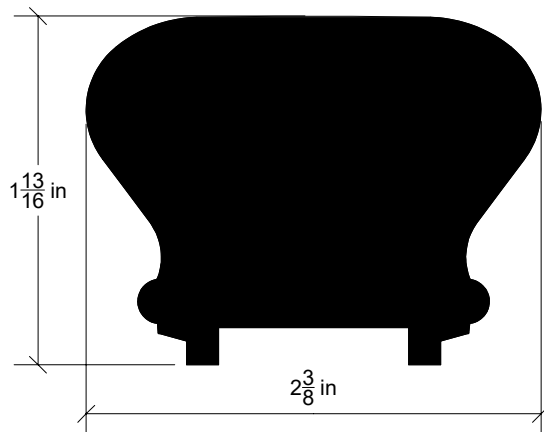

RBM HR-38

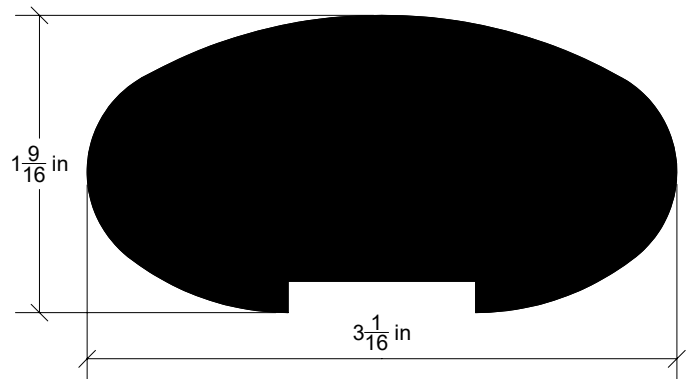

RBM HR-39

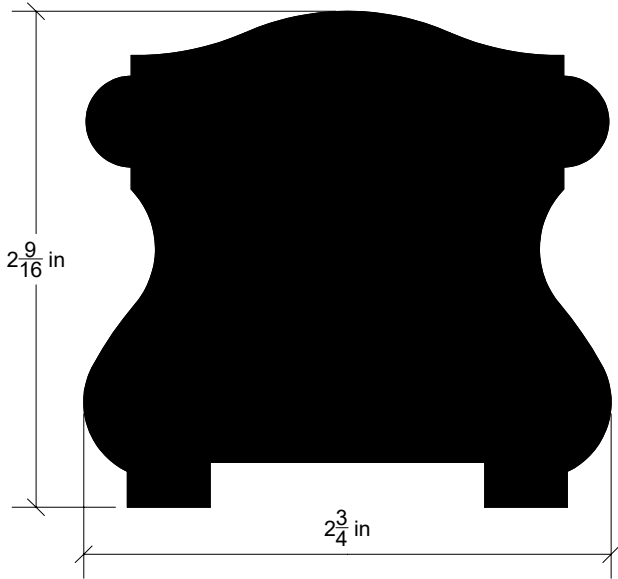

RBM HR-40

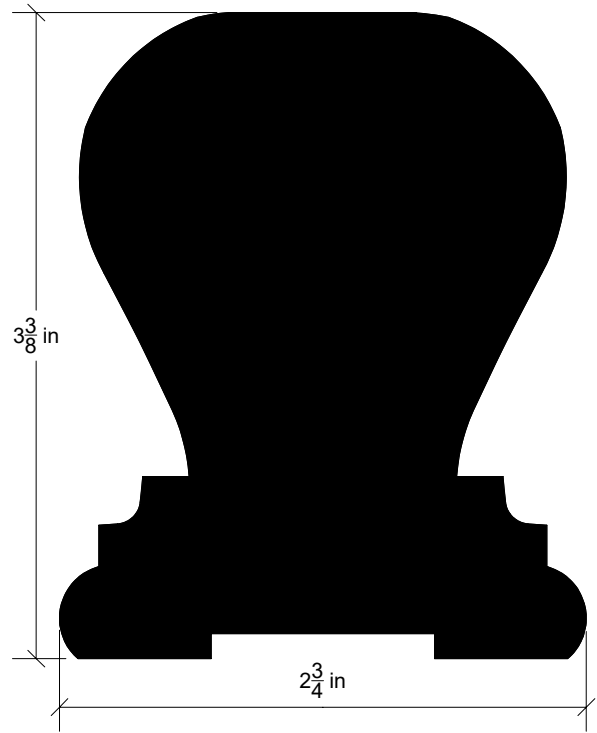

RBM HR-41

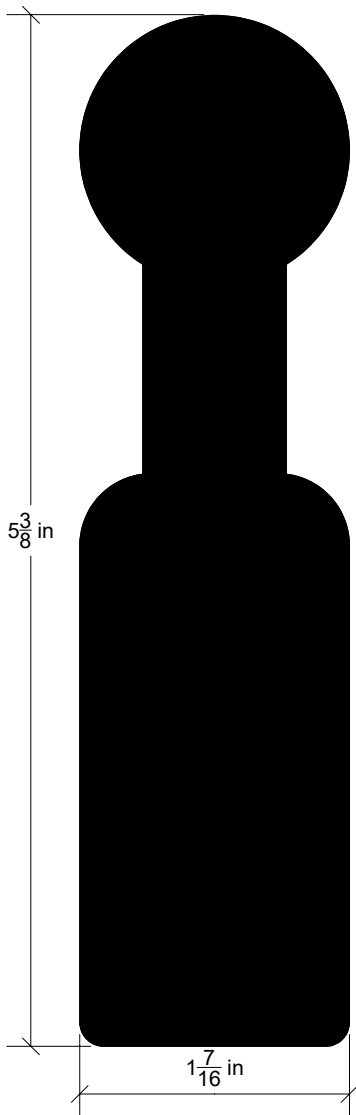

4 ¹/₈ in

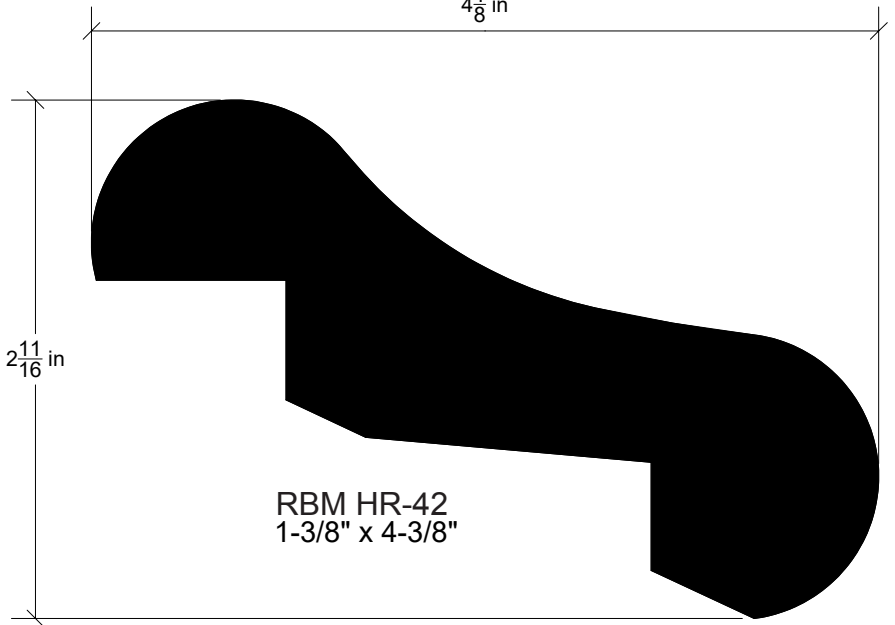

RBM HR-42
1-3/8" x 4-3/8"

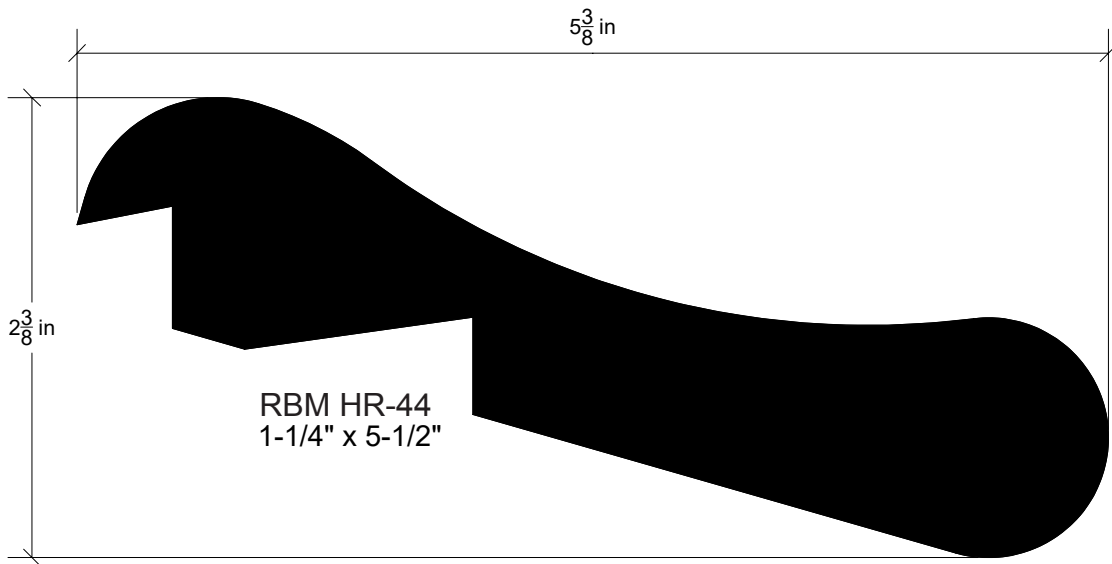
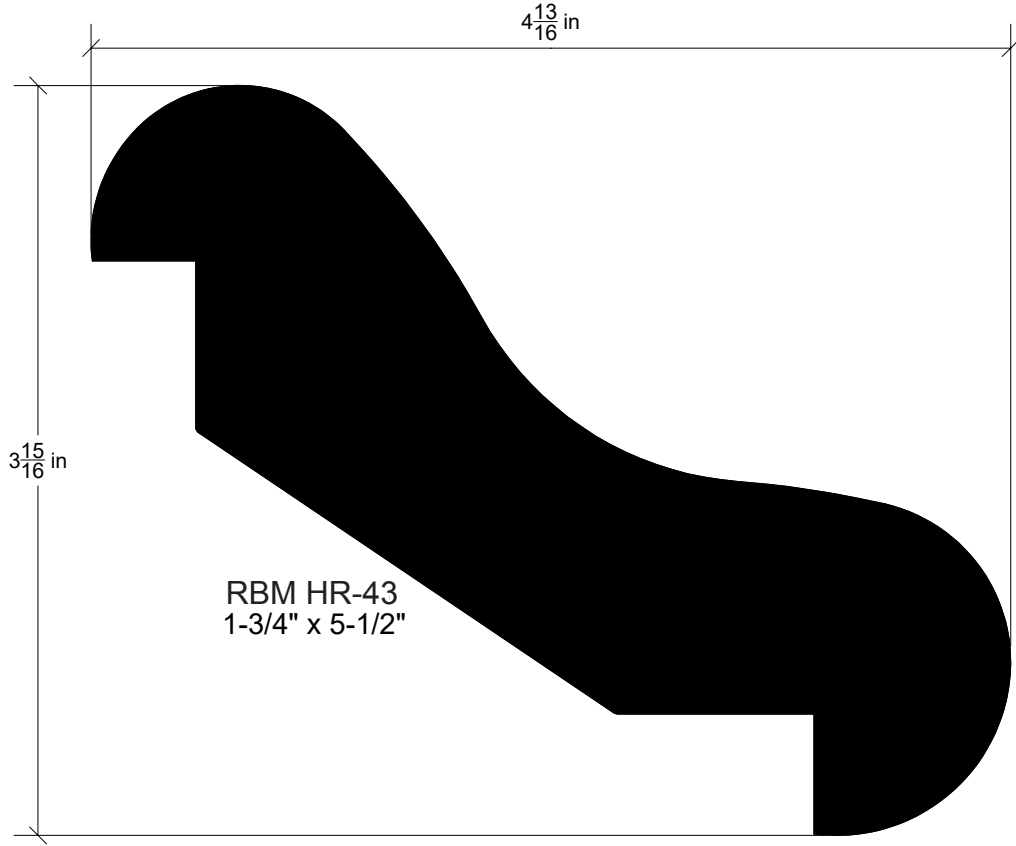

RBM HC-1



RBM HC-2

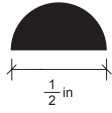

RBM HC-3

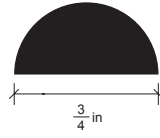

RBM HC-4

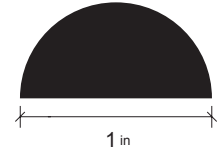

RBM HC-5

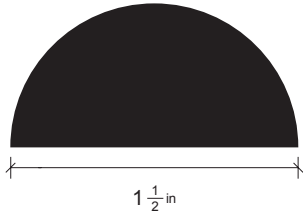

RBM HC-6

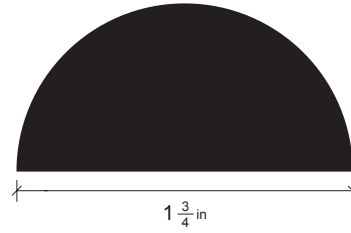

Need a 1/4 or full circle? Let us know and we can quote on sizing and lengths.



1/4

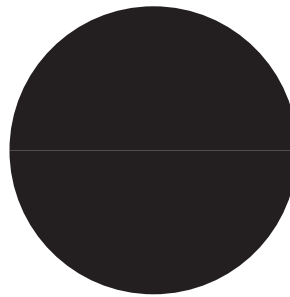

Full

Light Rail Moulding

Square

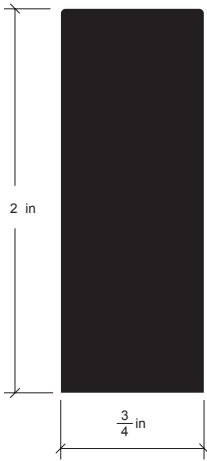

1/4 Round

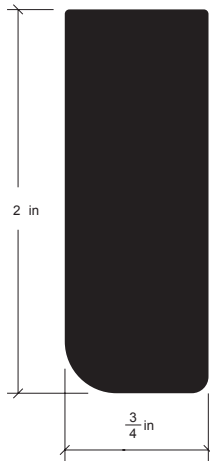

Cove

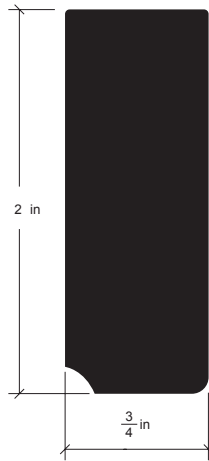

Bevel

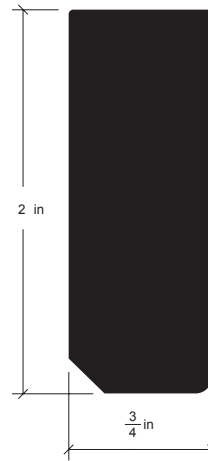

Eased

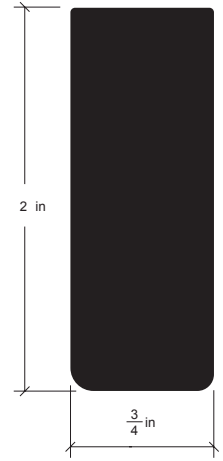

RL

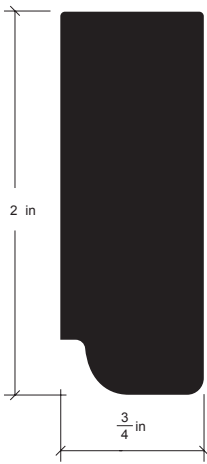

1/8 Round

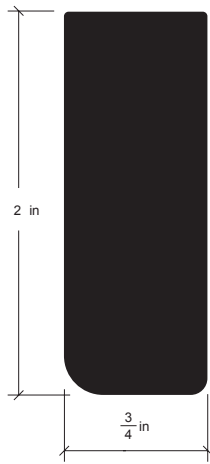

DR

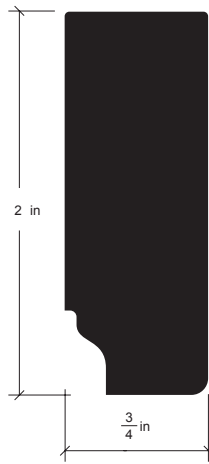

CR

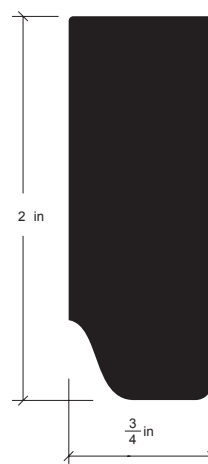

RDL

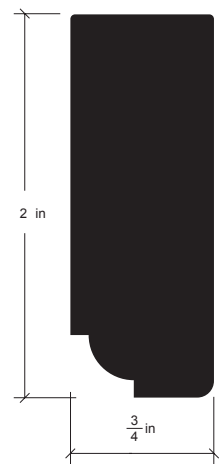

SRL

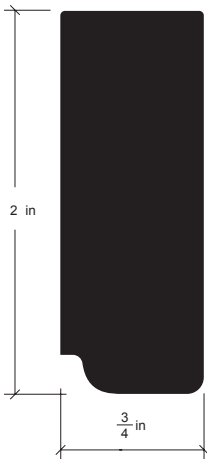

1/16 Round

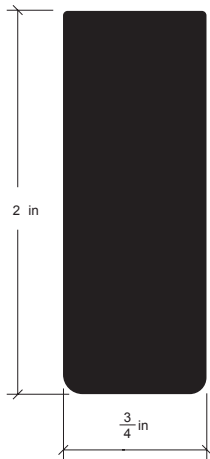

Ogee

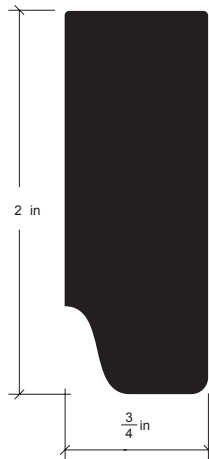

DB

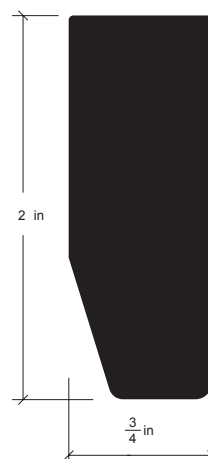

RBM S4S

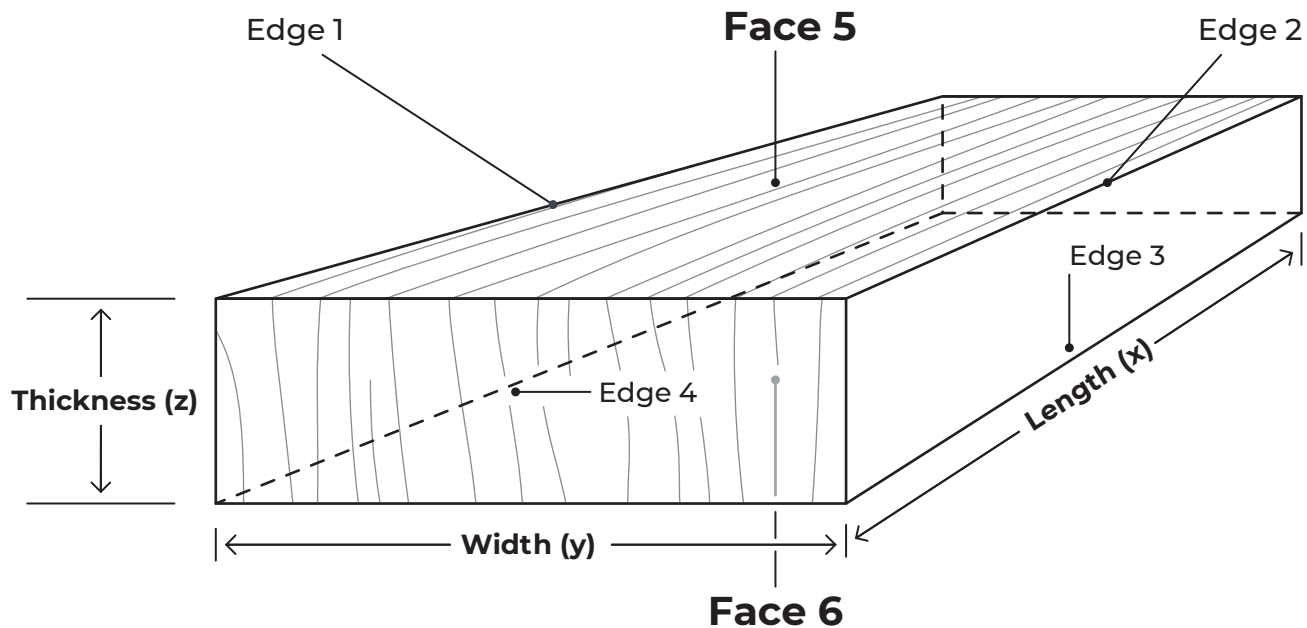

When providing us with information for surfaces please refer to this diagram. We will need to know the type of wood required, the cut desired (flat, rift, quarter cut etc.) **Length (x)**, **width (y)**, **thickness (z)**, edge profile, and linear feet required. Please note Face 5 refers to the top of the wood and Face 6 refers to the bottom.

If you need face 5 sanded please let us know. Our Normal/Standard finish Sand is 180grit. Unless otherwise specified.

Lengths:

8, 10, 12ft & Custom

Note: 10ft is the most popular, but we have or can get most requested length.

Conversion Guide

Inches Fractions	Decimal	MM	Inches Fractions	Decimal	MM	Inches Fractions	Decimal	MM	Inches Fractions	Decimal	MM
	0.00004	0.001		0.06693	1.7		0.31496	8	21/32	0.65625	16.6688
	0.00039	0.01		0.07	1.778	21/64	0.32813	8.3344		0.66929	17
	0.00079	0.02		0.07087	1.8		0.33465	8.5	43/64	0.67188	17.0656
	0.001	0.025		0.075	1.905	11/32	0.34375	8.7312	11/16	0.6875	17.4625
	0.00118	0.03	5/64	0.07813	1.9844		0.35	8.89		0.68898	17.5
	0.00157	0.04		0.07874	2		0.35433	9		0.7	17.78
	0.00197	0.05		0.08	2.032	23/64	0.35938	9.1281	45/64	0.70313	17.8594
	0.002	0.051		0.08861	2.2		0.37402	9.5		0.70866	18
	0.00236	0.06		0.09	2.286	3/8	0.375	9.525	23/32	0.71875	18.2562
	0.00276	0.07		0.09055	2.3	25/64	0.39063	9.9218		0.728835	18.1
	0.003	0.762	3/32	0.09375	2.3812		0.3937	10	47/64	0.73438	18.6531
	0.00315	0.08		0.08843	2.5		0.4	10.16		0.74803	19
	0.00354	0.09		0.1	2.54	13/32	0.40625	10.319	3/4	0.75	19.05
	0.00394	0.1		0.10236	2.6		0.41339	10.5	49/64	0.76563	19.4469
	0.004	0.1016	7/64	0.10937	2.7781	27/64	0.42188	10.716		0.76772	19.5
	0.005	0.127		0.11811	3		0.43307	11	25/32	0.78125	19.8438
	0.006	0.1524	1/8	0.125	3.175	7/16	0.4375	11.113		0.7874	20
	0.007	0.1778		0.1378	3.5		0.45	11.5	51/64	0.79688	20.2406
	0.008	0.2032	9/64	0.14036	3.5719	29/64	0.45313	11.509		0.8	20.32
	0.009	0.2286		0.15	3.18	15/32	0.46875	11.906		0.80709	20.5
	0.00984	0.25	5/32	0.15625	3.9688		0.47244	12	13/16	0.8125	20.6375
	0.01	0.254		0.15748	4	31/64	0.48438	12.303		0.82677	21
	0.01181	0.3	11/64	0.17188	4.3656		0.49213	12.5	53/64	0.82813	21.0344
1/64	0.01563	0.3969		0.175	4.445	1/2	0.5	12.7	27/23	0.84375	21.4312
	0.01575	0.4		0.17717	4.5		0.51181	13		0.84646	21.5
	0.01969	0.5	3/16	0.1875	4.7625	33/64	0.51563	13.097		0.85	21.59
	0.02	0.508		0.19685	5	17/32	0.53125	13.494	55/64	0.85938	21.8281
	0.02362	0.6		0.2	5.08		0.5315	13.5		0.86614	22
	0.025	0.635	13/64	0.20313	5.1594	35/64	0.54688	13.891	7/8	0.875	22.225
	0.02756	0.7		0.21654	5.5		0.55	13.97		0.88583	22.5
	0.0295	0.75	7/32	0.21875	5.5562		0.55118	14	57/64	0.89063	22.6219
	0.03	0.762		0.225	5.715	9/16	0.5625	14.288		0.9	22.86
1/32	0.03125	0.7938	15/64	0.23438	5.9531		0.57087	14.5		0.90551	23
	0.0315	0.8		0.23622	6	37/64	0.57813	14.684	29/32	0.90625	23.0188
	0.03543	0.9	1/4	0.25	6.35		.59055	15	59/64	0.92188	23.4156
	0.03937	1		0.25591	6.5	19/32	0.59375	15.081		0.9252	23.5
	0.04	1.016	17/64	0.26563	6.7469		0.6	15.24	15/16	0.9375	23.8125
3/64	0.04687	1.191		0.275	6.985	39/64	0.60938	15.478		0.94488	24
	0.04724	1.2		0.27599	7		0.61024	15.5	61/64	0.95313	24.13
	0.05	1.27	9/32	0.28125	7.1438	5/8	0.625	15.875		0.96457	24.5
	0.05512	1.4		0.29528	7.5		0.62992	16	31/32	0.96875	24.6062
	0.05906	1.5	19/64	0.29688	7.5406	41/64	0.64063	16.272		0.98425	25
	0.06	1.524		0.3	7.62		0.64961	16.5	63/64	0.98438	25.0031
1/16	0.0625	1.5875	5/16	0.3125	7.9375		0.65	16.51	1	1	25.4
	0.06299	1.6									



Moulding Order Form

Order #: _____

Finish Option: _____

Paint Stain Lacquer Raw Primed

Finish Color: _____

Business Name: _____

Contact Name: _____

Phone Number: _____

Email Billing Address: _____

Shipping Address: _____

Qty	Moulding Code	Moulding Length (x)	Wood Species

Qty	Moulding Code	Moulding Length (x)	Wood Species

Flat Face Baseboards/S4S

Qty	Length (x)	Height (y)	Thickness (z)	Wood Species	Edge 1	Edge 2	Edge 3	Edge 4	Back Notch
									<input type="checkbox"/>
									<input type="checkbox"/>
									<input type="checkbox"/>
									<input type="checkbox"/>
									<input type="checkbox"/>
									<input type="checkbox"/>



Moulding Order Form

Order #: _____

Finish Option: _____

Paint Stain Lacquer Raw Primed

Finish Color: _____

Business Name: _____

Contact Name: _____

Phone Number: _____

Email Billing Address: _____

Shipping Address: _____

Qty	Moulding Code	Moulding Length (x)	Wood Species

Qty	Moulding Code	Moulding Length (x)	Wood Species

Flat Face Baseboards/S4S

Qty	Length (x)	Height (y)	Thickness (z)	Wood Species	Edge 1	Edge 2	Edge 3	Edge 4	Back Notch
									<input type="checkbox"/>
									<input type="checkbox"/>
									<input type="checkbox"/>
									<input type="checkbox"/>
									<input type="checkbox"/>
									<input type="checkbox"/>
									<input type="checkbox"/>
									<input type="checkbox"/>
									<input type="checkbox"/>
									<input type="checkbox"/>

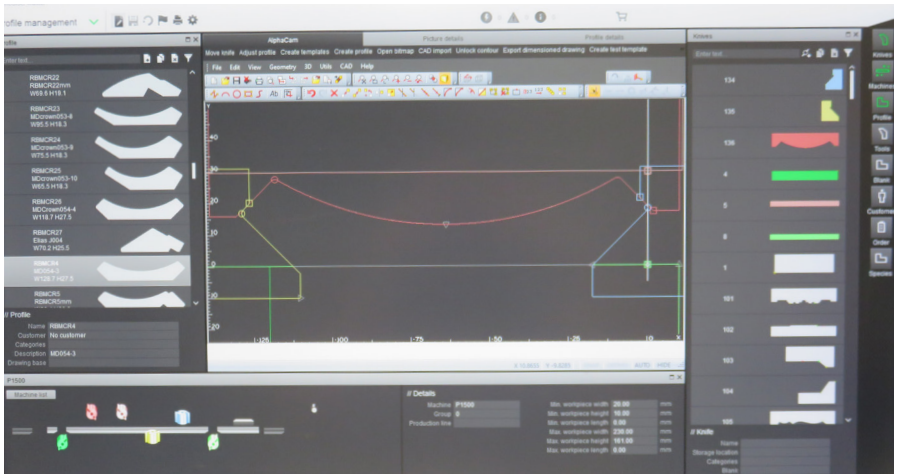
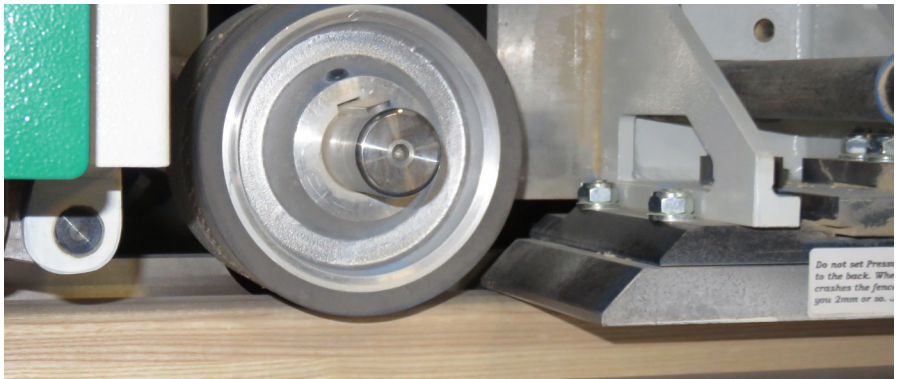

Office (204) 751 2004
 Fax (204) 515 2117
 Email orders@rbmillwork.com

Box 280
 Miami, Manitoba
 R0G 1H0

